

EXPLODED VIEW & PARTS LIST



Outdoor unit

FXU24HP230V1R32AO

FXU36HP230V1R32AO

FXU48HP230V1R32AO

FXU60HP230V1R32AO



Indoor unit

FXU24HP230V1R32AH

FXU36HP230V1R32AH

FXU48HP230V1R32AH

FXU60HP230V1R32AH

FXU24HP230V1R32AH

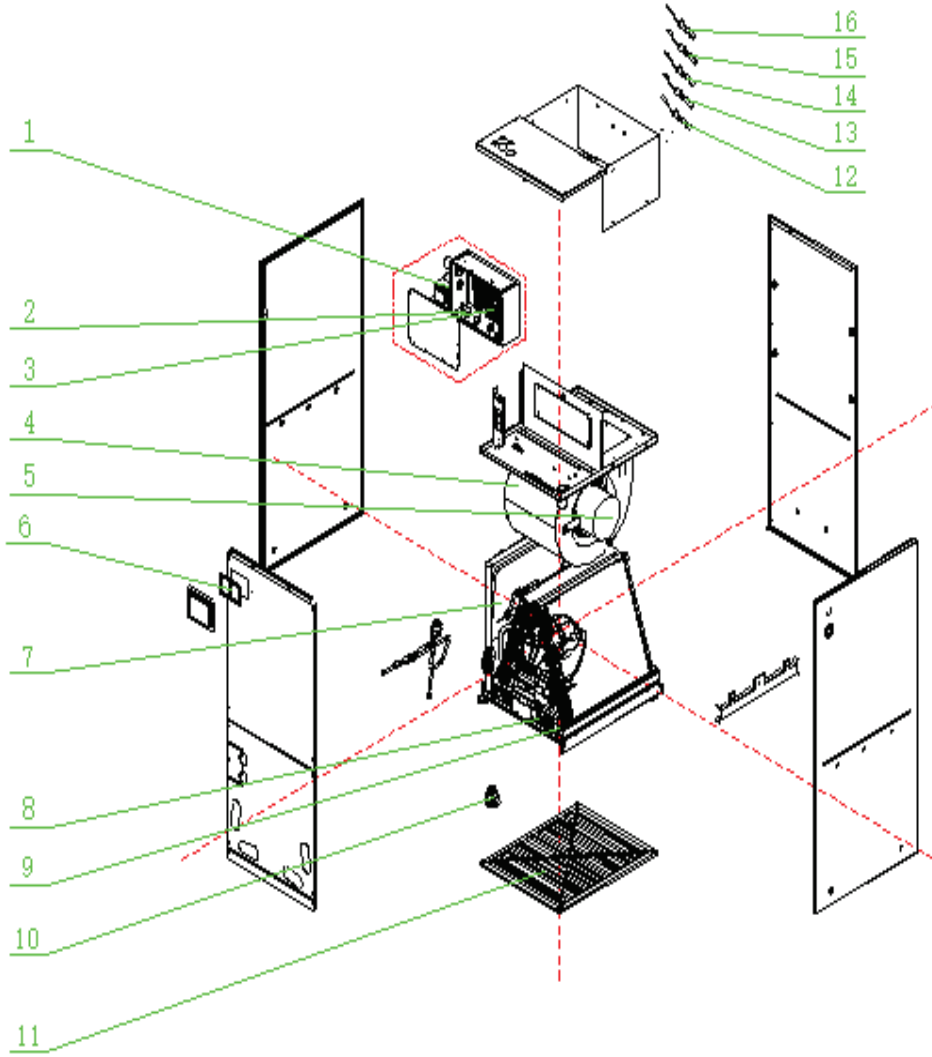

FLEXU24HP230V1R32AH

No.	Part Description	Qty	Part No.
4	Centrifugal fan assy	1	1570220101
5	Brushless DC Motor	1	15010400001401
NS	Housing	1	1570220101
NS	Water Tray	1	2690220000102
9	Water Tray	1	2690220000202
8	Choke Plug	8	76718209
NS	Joint	1	06658000008
16	Temperature Sensor	1	39000186
10	Gas Sensor	1	340024060015
3	Main Board	1	300002064036
2	Terminal Board	1	422000060207
1	Transformer	1	43110286
NS	Cable Clamp	1	71000151
NS	Jumper	1	4202021901
NS	Wire Clamp	1	71010103
12	Temperature Sensor	1	390001060085
13	Temperature Sensor	1	390001923
14	Temperature Sensor	1	390002074G
15	Temperature Sensor	1	390001060088
11	Filter Sub-Assy	1	111001060269
6	insulating board	1	75142201
NS	Packaging Foam	1	110007060322

GREE ELECTRIC APPLIANCES INC. OF ZHUHAI
GREECOMFORT.COM



[Back to main page](#)

CAT No. 06072024

FXU24HP230V1R32AO

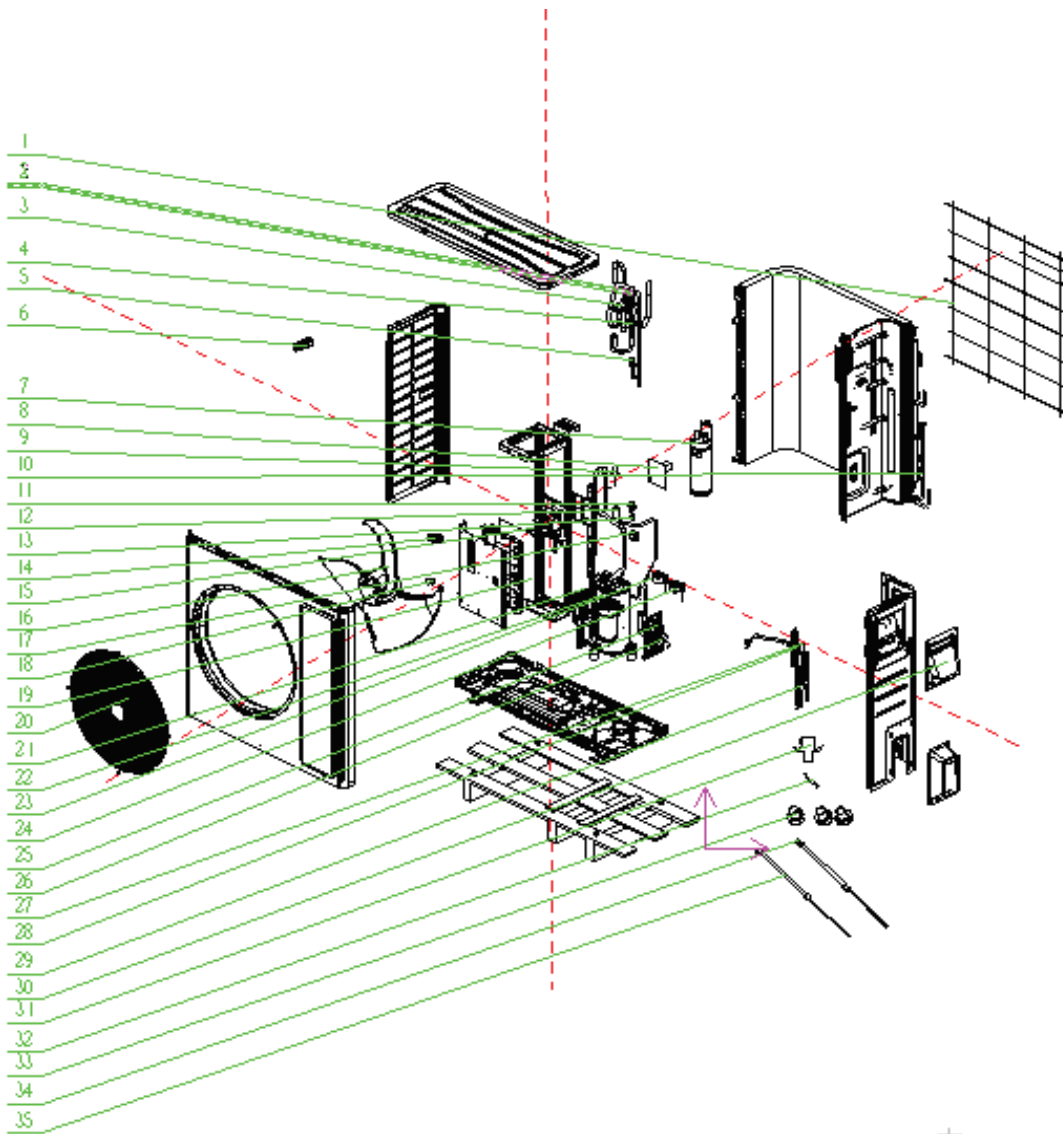

FXU24HP230V1R32AO

No.	Part Description	Qty	Part No.
NS	Chassis	1	012008060149
34	Electrical Heater (Chassis)	1	7651000417
22	Compressor and Fittings	1	009001060517ST
35	Electrical Heater	1	7651521241
7	Gas-liquid Separator	1	03502706001902
NS	Condenser Assy	1	01100206258201
NS	Left Side Plate	1	012055060508P01
30	Handle	1	2623305302
15	Brushless DC Motor	1	150104060133
21	Plate-type Heat Exchanger	1	010007060010
12	Electronic Expansion Valve	1	072009060033
NS	Strainer	1	07411124
23	Electric Expand Valve Fitting	1	07200206002322
9	Pressure Protect Switch	1	46020007
27	Electronic Expansion Valve	1	072009000018
28	One Way Valve	1	071001060011
10	Strainer	2	07411124
24	Electric Expand Valve Fitting	1	07200206002321
4	Pressure Protect Switch	1	4602000603
2	Joint	1	06652200001
5	Pressure Sensor	1	43004406002202
12	fusible plug	1	035222000004
NS	Electric Box Assy	1	100002082341
8	Filter Board	1	300020060143
19	Main Board	1	300027063867
11	Terminal Board	1	42200006001202
14	Terminal Board	1	422000060106
18	Terminal Board	1	2200006005601
32	Sensor Sub-assy	1	390002060540
NS	Jumper	1	4202021902
NS	Jumper	1	30000300000401
NS	Right Side Plate	1	012056060572P
NS	Cabinet Assy	1	00006060199
NS	Cabinet	1	012022060027P
20	Front Grill	1	016004060019
1	Rear Grill	1	01600106011401
NS	Top Cover Sub-Assy	1	000051060194
NS	Top cover	1	012049060186P01
NS	Valve Cover	1	20008706000801
NS	Packaging Foam	1	110007060866
31	Drainage Joint	1	26113009



FXU36HP230V1R32AH

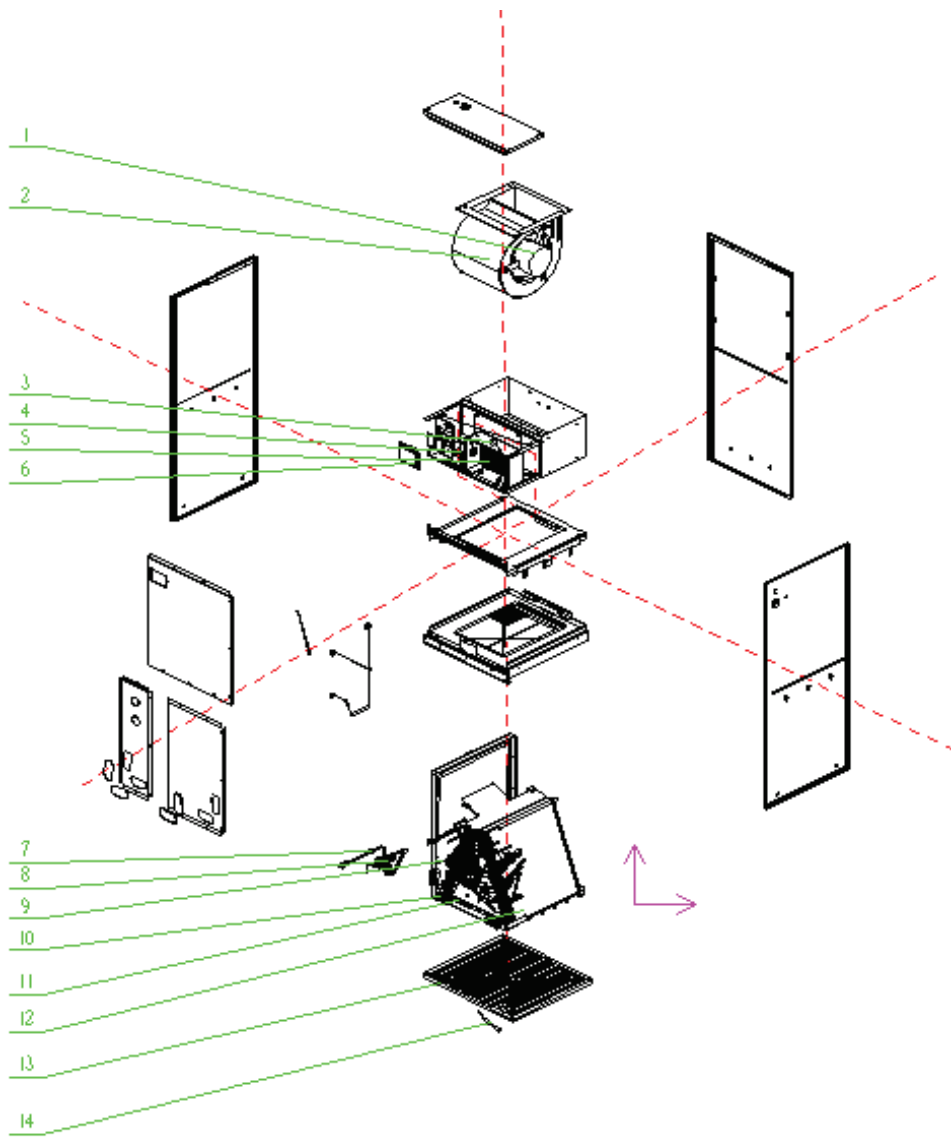

GREE ELECTRIC APPLIANCES INC. OF ZHUHAI
GREECOMFORT.COM



[Back to main page](#)

FXU36HP230V1R32AH

No.	Part Description	Qty	Part No.
NS	Side Plate	1	012010060972
NS	Fan Fixing Plate Assy	2	01842232
NS	Centrifugal fan assy	1	000052060415
1	Centrifugal Fan Housing	1	1570220201
2	Brushless DC Motor	1	15010400001401
9	Water Tray	1	2690220402
10	Choke Plug	4	76718209
NS	Evaporator Sub-Assy	1	01000106029101
7	Strainer	2	0721200102
NS	Evaporator Sub-Assy	1	01000106029201
NS	Water Tray	1	2690220502
NS	Choke Plug	4	76718209
NS	Joint	1	06658000008
NS	Temperature Sensor	1	39000186
NS	Main Board	1	300002064036
5	Terminal Board	1	42200006005601
4	Transformer	1	43110286
NS	Cable Clamp	1	71000151
NS	Jumper	1	4202021902
NS	Wire Clamp	1	71010103
14	Temperature Sensor	1	390001060085
NS	Temperature Sensor	1	390001923
NS	Temperature Sensor	1	390002074G
NS	Temperature Sensor	1	390001060088
NS	Gas Sensor	1	340024060015
NS	insulating board	1	75142201
13	Filter Sub-Assy	1	111001060160
NS	Packaging Foam	1	110007060322

GREE ELECTRIC APPLIANCES INC. OF ZHUHAI
GREECOMFORT.COM

CAT No. 06122024



[Back to main page](#)

FXU36HP230V1R32AO

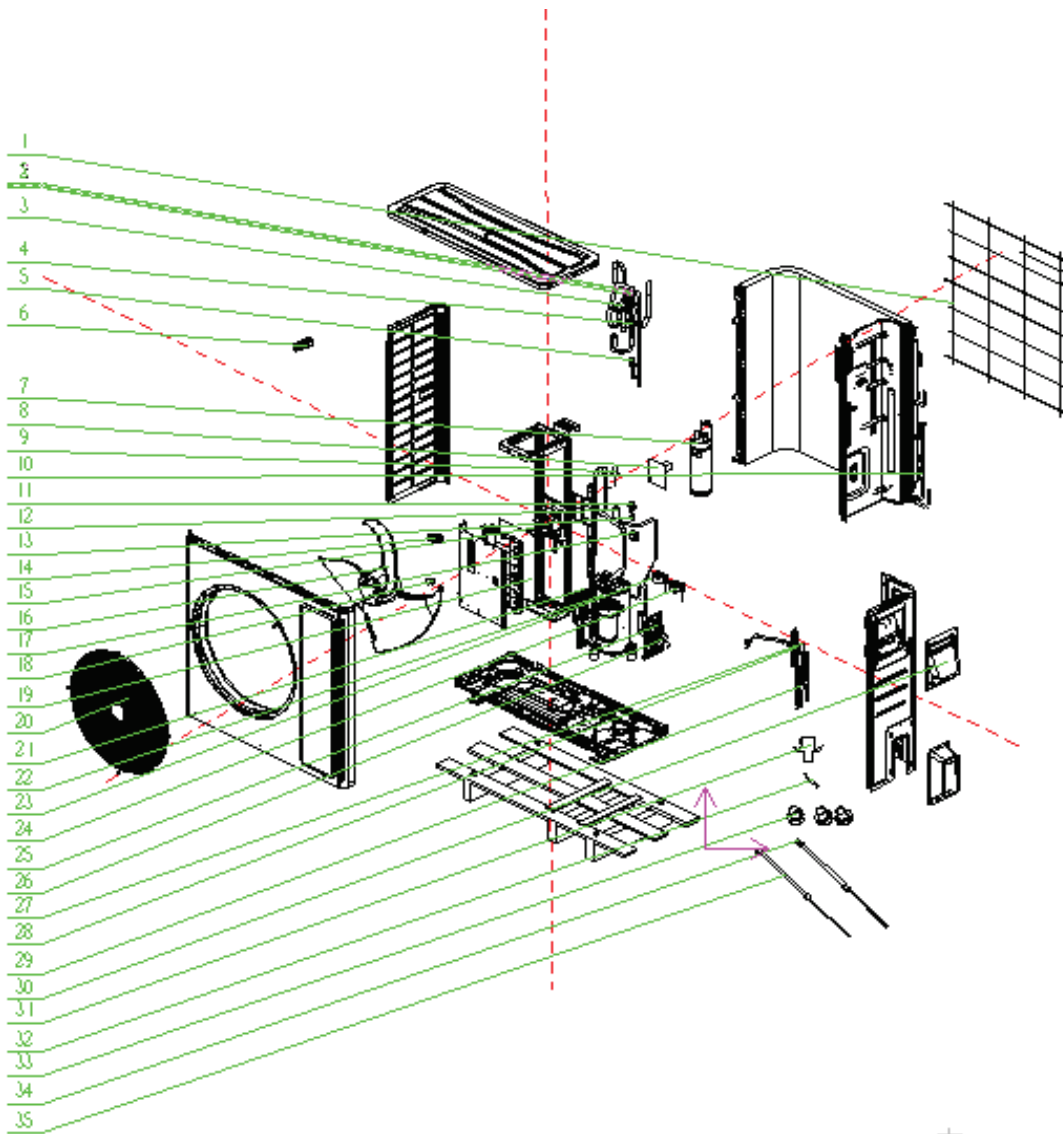

FXU36HP230V1R32AO

No.	Part Description	Qty	Part No.
NS	Chassis	1	012008060149
34	Electrical Heater (Chassis)	1	7651000417
22	Compressor and Fittings	1	009001060517ST
35	Electrical Heater	1	7651521241
7	Gas-liquid Separator	1	03502706001902
NS	Condenser Assy	1	01100206258201
NS	Strainer	1	0721212101
NS	Left Side Plate	1	012055060508P01
30	Handle	1	2623305302
16	Axial Flow Fan	1	103002060028
15	Brushless DC Motor	1	150104060133
21	Plate-type Heat Exchanger	1	010007060010
NS	Electronic Expansion Valve	1	072009060033
NS	Strainer	1	07411124
NS	Electric Expand Valve Fitting	1	07200206002322
4	Pressure Protect Switch	1	46020007
NS	Electronic Expansion Valve	1	072009000018
28	One Way Valve	1	071001060011
NS	Strainer	2	07411124
NS	Electric Expand Valve Fitting	1	07200206002321
NS	Pressure Protect Switch	1	4602000603
NS	Joint	1	06652200001
NS	Pressure Sensor	1	43004406002202
NS	fusible plug	1	035222000004
NS	Electric Box Assy	1	100002082341
NS	Filter Board	1	300020060143
NS	Main Board	1	300027063867
NS	Terminal Board	1	42200006001202
NS	Terminal Board	1	422000060106
NS	Terminal Board	1	42200006005601
32	Sensor Sub-assy	1	390002060540
NS	Jumper	1	4202021903
NS	Jumper	1	30000300000401
NS	Right Side Plate	1	012056060572P
NS	Cabinet Assy	1	000006060199
NS	Cabinet	1	012022060027P
20	Front Grill	1	016004060019
1	Rear Grill	1	01600106011401
NS	Top Cover Sub-Assy	1	000051060194
NS	Top cover	1	012049060186P01
NS	Valve Cover	1	20008706000801
NS	Packaging Foam	1	110007060866
NS	Drainage Joint	1	26113009



FXU48HP230V1R32AH

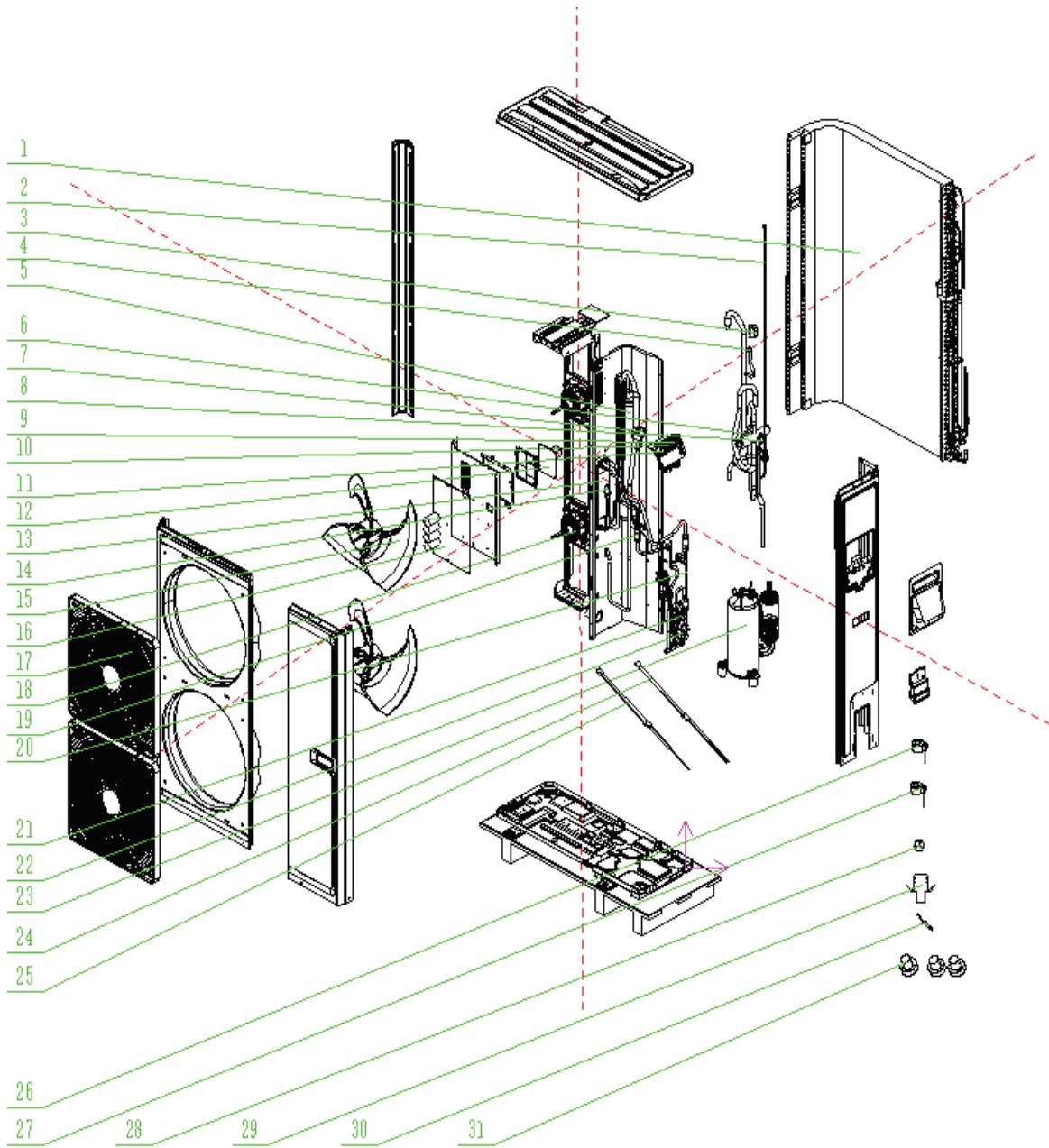

GREE ELECTRIC APPLIANCES INC. OF ZHUHAI
GREECOMFORT.COM



[Back to main page](#)

FXU48HP230V1R32AH

No.	Part Description	Qty	Part No.
NS	Air Scroll	1	012277060111
NS	Fan Fixing Plate Assy	2	01842232
NS	Joint	1	06658000008
NS	Top Cover Sub-Assy	1	000051060202
NS	Top Cover Sub-Assy	1	000051060203
NS	Centrifugal fan assy	1	000052060413
2	Centrifugal Fan Housing	1	1570220301
1	Brushless DC Motor	1	15010400001301
9	Water Tray	1	2690220602
10	Choke Plug	4	76718209
NS	Strainer	2	0721200102
NS	Strainer	1	0721200102
12	Evaporator Sub-Assy	2	010001060326
11	Water Tray	1	2690220502
10	Choke Plug	4	76718209
NS	Joint	1	06658000008
NS	Temperature Sensor	1	39000186
NS	Gas Sensor	1	340024060015
NS	Main Board	1	300002064036
5	Terminal Board	1	42200006005601
4	Transformer	1	43110286
NS	Cable Clamp	1	71000151
NS	Jumper	1	4202021903
NS	Wire Clamp	1	71010103
14	Temperature Sensor	1	390001060085
15	Temperature Sensor	1	390001923
NS	Temperature Sensor	1	390002074G
NS	Temperature Sensor	1	390001060088
NS	insulating board	1	75142201
13	Filter Sub-Assy	1	111001060188
NS	Packaging Foam	1	110007060360

GREE ELECTRIC APPLIANCES INC. OF ZHUHAI
GREECOMFORT.COM



[Back to main page](#)

CAT No. 06122024

FXU48HP230V1R32AO

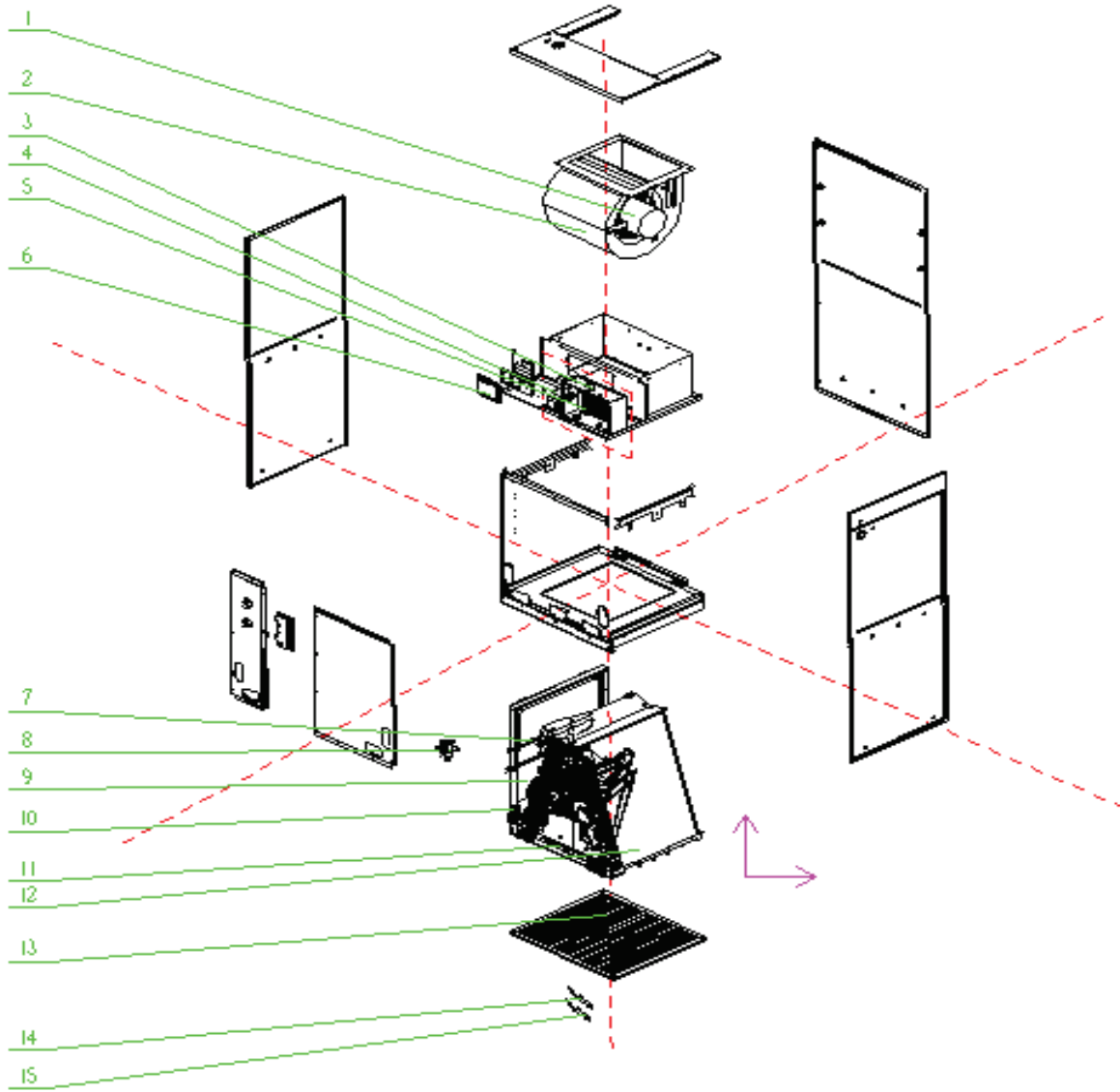

GREE ELECTRIC APPLIANCES INC. OF ZHUHAI
GREECOMFORT.COM



[Back to main page](#)

FXU48HP230V1R32AO

No.	Part Description	Qty	Part No.
NS	Chassis Sub-assy	1	209020060053
NS	Chassis Sub-assy	1	017000061114P
23	Compressor and Fittings	1	009001060980
24	Electrical Heater(Compressor)	1	765152128
1	Condenser Assy	1	011002062380
NS	Brushless DC Motor	1	150104060074
18	Brushless DC Motor	1	15010406007401
NS	Motor Support Sub-Assy	1	017012060451
5	Gas-liquid Separator	1	035027060022
8	Pressure Protect Switch	1	46020007
NS	Fixed Block of Tube	1	708400113
6	4-Way Valve	1	43000338
4	Joint	1	'6652200001
7	Pressure Protect Switch	1	4602000603
NS	Fixed Block of Tube	2	70843025
28	4 Way Valve Coil	1	07201006000604
3	fusible plug	1	035222000004
19	Strainer	2	035021060018
20	One Way Valve	1	071001060011
14	Electronic Expansion Valve	1	43005017
NS	Fixed Block of Tube	2	708400113
26	Electric Expand Valve Fitting	1	4304413297
13	Plate-type Heat Exchanger	1	00904100004
19	Strainer	1	035021060018
NS	Electronic Expansion Valve	1	072009060011
27	Electric Expand Valve Fitting	1	07200206002329
NS	Electric Box Assy	1	100002082342
12	Filter Board	1	300020060144
16	Main Board	1	300027063855
9	Terminal Board	1	42200006001202
10	Terminal Board	1	422000060106
11	Terminal Board	1	42200006005601
30	Sensor Sub-assy	1	390002060557
NS	Jumper	1	30000300000405
NS	Left Side Plate	1	01205506043501P01
NS	Cabinet Assy	1	000006060262
NS	Cabinet	1	01202206002201P01
17	Front Grill	2	01600406000201
NS	Right Side Plate Assy	1	000081060413
NS	Top Cover Sub-Assy	1	000051060270
NS	Top cover	1	0120490600098P01
NS	Valve Cover	1	20008706000801
NS	Packaging Foam	1	110007060653
29	Drainage Joint	1	26113009



FXU60HP230V1R32AH

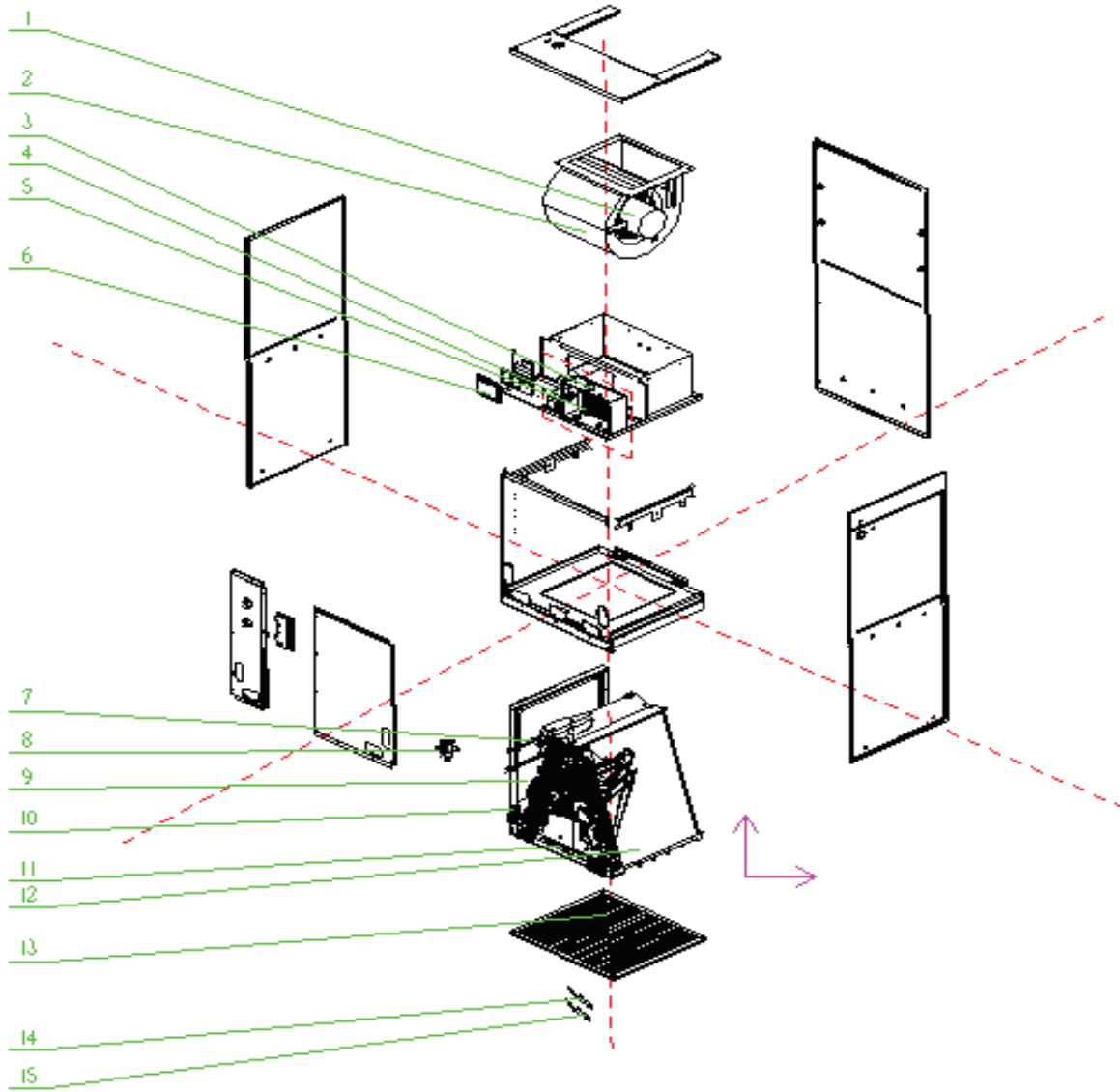

GREE ELECTRIC APPLIANCES INC. OF ZHUHAI
GREECOMFORT.COM



[Back to main page](#)

FXU60HP230V1R32AH

No.	Part Description	Qty	Part No.
NS	Air Scroll	1	012277060111
NS	Fan Fixing Plate	2	01842232
NS	Joint	1	06658000008
NS	Top Cover Sub-Assy	1	000051060202
NS	Top Cover Sub-Assy	1	000051060203
NS	Centrifugal fan assy	1	000052060413
2	Centrifugal Fan Housing	1	1570220301
1	Brushless DC Motor	1	15010400001301
9	Water Tray	1	2690220602
10	Choke Plug	4	76718209
7	Strainer	2	0721200102
7	Strainer	1	0721200102
12	Evaporator Sub-Assy	2	010001060326
11	Water Tray	1	2690220502
10	Choke Plug	4	76718209
NS	Joint	1	06658000008
15	Temperature Sensor	1	39000186
NS	Gas Sensor	1	340024060015
NS	Main Board	1	300002064036
3	Terminal Board	1	42200006005601
4	Transformer	1	43110286
NS	Cable Clamp	1	71000151
NS	Wire Clamp	1	71010103
14	Temperature Sensor	1	390001060085
NS	Temperature Sensor	1	390001923
NS	Temperature Sensor	1	390002074G
NS	Temperature Sensor	1	390001060088
NS	insulating board	1	75142201
13	Filter Sub-Assy	1	111001060188
NS	Packaging Foam	1	110007060360

GREE ELECTRIC APPLIANCES INC. OF ZHUHAI
GREECOMFORT.COM



[Back to main page](#)

CAT No. 06122024

FXU60HP230V1R32AO

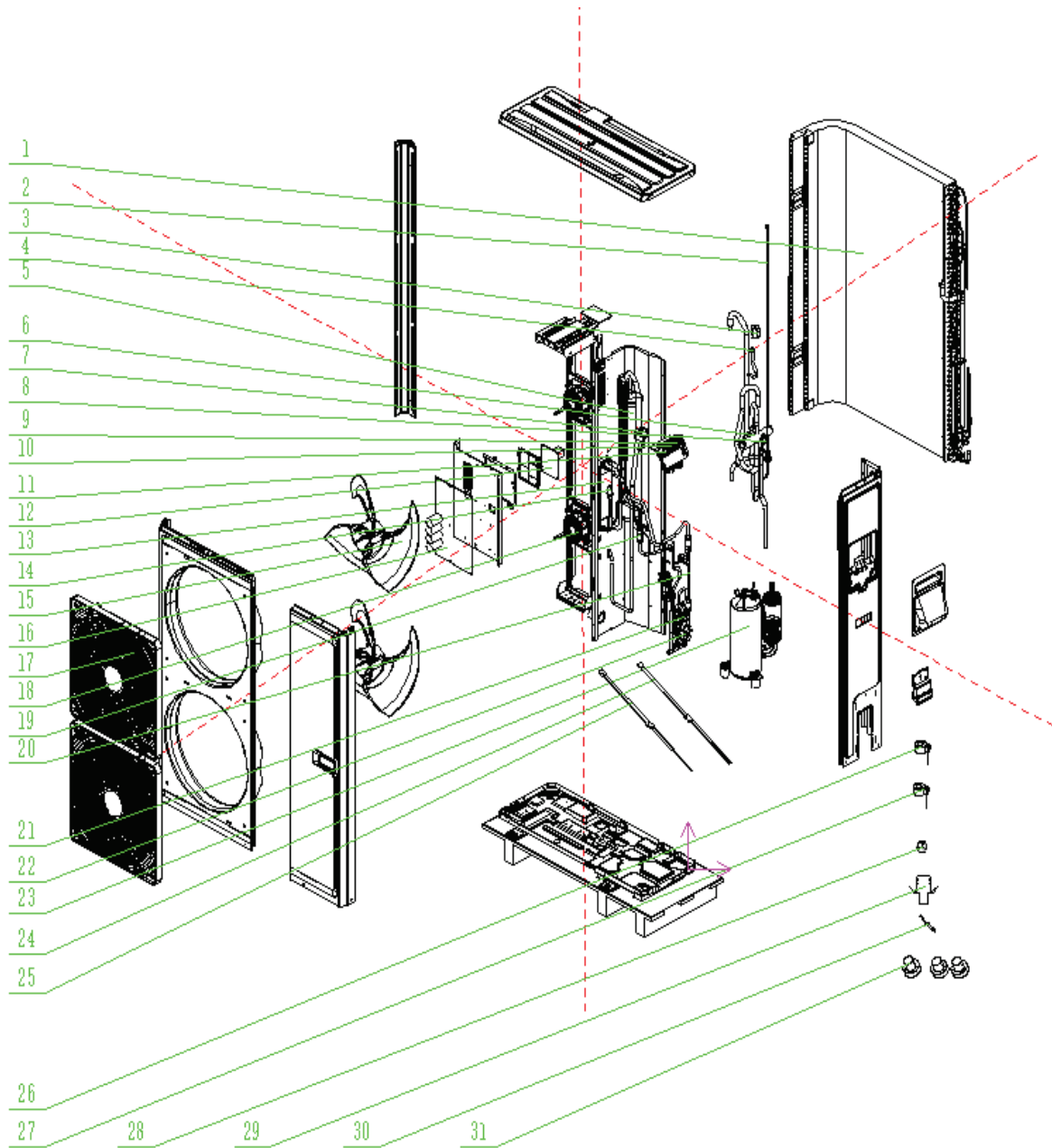

GREE ELECTRIC APPLIANCES INC. OF ZHUHAI
GREECOMFORT.COM



[Back to main page](#)

FXU60HP230V1R32AO

No.	Part Description	Qty	Part No.
NS	Chassis Sub-assy	1	209020060053
NS	Chassis Sub-assy	1	017000061114P
23	Compressor and Fittings	1	009001060980
24	Electrical Heater(Compressor)	1	765152128
1	Condenser Assy	1	011002062380
NS	Brushless DC Motor	1	150104060074
18	Brushless DC Motor	1	15010406007401
NS	Motor Support Sub-Assy	1	017012060451
5	Gas-liquid Separator	1	035027060022
8	Pressure Protect Switch	1	46020007
NS	Fixed Block of Tube	1	708400113
6	4-Way Valve	1	43000338
NS	Joint	1	06652200001
7	Pressure Protect Switch	1	4602000603
NS	Fixed Block of Tube	2	70843025
28	4 Way Valve Coil	1	07201006000604
3	fusible plug	1	035222000004
19	Strainer	2	035021060018
20	One Way Valve	1	071001060011
14	Electronic Expansion Valve	1	43005017
NS	Fixed Block of Tube	2	708400113
26	Electric Expand Valve Fitting	1	4304413297
13	Plate-type Heat Exchanger	1	00904100004
19	Strainer	1	035021060018
NS	Electronic Expansion Valve	1	072009060011
27	Electric Expand Valve Fitting	1	07200206002329
NS	Electric Box Assy	1	100002082342
12	Filter Board	1	300020060144
16	Main Board	1	300027063855
9	Terminal Board	1	42200006001202
10	Terminal Board	1	422000060106
11	Terminal Board	1	42200006005601
30	Sensor Sub-assy	1	390002060557
NS	Jumper	1	30000300000405
NS	Left Side Plate	1	01205506043501P01
NS	Cabinet Assy	1	000006060262
NS	Cabinet	1	01202206002201P01
17	Front Grill	2	01600406000201
NS	Right Side Plate Assy	1	000081060413
NS	Top Cover Sub-Assy	1	000051060270
NS	Top cover	1	012049060098P01
NS	Valve Cover	1	20008706000801
NS	Packaging Foam	1	110007060653
29	Drainage Joint	1	26113009

