



Service Manual

LIVS36HP230V1CH
LIVV30HP230V1AH
LIVV36HP230V1AH
VIR30HP230V1BH
VIR36HP230V1BH
VIRU30HP230V1AH
VIRU36HP230V1AH
VIR36HP230V1CH

LIVS36HP230V1CO
LIVV30HP230V1AO
LIVV36HP230V1O
VIR30HP230V1BO
VIR36HP230V1BO
VIRU30HP230V1AO
VIRU36HP230V1AO
VIR36HP230V1CO

GREE ELECTRIC APPLIANCES, INC. OF ZHUHAI

Table of Contents

Part I : Technical Information	1
1. Summary	1
2. Specifications	3
2.1 Specification Sheet.....	3
2.2 Capacity Variation Ratio According to Temperature	15
2.3 Noise Curve	16
2.4 Cooling and Heating Data Sheet in Rated Frequency.....	16
3. Outline Dimension Diagram	17
3.1 Indoor Unit.....	17
3.2 Outdoor Unit.....	17
4. Refrigerant System Diagram	19
5. Electrical Part	22
5.1 Wiring Diagram	22
5.2 PCB Printed Diagram	26
6. Function and Control	30
6.1 Remote Controller Introduction of YAN1F6F(WiFi).....	30
6.2 Remote Controller Introduction of YV1FB9F(WiFi).....	35
6.3 GREE+ App Operation Manual	39
6.4 Ewpe Smart App Operation Manual.....	40
6.5 Brief Description of Modes and Functions	41
Part II : Installation and Maintenance	44
7. Notes for Installation and Maintenance	44
8. Installation	47
8.1 Installation Dimension Diagram.....	47
8.2 Installation Parts-checking	49
8.3 Selection of Installation Location.....	49

Remote Controller:

YAN1F6F(WiFi)



Model List:

No	Model	Product code	Indoor model	Indoor product code	Outdoor model	Outdoor product code	Remote Controller
							YAN1F6F(WiFi)
6	LIVV36HP230V1A	CB432023000	LIVV36HP230V1AH	CB432N23000	LIVV36HP230V1AO	CB432W23000	
8	VIR36HP230V1B	CB433000402	VIR36HP230V1BH	CB433N00402	VIR36HP230V1BO	CB171W10800	YAN1F6FWiFi)
12	VIRU36HP230V1A	CB432010100	VIRU36HP230V1AH	CB432N10100	VIRU36HP230V1AO	CB432W10100	YAN1F6F(WiFi)
13	VIR30HP230V1BH	CB433000202	VIR30HP230V1BH	CB433N00202	VIR30HP230V1BO	CB171W10600	
15	VIRU30HP230V1A	CB432010000	VIRU30HP230V1AH	CB432N10000	VIRU30HP230V1AO	CB432W10000	
						CB432W22200	
17	LIVV30HP230V1A	CB432022100	LIVV30HP230V1AH	CB432N22100	LIVV30HP230V1AO	CB432W22100	
	VIR36HP230V1C	CB432008101	VIR36HP230V1CH	CB432N08101	VIR36HP230V1CO	CB432W08100	
22	LIVS36HP230V1C	CB432020300	LIVS36HP230V1CH	CB432N20300	LIVS36HP230V1CO	CB432W20300	

Outdoor Unit	Model of Outdoor Unit		VIR30HP230V1BO	
	Outdoor Unit Product Code		CB171W10600	
	Compressor Manufacturer/Trademark		ZHUHAI LANDA COMPRESSOR CO.LTD.	
	Compressor Model		QXAS-D23zX090	
	Compressor Oil		RB68EP	
	Compressor Type		Rotary	
	Compressor Locked Rotor Amp (L.R.A)		40	
	Compressor RLA	A		13.45
	Compressor Power Input	W		2450
	Overload Protector			1NT11L-6233
	Throttling Method			Electron expansion valve+Capillary
	Operation temp	°F		61~86
	Ambient temp (cooling)	°F		0~115
	Ambient temp (heating)	°F		-4~75
	Condenser Form			Aluminum Fin-copper Tube
	Pipe Diameter	inch		Φ5/16
	Rows-fin Gap	inch		2-1/16
	Coil Length (LXDXW)	inch		37 1/2X1 1/2X29 7/16
	Fan Motor Speed	rpm		795
	Output of Fan Motor	W		120
	Fan Motor RLA	A		0.45
	Fan Motor Capacitor	μF		/
	Air Flow Volume of Outdoor Unit	CFM		2354
	Fan Type			Axial-flow
	Fan Diameter	inch		Φ21 21/32
	Defrosting Method			Automatic Defrosting
	Climate Type			T1
	Isolation			I
	Moisture Protection			IPX4
	Design Pressure(High)	PSIG		550
	Design Pressure(Low)	PSIG		240
	Sound Pressure Level (H/M/L)	dB (A)		62/-/-
	Sound Power Level (H/M/L)	dB (A)		72/-/-
Dimension (WXHXD)	inch		39 1/2X31 7/64X16 13/16	
Dimension of Carton Box (LXWXH)	inch		42 1/2X19X33	
Dimension of Package (LXWXH)	inch		42 21/32X19 13/64X33 21/32	
Net Weight	lb		154.3	
Gross Weight	lb		165.4	
Refrigerant			R410A	
Refrigerant Charge	oz		84.66	
Connection Pipe	Length	ft	24.6	
	Gas Additional Charge	oz/ft	0.5	
	Outer Diameter Liquid Pipe	inch	1/4	
	Outer Diameter Gas Pipe	inch	5/8	
	Max Distance Height	ft	32 3/16	
	Max Distance Length	ft	98 27/64	
	Note:The connection pipe applies metric diameter.			

The above data is subject to change without notice; please refer to the nameplate of the unit.

Outdoor Unit	Model of Outdoor Unit		VIR36HP230V1BO(LCLH)
	Outdoor Unit Product Code		CB171W10800
	Compressor Manufacturer/Trademark		MITSUBISHI ELECTRIC (GUANGZHOU)COMPRESSOR CO. LTD
	Compressor Model		TNB306FPGMC
	Compressor Oil		FV50S
	Compressor Type		Rotary
	Compressor Locked Rotor Amp (L.R.A)		67.00
	Compressor RLA	A	17.5
	Compressor Power Input	W	3010
	Overload Protector		CS01F272H01
	Throttling Method		Electron expansion valve
	Operation temp	°F	61~86
	Ambient temp (cooling)	°F	0~109
	Ambient temp (heating)	°F	-4~75
	Condenser Form		Aluminum Fin-copper Tube
	Pipe Diameter	inch	Φ5/16
	Rows-fin Gap	inch	2-1/16
	Coil Length (LXDXW)	inch	37X1 3/4X30
	Fan Motor Speed	rpm	890
	Output of Fan Motor	W	170
	Fan Motor RLA	A	0.73
	Fan Motor Capacitor	μF	/
	Air Flow Volume of Outdoor Unit	CFM	2589
	Fan Type		Axial-flow
	Fan Diameter	inch	Φ21 21/32
	Defrosting Method		Automatic Defrosting
	Climate Type		T1
	Isolation		I
	Moisture Protection		IPX4
	Design Pressure(High)	PSIG	550
	Design Pressure(Low)	PSIG	240
	Sound Pressure Level (H/M/L)	dB (A)	65/-/-
	Sound Power Level (H/M/L)	dB (A)	75/-/-
Dimension (WXHXD)	inch	39 1/2X31 7/64X16 13/16	
Dimension of Carton Box (LXWXH)	inch	42 1/2X19X33	
Dimension of Package (LXWXH)	inch	42 21/32X19 13/64X33 21/32	
Net Weight	lb	161.0	
Gross Weight	lb	172.0	
Refrigerant		R410A	
Refrigerant Charge	oz	91.71	
Connection Pipe	Length	ft	24.6
	Gas Additional Charge	oz/ft	0.5
	Outer Diameter Liquid Pipe	inch	1/4
	Outer Diameter Gas Pipe	inch	5/8
	Max Distance Height	ft	32 3/16
	Max Distance Length	ft	98 27/64
	Note:The connection pipe applies metric diameter.		

The above data is subject to change without notice; please refer to the nameplate of the unit.

Model			VIRU36HP230V1A		
Product Code			CB432010100		
Power Supply	Rated Voltage	V~	208/230		
	Rated Frequency	Hz	60		
	Phases		1		
Power Supply Mode			Outdoor		
Cooling Capacity(Min~Max)		Btu/h	33000(8800~40900)		
Heating Capacity(Min~Max)		Btu/h	34600(16700~49400)		
Cooling Power Input(Min~Max)		W	3220(500~4100)		
Heating Power Input(Min~Max)		W	3100(1000~7000)		
Cooling Power Current		A	14.7		
Heating Power Current		A	14.2		
Rated Input		W	7000		
Rated Current		A	19		
Rated Heating Current		A	30		
Air Flow Volume(SH/H/M/L)		CFM	824/706/589/441		
Dehumidifying Volume		Pint/h	7.4		
EER		(Btu/h)/W	10.25		
COP		(Btu/h)/W	11.16		
SEER			23		
HSPF			10.5		
Application Area		yd ²	55.01-83.72		
Indoor Unit	Model of indoor unit		VIRU36HP230V1AH		
	Indoor Unit Product Code		CB432N10100		
	Fan Type		Cross-flow		
	Diameter Length(DXL)		inch	Φ4 1/4X20 9/16	
	Fan Motor Cooling Speed (SH/H/M/L)		r/min	1550/1300/1150/850	
	Fan Motor Heating Speed (SH/H/M/L)		r/min	1500/1300/1150/1000	
	Output of Fan Motor		W	70	
	Fan Motor RLA		A	0.4	
	Fan Motor Capacitor		μF	/	
	Evaporator Form			Aluminum Fin-copper Tube	Aluminum Fin-copper Tube
	Pipe Diameter		inch	Φ9/32	
	Row-fin Gap		inch	2-1/16	
	Coil Length (LXDXW)		inch	42 9/32X1X15	
	Swing Motor Model			MP24BA	
	Output of Swing Motor		W	2	
	Fuse		A	5	
	Sound Pressure Level (SH/H/M/L)		dB (A)	54/49/44/37	
	Sound Power Level (SH/H/M/L)		dB (A)	64/59/54/47	
	Dimension (WXHDXD)		inch	53 9/64X12 53/64X9 61/64	
	Dimension of Carton Box (LXWXH)		inch	56 39/64X16 29/64X13 55/64	
	Dimension of Package (LXWXH)		inch	56 47/64X16 37/64X14 7/16	
	Net Weight		lb	41.9	
Gross Weight		lb	51.8		

Outdoor Unit	Model of Outdoor Unit		VIRU36HP230V1AO	VIRU30HP230V1AO
	Outdoor Unit Product Code		CB432W10100	CB432W10000
	Compressor Manufacturer/Trademark		ZHUHAI LANDA COMPRESSOR CO., LTD	ZHUHAI LANDA COMPRESSOR CO., LTD
	Compressor Model		QXAW-F518zX440C	QXFW-D318ZX035
	Compressor Oil		FV50S or equivalent	FW68DA or equivalent
	Compressor Type		Rotary	Rotary
	Compressor Locked Rotor Amp (L.R.A)		36	30
	Compressor RLA	A	24	23
	Compressor Power Input	W	5830±3%	3350±3%
	Overload Protector		/	/
	Throttling Method		Electron expansion valve	Electron expansion valve
	Operation temp	°F	61~86	61~86
	Ambient temp (cooling)	°F	0~109	0~109
	Ambient temp (heating)	°F	-31~75	-31~75
	Condenser Form		Aluminum Fin-copper Tube	Aluminum Fin-copper Tube
	Pipe Diameter	inch	Φ5/16	Φ5/16
	Rows-fin Gap	inch	2-1/16	2-1/16
	Coil Length (LXDXW)	inch	41 37/64X1 1/2×38 13/64	41 37/64X1 1/2×38 13/64
	Fan Motor Speed	rpm	940	850
	Output of Fan Motor	W	170	170
	Fan Motor RLA	A	0.73	0.73
	Fan Motor Capacitor	μF	/	0
	Air Flow Volume of Outdoor Unit	CFM	3119	5300
	Fan Type		Axial-flow	Axial-flow
	Fan Diameter	inch	Φ21 21/32	Φ21 21/32
	Defrosting Method		Automatic Defrosting	Automatic Defrosting
	Climate Type		T1	T1
	Isolation		I	I
	Moisture Protection		IPX4	IPX4
	Design Pressure(High)	PSIG	550	550
	Design Pressure(Low)	PSIG	240	240
	Sound Pressure Level (H/M/L)	dB (A)	63/-/-	61/-/-
	Sound Power Level (H/M/L)	dB (A)	73/-/-	73/-/-
Dimension (WXHXD)	inch	43 37/64X43 1/2X16 9/64	43 37/64X43 1/2X16 9/64	
Dimension of Carton Box (LXWXH)	inch	45 1/2X18 57/64X45 39/64	45 1/2X18 57/64X45 39/64	
Dimension of Package (LXWXH)	inch	45 39/64X19 X44 9/32	45 39/64X19 X44 9/32	
Net Weight	lb	253.53	229.3	
Gross Weight	lb	271.17	240.3	
Refrigerant		R410A	R410A	
Refrigerant Charge	oz	123.5	123.5	
Connection Pipe	Length	ft	24.6	24.6
	Gas Additional Charge	oz/ft	0.3	0.3
	Outer Diameter Liquid Pipe	inch	1/4	1/4
	Outer Diameter Gas Pipe	inch	5/8	5/8
	Max Distance Height	ft	98.4	98.4
	Max Distance Length	ft	164	164
	Note:The connection pipe applies metric diameter.			

The above data is subject to change without notice; please refer to the nameplate of the unit.

Outdoor Unit	Model of Outdoor Unit		VIR36HP230V1CO	LIVS36HP230V1CO
	Outdoor Unit Product Code		CB432W08100	CB432W20300
	Compressor Manufacturer/Trademark		ZHUHAI LANDA COMPRESSORCO., LTD.	ZHUHAI LANDA COMPRESSORCO., LTD.
	Compressor Model		QXAS-D32zX090A	QXAS-D32zX090A
	Compressor Oil		FV50S	FV50S
	Compressor Type		Rotary	Rotary
	Compressor Locked Rotor Amp (L.R.A)		67	67
	Compressor RLA	A	17.5	17.5
	Compressor Power Input	W	4150	4150
	Overload Protector		1NT11L-6233/HPC 115/95/KSD 115oC	1NT11L-6233/HPC 115/95/KSD 115oC
	Throttling Method		Electron expansion valve	Electron expansion valve
	Operation temp	°F	61~86	61~86
	Ambient temp (cooling)	°F	0~109	0~109
	Ambient temp (heating)	°F	-4~75	-4~75
	Condenser Form		Aluminum Fin-copper Tube	Aluminum Fin-copper Tube
	Pipe Diameter	inch	Φ5/16	Φ5/16
	Rows-fin Gap	inch	2-1/16	2-1/16
	Coil Length (LXD _X W)	inch	37X1 3/4X30	37X1 3/4X30
	Fan Motor Speed	rpm	890	890
	Output of Fan Motor	W	170	170
	Fan Motor RLA	A	0.73	0.73
	Fan Motor Capacitor	μF	/	/
	Air Flow Volume of Outdoor Unit	CFM	2589	2589
	Fan Type		Axial-flow	Axial-flow
	Fan Diameter	inch	Φ21 21/32	Φ21 21/32
	Defrosting Method		Automatic Defrosting	Automatic Defrosting
	Climate Type		T1	T1
	Isolation		I	I
	Moisture Protection		IPX4	IPX4
	Design Pressure(High)	PSIG	550	550
	Design Pressure(Low)	PSIG	240	240
	Sound Pressure Level (H/M/L)	dB (A)	65/-/-	65/-/-
	Sound Power Level (H/M/L)	dB (A)	75/-/-	75/-/-
Dimension (WXHXD)	inch	39 1/2X31 7/64X16 13/16	39 1/2X31 7/64X16 13/16	
Dimension of Carton Box (LXWXH)	inch	42 1/2X19X33	42 1/2X19X33	
Dimension of Package (LXWXH)	inch	42 21/32X19 13/64X33 21/32	42 21/32X19 13/64X33 21/32	
Net Weight	lb	158.8	158.8	
Gross Weight	lb	169.8	169.8	
Refrigerant		R410A	R410A	
Refrigerant Charge	oz	91.71	91.71	
Connection Pipe	Length	ft	24.6	24.6
	Gas Additional Charge	oz/ft	0.5	0.5
	Outer Diameter Liquid Pipe	inch	1/4	1/4
	Outer Diameter Gas Pipe	inch	5/8	5/8
	Max Distance Height	ft	32 3/16	32 3/16
	Max Distance Length	ft	98 27/64	98 27/64
	Note:The connection pipe applies metric diameter.			

The above data is subject to change without notice; please refer to the nameplate of the unit.

Model			LIVV30HP230V1A	
Product Code			CB432022100 CB434017700	
Power Supply	Rated Voltage	V~	208/230	
	Rated Frequency	Hz	60	
	Phases		1	
Power Supply Mode			Outdoor	
Cooling Capacity		Btu/h	30000	
Heating Capacity		Btu/h	30000	
Cooling Power Input		W	2839	
Heating Power Input		W	2750	
Cooling Power Current		A	12.4	
Heating Power Current		A	12	
Rated Input		W	3800	
Rated Current		A	16.5	
Rated Heating Current		A	16.5	
Air Flow Volume(SH/H/M/L)		CFM	820/706/589/441	
Dehumidifying Volume		Pint/h	6.34	
EER		(Btu/h)/W	10.55	
COP		(Btu/h)/W	11.26	
SEER			18	
HSPF			9	
Application Area		yd ²	41.86-62.19	
Indoor Unit	Model of indoor unit		LIVV30HP230V1AH	
	Indoor Unit Product Code		CB432N22100 CB434N17700	
	Fan Type		Cross-flow	
	Diameter Length(DXL)		inch	Φ4 1/4X20 9/16
	Fan Motor Cooling Speed (SH/H/M/L)		r/min	1550/1300/1150/850
	Fan Motor Heating Speed (SH/H/M/L)		r/min	1500/1300/1150/1000
	Output of Fan Motor		W	70
	Fan Motor RLA		A	0.55
	Fan Motor Capacitor		μF	/
	Evaporator Form			Aluminum Fin-copper Tube
	Pipe Diameter		inch	Φ9/32
	Row-fin Gap		inch	2-1/16
	Coil Length (LXDXW)		inch	42 9/32X1X15
	Swing Motor Model			MP24BA
	Output of Swing Motor		W	1.5
	Fuse		A	5
	Sound Pressure Level (SH/H/M/L)		dB (A)	55/50/46/37
	Sound Power Level (SH/H/M/L)		dB (A)	65/60/56/47
	Dimension (WXHXD)		inch	53 9/64X12 53/64X9 61/64
	Dimension of Carton Box (LXWXH)		inch	56 39/64X16 29/64X13 55/64
	Dimension of Package (LXWXH)		inch	56 47/64X16 37/64X14 7/16
Net Weight		lb	43	
Gross Weight		lb	52.9	

Outdoor Unit	Model of Outdoor Unit		LIVV30HP230V1AO	
	Outdoor Unit Product Code		CB432W22100	
	Compressor Manufacturer/Trademark		ZHUHAI LANDA COMPRESSOR CO.LTD.	
	Compressor Model		QXFS-D25zX090H	
	Compressor Oil		FW68DA or equivalent	
	Compressor Type		Rotary	
	Compressor Locked Rotor Amp (L.R.A)		/	
	Compressor RLA	A		16.9
	Compressor Power Input	W		2420
	Overload Protector			HPC115/95U1 KSD115°C
	Throttling Method			Electron expansion valve
	Operation temp	°F		61~86
	Ambient temp (cooling)	°F		-4~105
	Ambient temp (heating)	°F		-13~75
	Condenser Form			Aluminum Fin-copper Tube
	Pipe Diameter	inch		Φ9/32
	Rows-fin Gap	inch		2-1/16
	Coil Length (LXD _X W)	inch		37 31/64X1 1/2X29 29/64
	Fan Motor Speed	rpm		880
	Output of Fan Motor	W		92
	Fan Motor RLA	A		0.7
	Fan Motor Capacitor	μF		/
	Air Flow Volume of Outdoor Unit	CFM		2354
	Fan Type			Axial-flow
	Fan Diameter	inch		Φ21 21/32
	Defrosting Method			Automatic Defrosting
	Climate Type			T1
	Isolation			I
	Moisture Protection			IPX4
	Design Pressure(High)	PSIG		550
	Design Pressure(Low)	PSIG		240
	Sound Pressure Level (H/M/L)	dB (A)		60/-/-
Sound Power Level (H/M/L)	dB (A)		70/-/-	
Dimension (WXHXD)	inch		39 1/2X31 7/64X16 13/16	
Dimension of Carton Box (LXWXH)	inch		42 1/2X19X33	
Dimension of Package (LXWXH)	inch		42 21/32X19 13/64X33 21/32	
Net Weight	lb		138.9	
Gross Weight	lb		149.9	
Refrigerant			R410A	
Refrigerant Charge	oz		77.6	
Connection Pipe	Length	ft	24.6	
	Gas Additional Charge	oz/ft	0.2	
	Outer Diameter Liquid Pipe	inch	1/4	
	Outer Diameter Gas Pipe	inch	5/8	
	Max Distance Height	ft	32 13/16	
	Max Distance Length	ft	82	
Note:The connection pipe applies metric diameter.				

The above data is subject to change without notice; please refer to the nameplate of the unit.

Outdoor Unit	Model of Outdoor Unit		LIVV36HP230V1AO
	Outdoor Unit Product Code		CB432W23000
	Compressor Manufacturer/Trademark		ZHUHAI LANDA COMPRESSOR CO.LTD.
	Compressor Model		QXFS-D25zX090H
	Compressor Oil		FW68DA or equivalent
	Compressor Type		Rotary
	Compressor Locked Rotor Amp (L.R.A)		24
	Compressor RLA	A	16.9
	Compressor Power Input	W	2420
	Overload Protector		HPC115/95U1 KSD115°C
	Throttling Method		Electron expansion valve
	Operation temp	°F	61~86
	Ambient temp (cooling)	°F	-4~105
	Ambient temp (heating)	°F	-13~75
	Condenser Form		Aluminum Fin-copper Tube
	Pipe Diameter	inch	Φ9/32
	Rows-fin Gap	inch	2-1/16
	Coil Length (LXDXW)	inch	37 31/64X1 1/2X29 29/64
	Fan Motor Speed	rpm	880
	Output of Fan Motor	W	92
	Fan Motor RLA	A	0.7
	Fan Motor Capacitor	μF	/
	Air Flow Volume of Outdoor Unit	CFM	2354
	Fan Type		Axial-flow
	Fan Diameter	inch	Φ21 21/32
	Defrosting Method		Automatic Defrosting
	Climate Type		T1
	Isolation		I
	Moisture Protection		IPX4
	Design Pressure(High)	PSIG	550
	Design Pressure(Low)	PSIG	240
	Sound Pressure Level (H/M/L)	dB (A)	61/-/-
	Sound Power Level (H/M/L)	dB (A)	71/-/-
Dimension (WXHXD)	inch	39 1/2X31 7/64X16 13/16	
Dimension of Carton Box (LXWXH)	inch	42 1/2X19X33	
Dimension of Package (LXWXH)	inch	42 21/32X19 13/64X33 21/32	
Net Weight	lb	140	
Gross Weight	lb	151	
Refrigerant		R410A	
Refrigerant Charge	oz	88.2	
Connection Pipe	Length	ft	24.6
	Gas Additional Charge	oz/ft	0.2
	Outer Diameter Liquid Pipe	inch	1/4
	Outer Diameter Gas Pipe	inch	5/8
	Max Distance Height	ft	32 13/16
	Max Distance Length	ft	82
	Note:The connection pipe applies metric diameter.		

The above data is subject to change without notice; please refer to the nameplate of the unit.

2.2 Capacity Variation Ratio According to Temperature

Heating operation ambient temperature range is -4°F~75°F

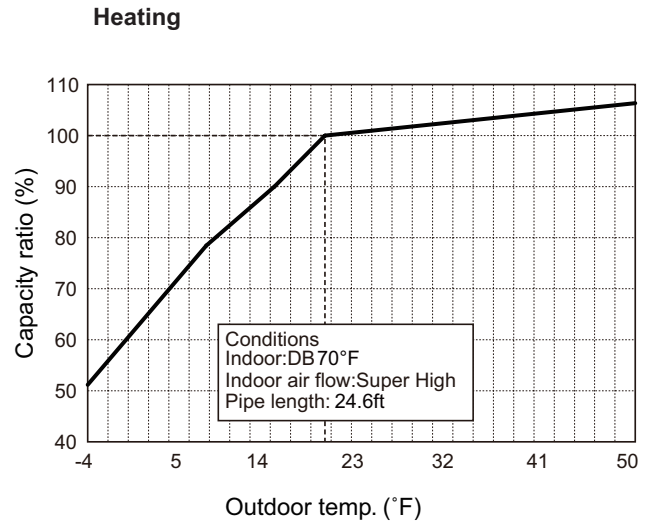
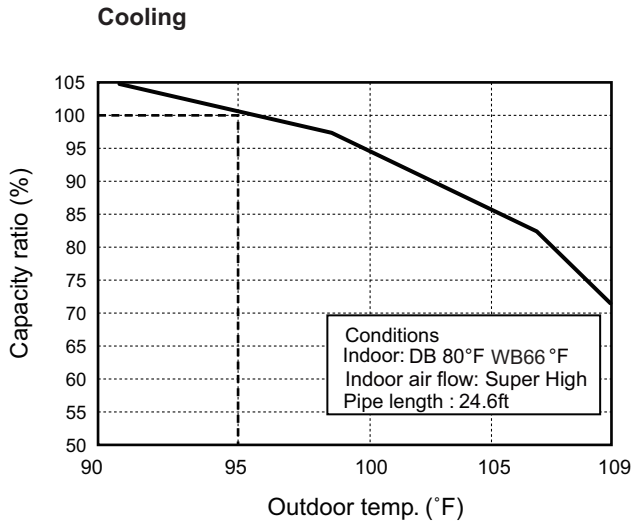

Heating operation ambient temperature range is -13°F~75°F

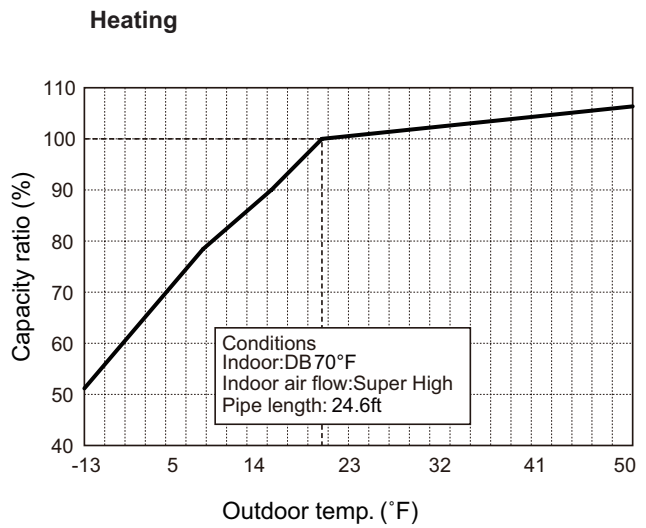
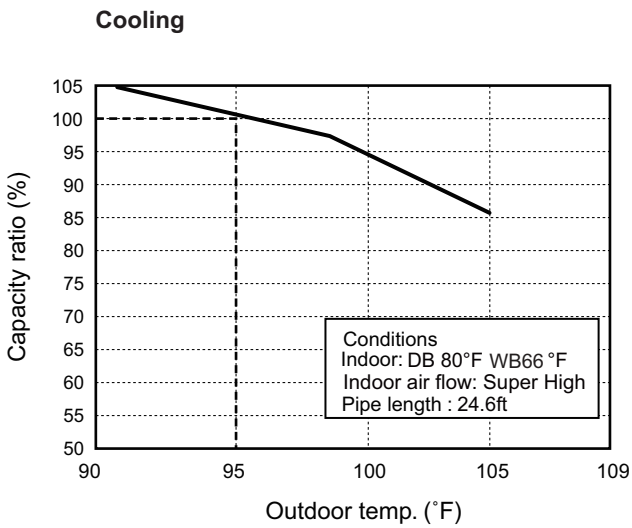

Heating operation ambient temperature range is -31°F~75°F

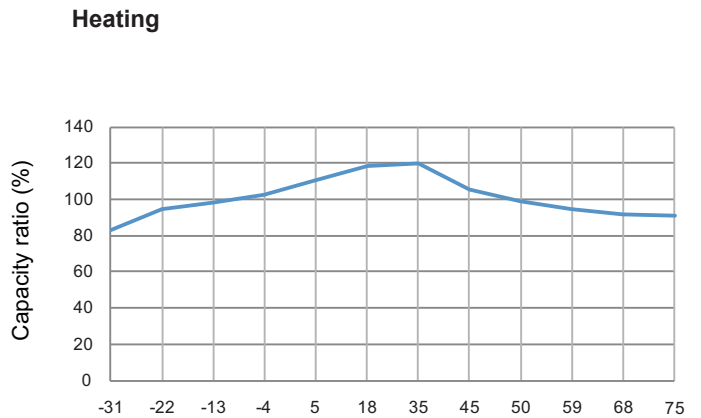
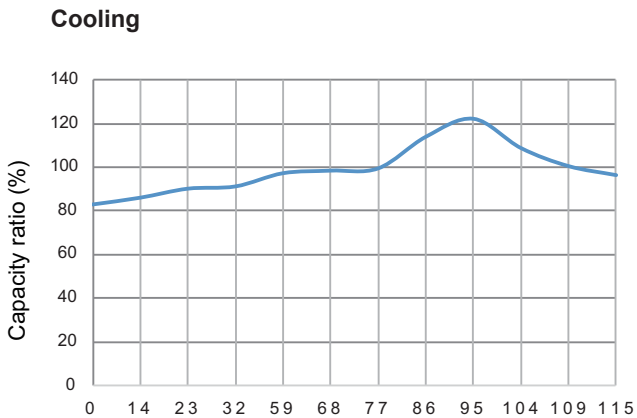

2.3 Noise Curve

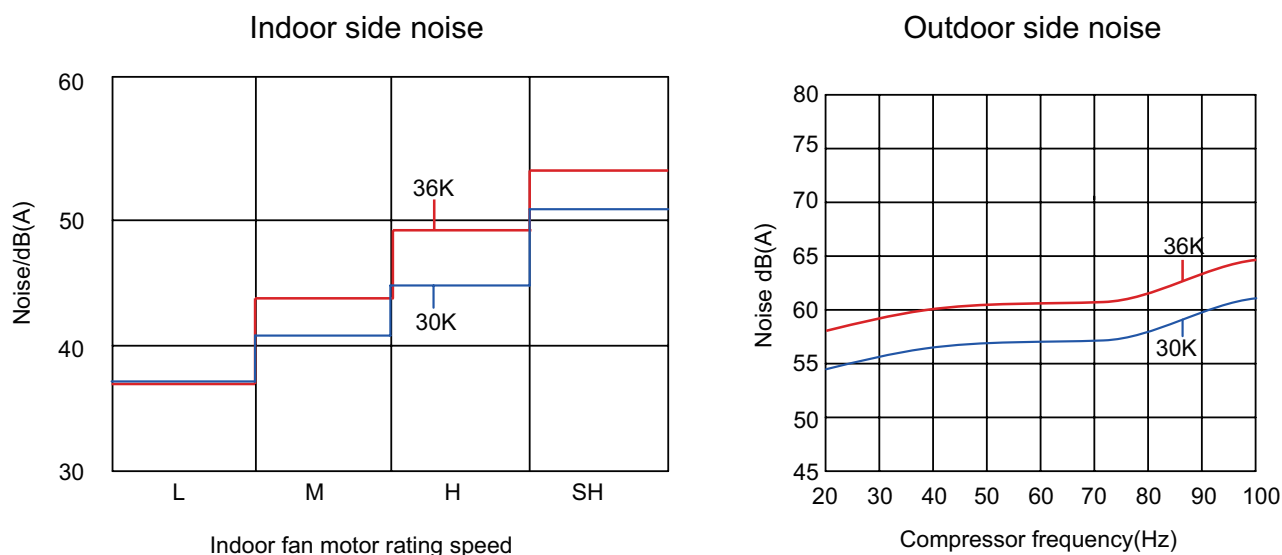

2.4 Cooling and Heating Data Sheet in Rated Frequency

Cooling:

Rated cooling condition(°F) (DB/WB)		Model	Pressure of gas pipe connecting indoor and outdoor unit	Inlet and outlet pipe temperature of heat exchanger		Fan speed of indoor unit	Fan speed of outdoor unit	Compressor revolution (rps)
Indoor	Outdoor			T1 (°F)	T2 (°F)			
80/66	95/-	30K	P (PSIG)	46.8 to 52.8	127 to 96.8	Super High	High	46
80/66	95/-	36K	130~145	46.8 to 52.8	127 to 96.8	Super High	High	37

Heating:

Rated heating condition(°F) (DB/WB)		Model	Pressure of gas pipe connecting indoor and outdoor unit	Inlet and outlet pipe temperature of heat exchanger		Fan speed of indoor unit	Fan speed of outdoor unit	Compressor revolution (rps)
Indoor	Outdoor			T1 (°F)	T2 (°F)			
70/-	20/19	30K	P (PSIG)	134.4 to 102	36 to 39	Super High	High	46
70/-	20/19	36K	507~550	134.4 to 102	36 to 39	Super High	High	34

Instruction:

T1: Inlet and outlet pipe temperature of evaporator

T2: Inlet and outlet pipe temperature of condenser

P: Pressure at the side of big valve

Connection pipe length: 24.6ft.

3. Outline Dimension Diagram

3.1 Indoor Unit

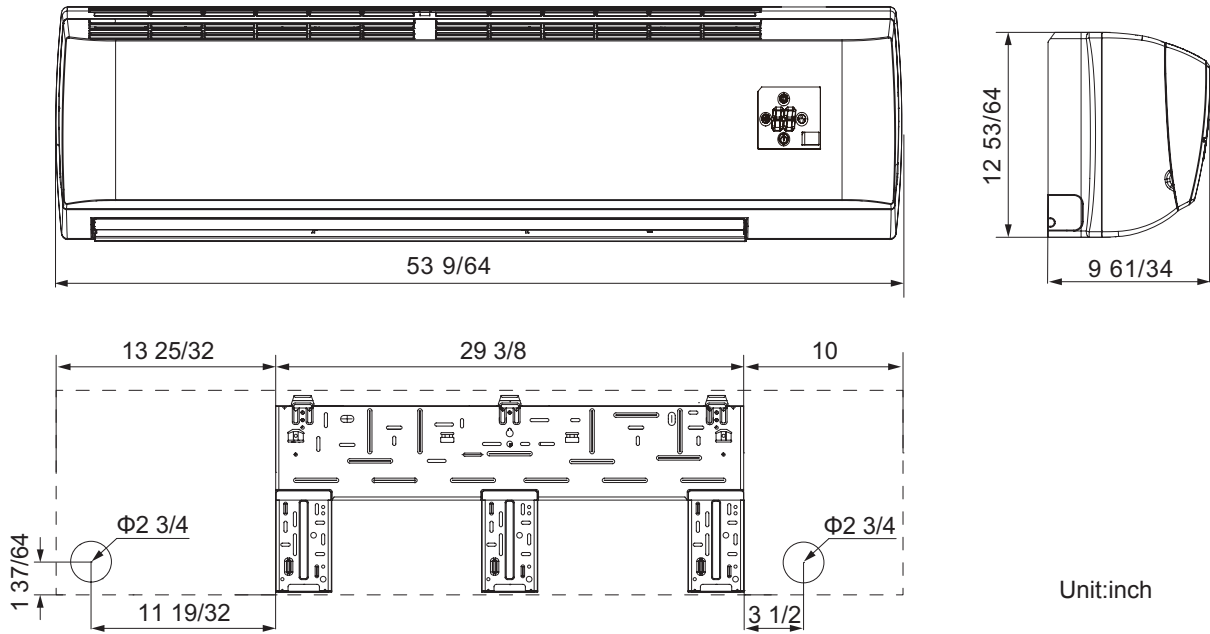

3.2 Outdoor Unit

- VIR36HP230V1CO VIR30HP230V1BO VIR36HP230V1BO
LIVS36HP230V1CO LIVS36HP230V1AO LIVO36HP230V1AO
LIVV36HP230V1AO LIVV30HP230V1AO LIVV30HP230V1AO

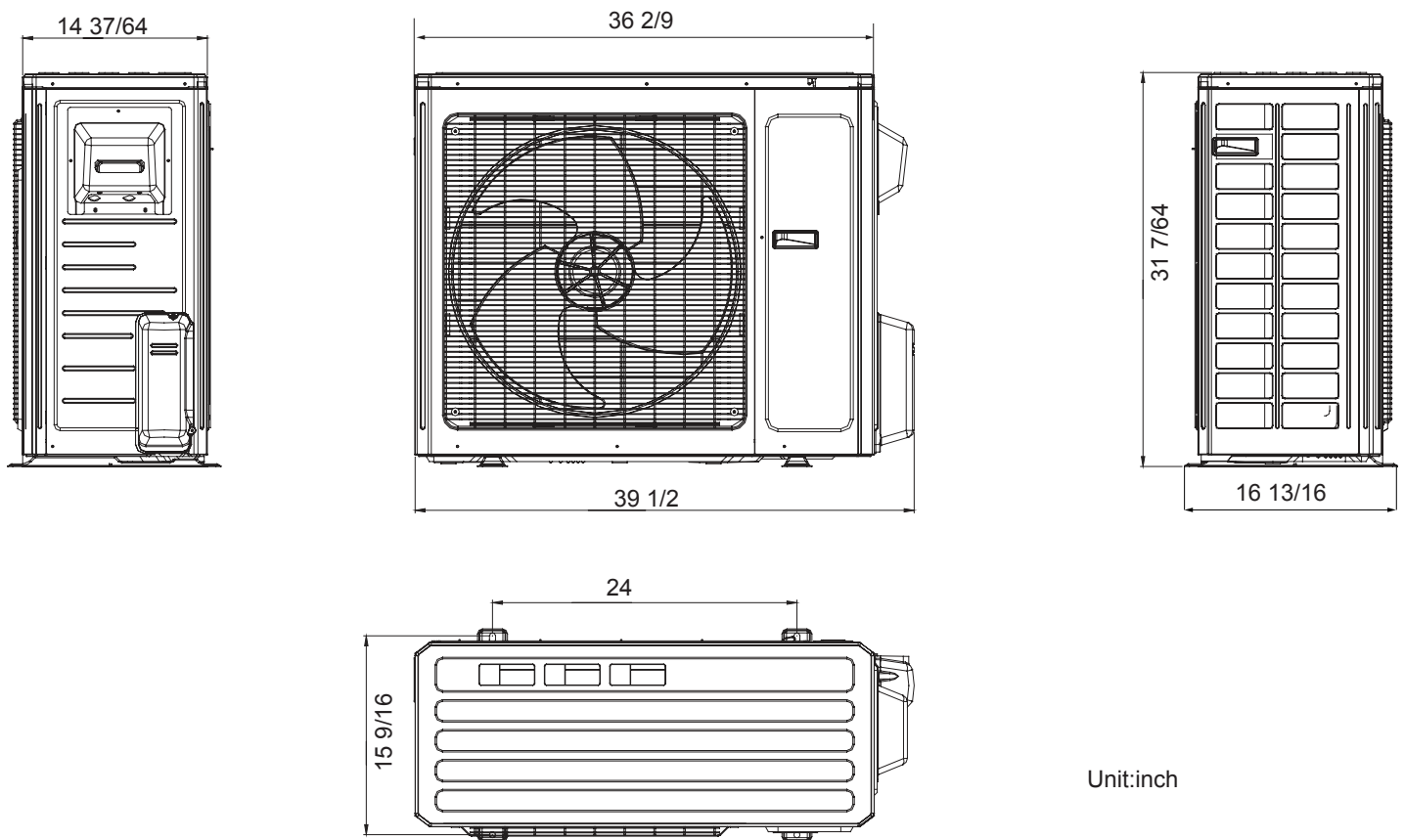

VIRU36HP230V1AO
VIRU30HP230V1AO

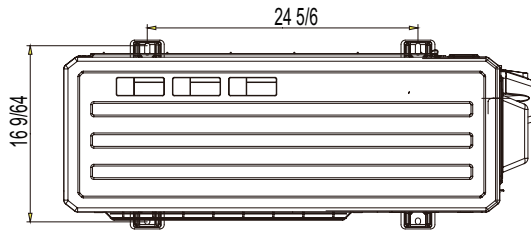
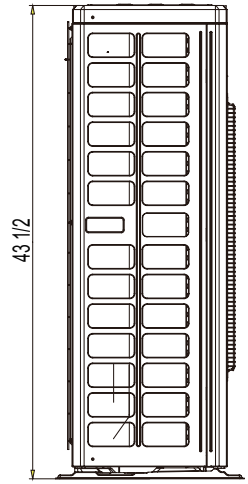
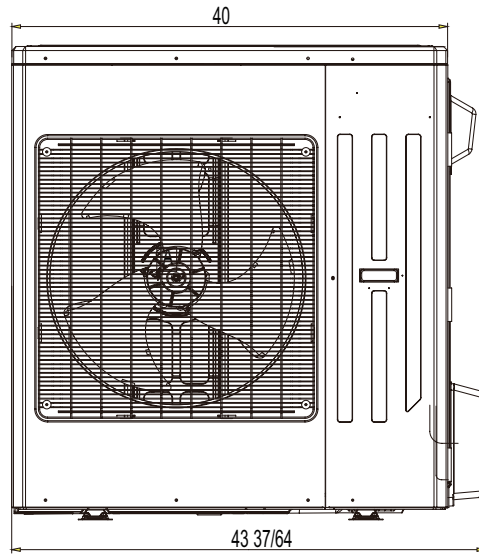
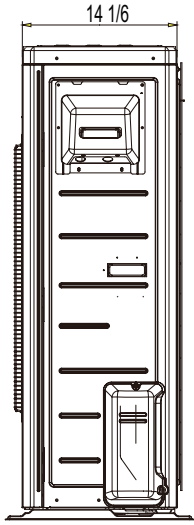

Unit:inch

4. Refrigerant System Diagram

30K except :GWH30QF-D3DNB2I
Cooling only model

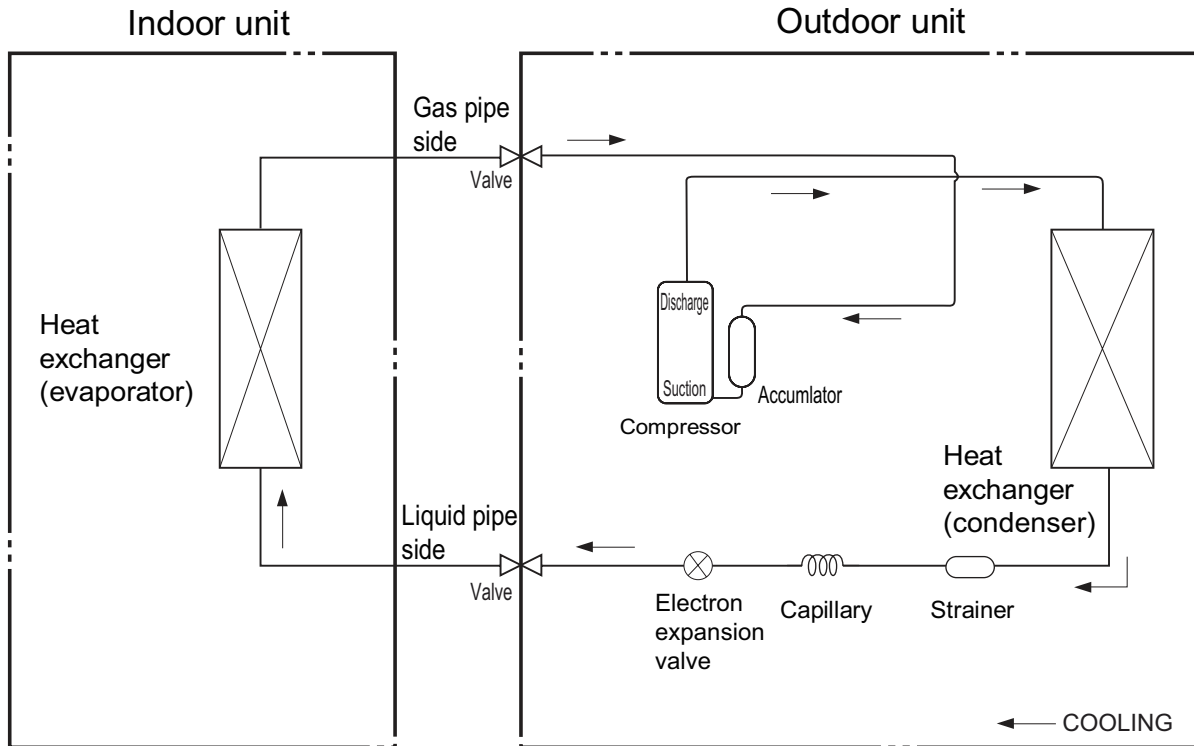

Cooling and heating model

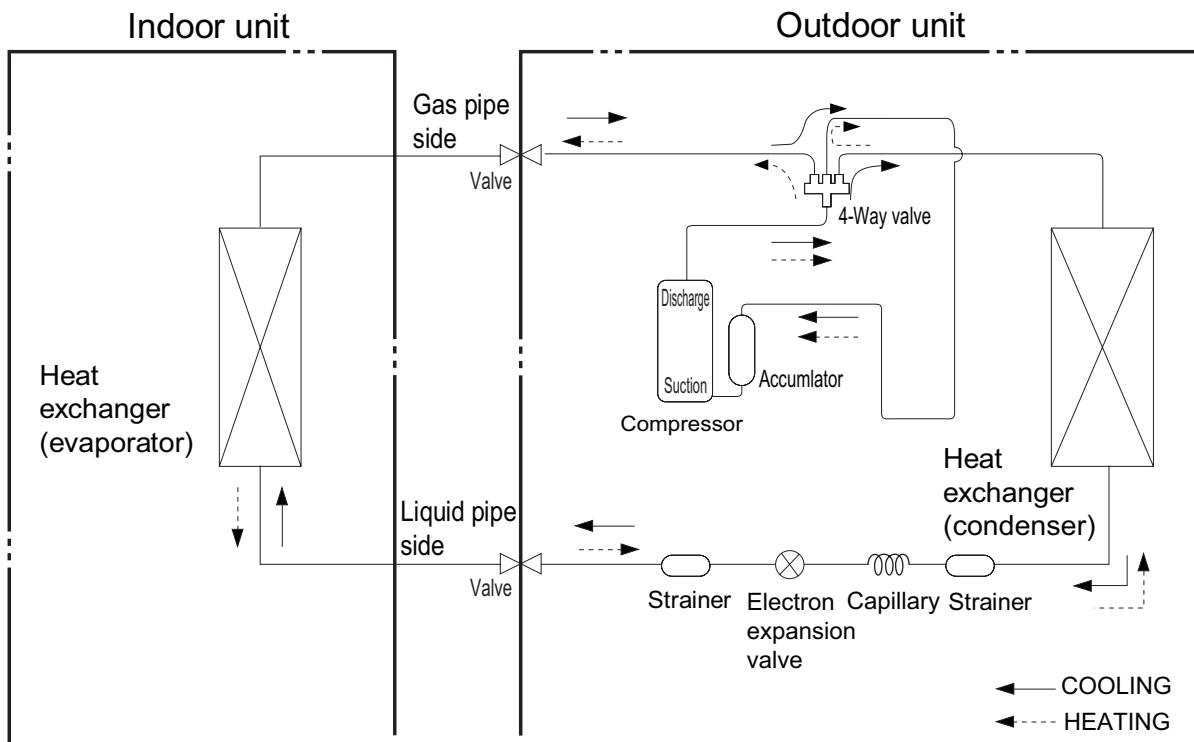

Connection pipe specification:
Liquid pipe:1/4 inch
Gas pipe:5/8 inch

36K except VIRU36HP230V1A :

Cooling only model

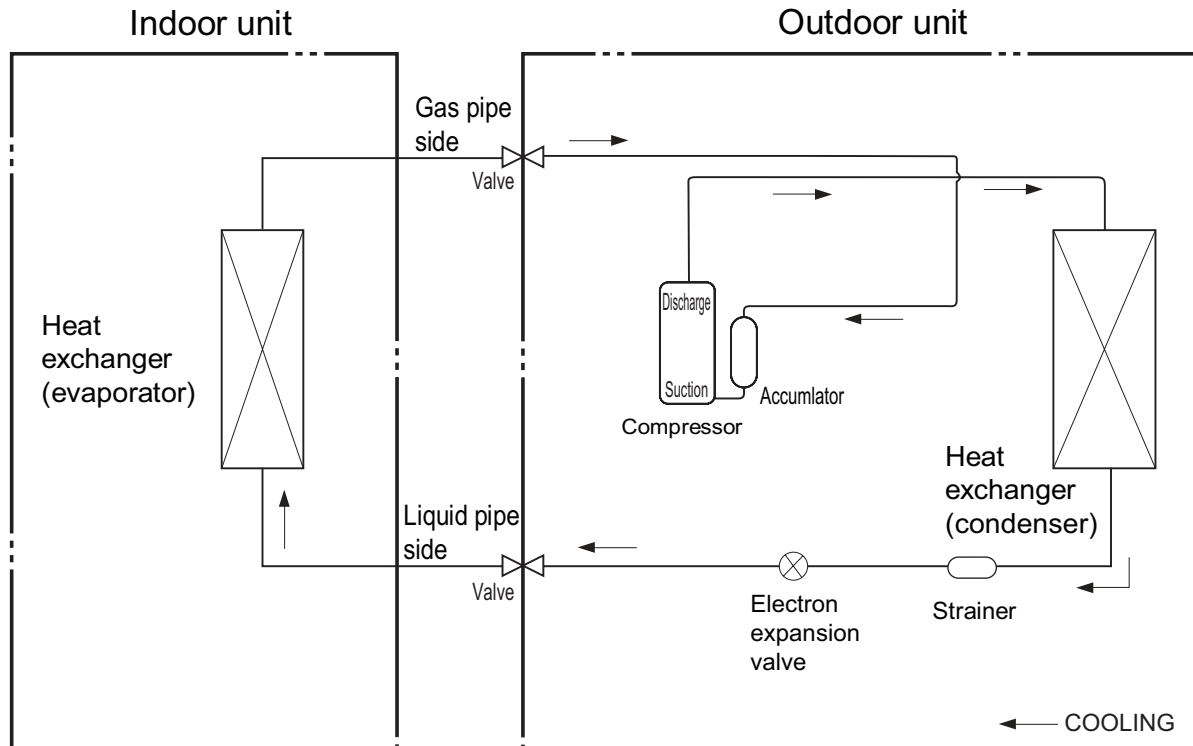

Cooling and heating model

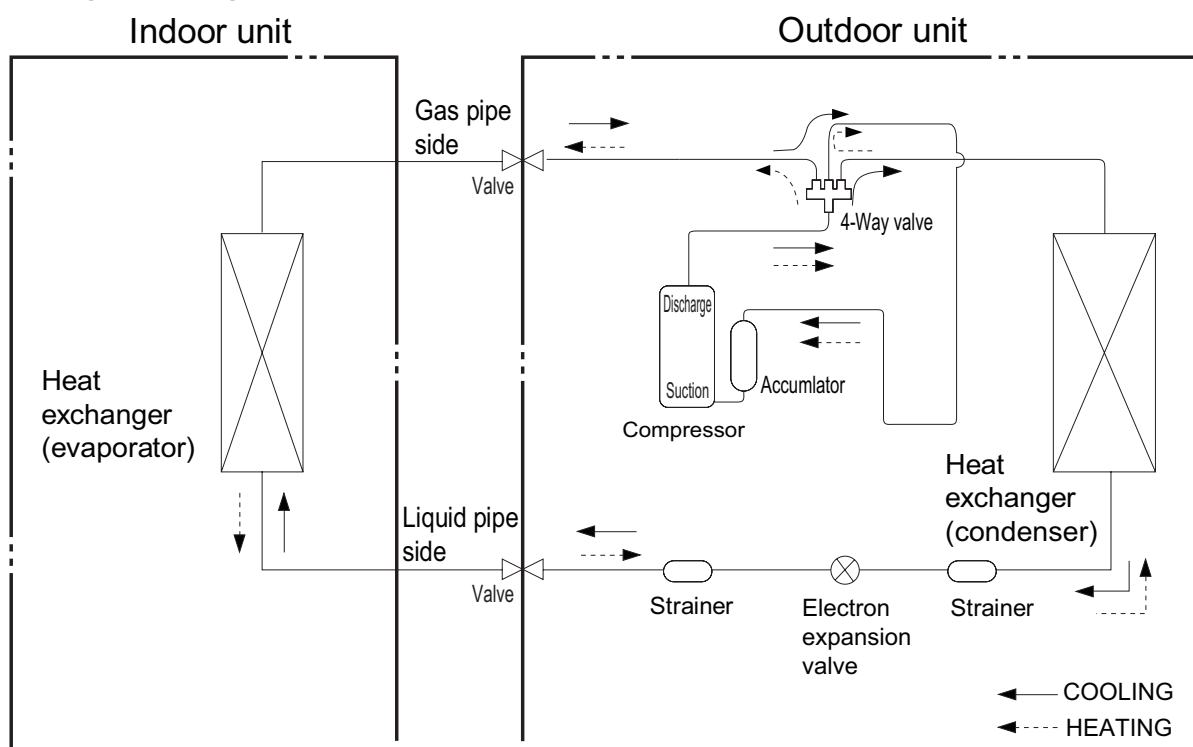

Connection pipe specification:

Liquid pipe:1/4 inch

Gas pipe:5/8 inch

5. Electrical Part

5.1 Wiring Diagram

• Instruction

Symbol	Symbol Color	Symbol	Symbol Color	Symbol	Name
WH	White	GN	Green	CAP	Jumper cap
YE	Yellow	BN	Brown	COMP	Compressor
RD	Red	BU	Blue		Grounding wire
YEGN	Yellow/Green	BK	Black	/	/
VT	Violet	OG	Orange	/	/

Note: Jumper cap is used to determine fan speed and the swing angle of horizontal lover for this model.

• Indoor Unit

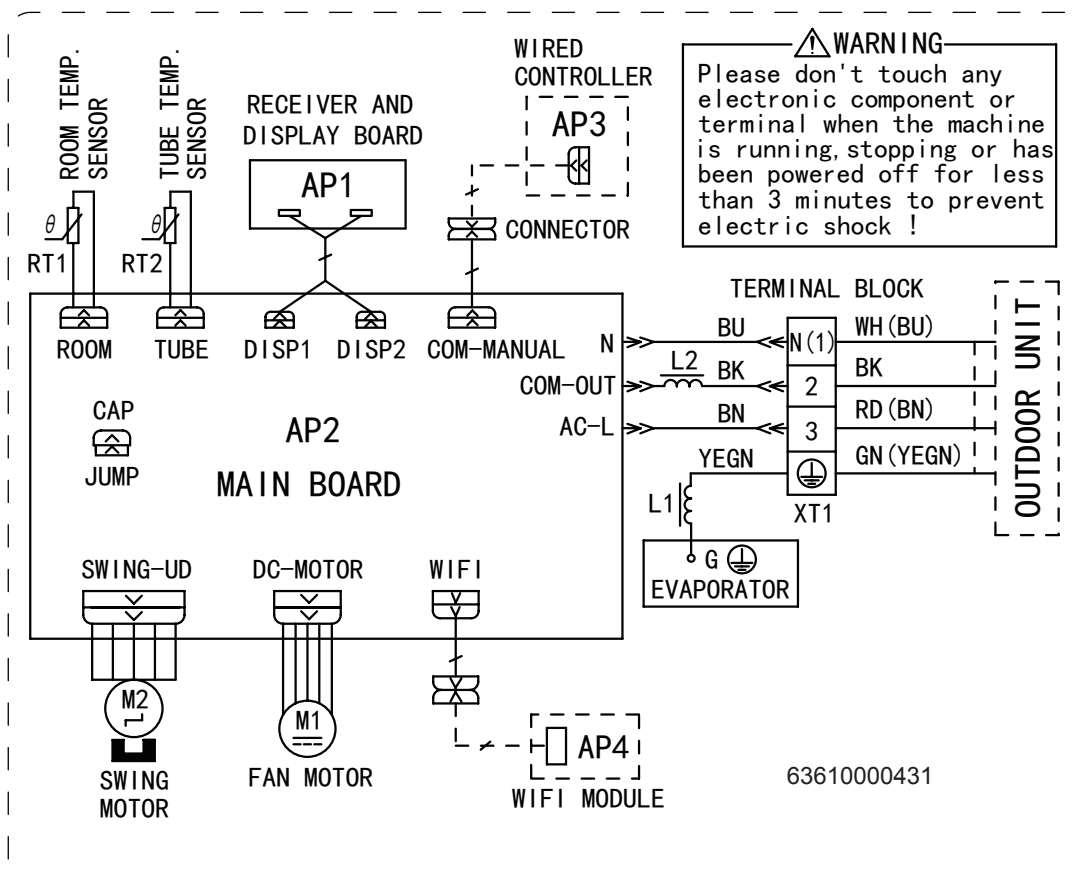

• Outdoor Unit

VIR30HP230V1BO VIR36HP230V1BO VIR36HP230V1CO LIVS36HP230V1CO

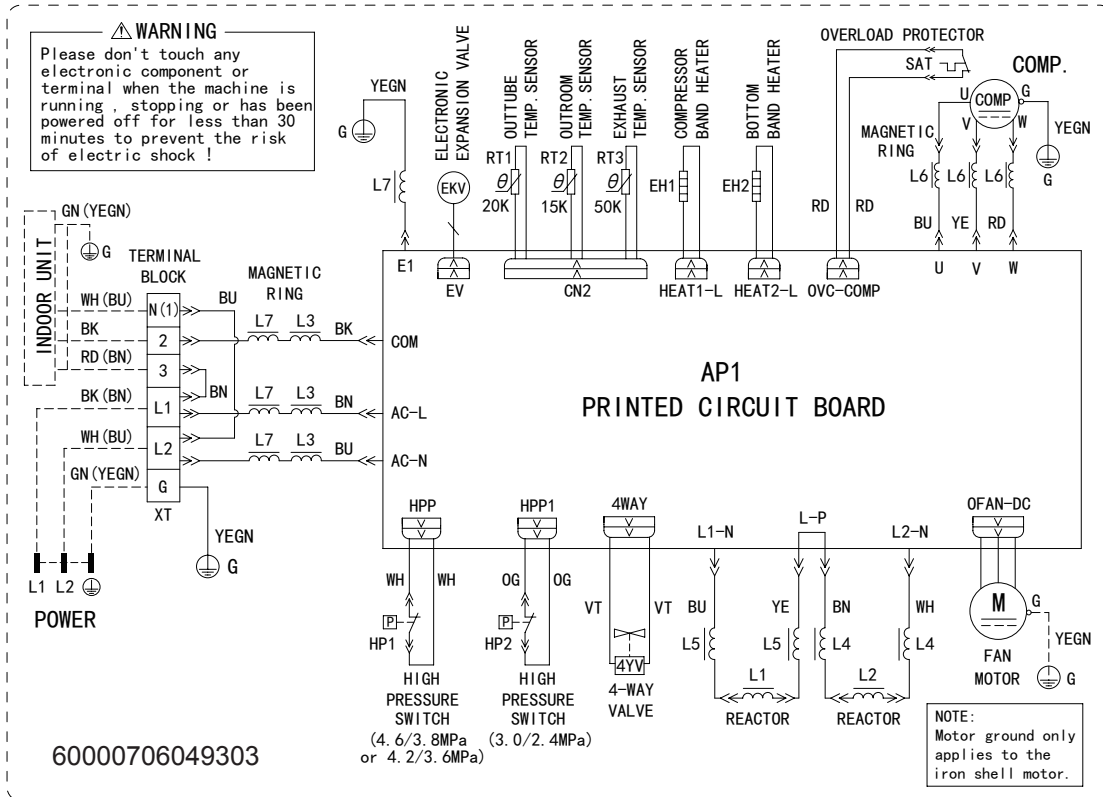

VIRU36HP230V1AO VIRU30HP230V1AO

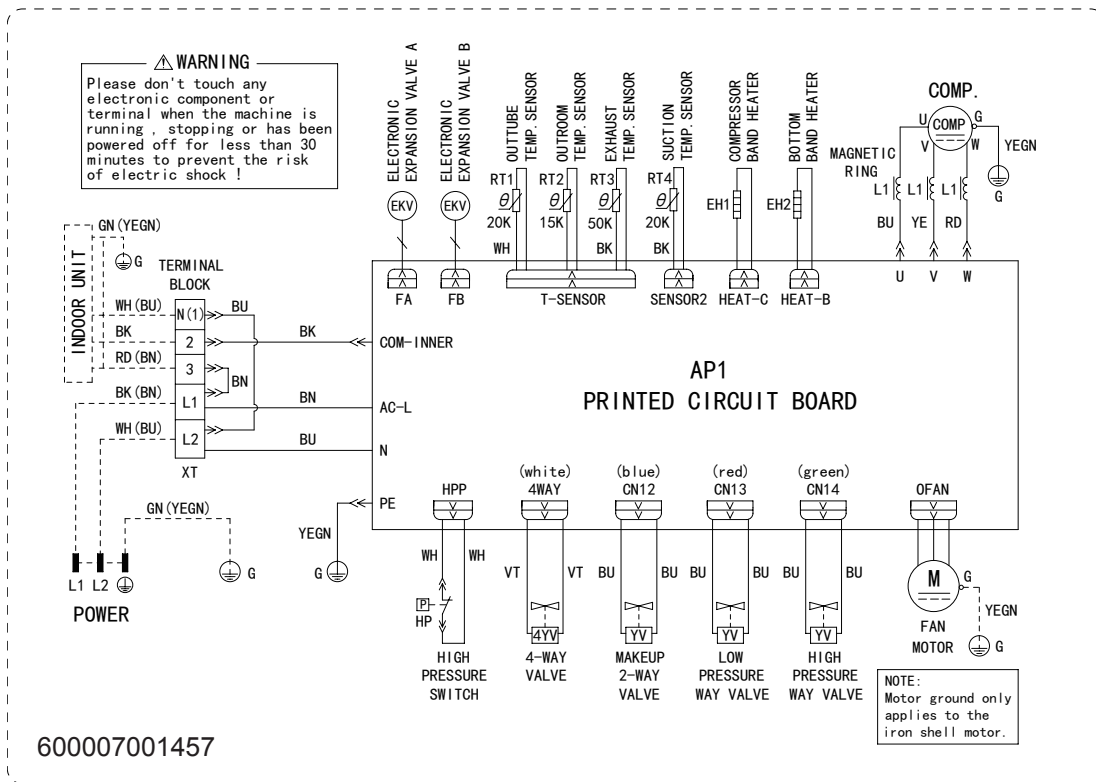

LIVV30HP230V1AO LIVV36HP230V1AO

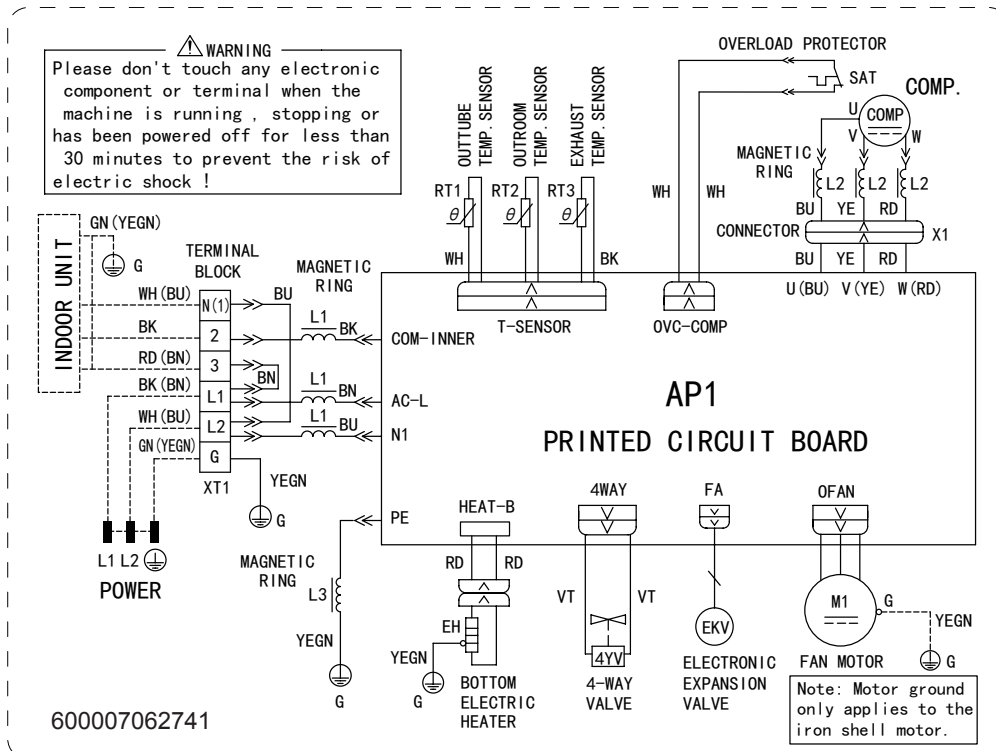

The above data is subject to change without notice. Please refer to the nameplate of the unit.

5.2 PCB Printed Diagram

Indoor Unit

• Top View

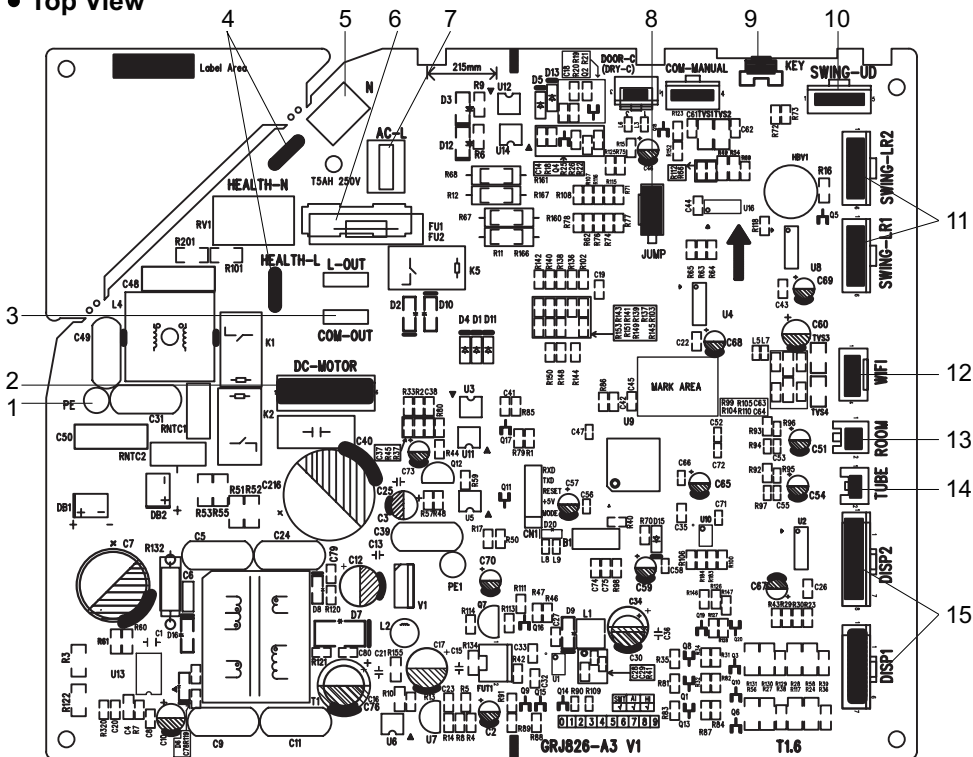

1	Grounding wire
2	DC motor needle stand
3	Communication terminal for outdoor unit
4	Interface of health function(only for the mode with this function)
5	Interface of neutral wire
6	Fuse
7	Interface of live wire
8	Needle stand for jumper cap
9	Auto button
10	up&down swing interface
11	Left&right swing interface
12	Wifi interface
13	Interface of ambient temperature sensor
14	Interface of tube temperature sensor
15	Display interface

• Bottom View

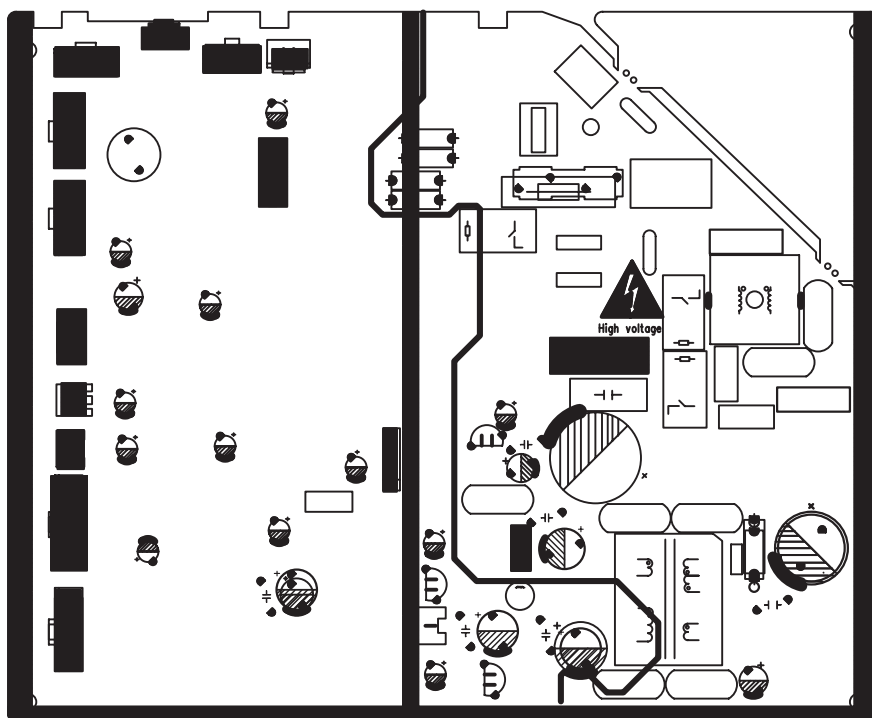

● Top view VIRU36HP230V1AO VIRU30HP230V1AO

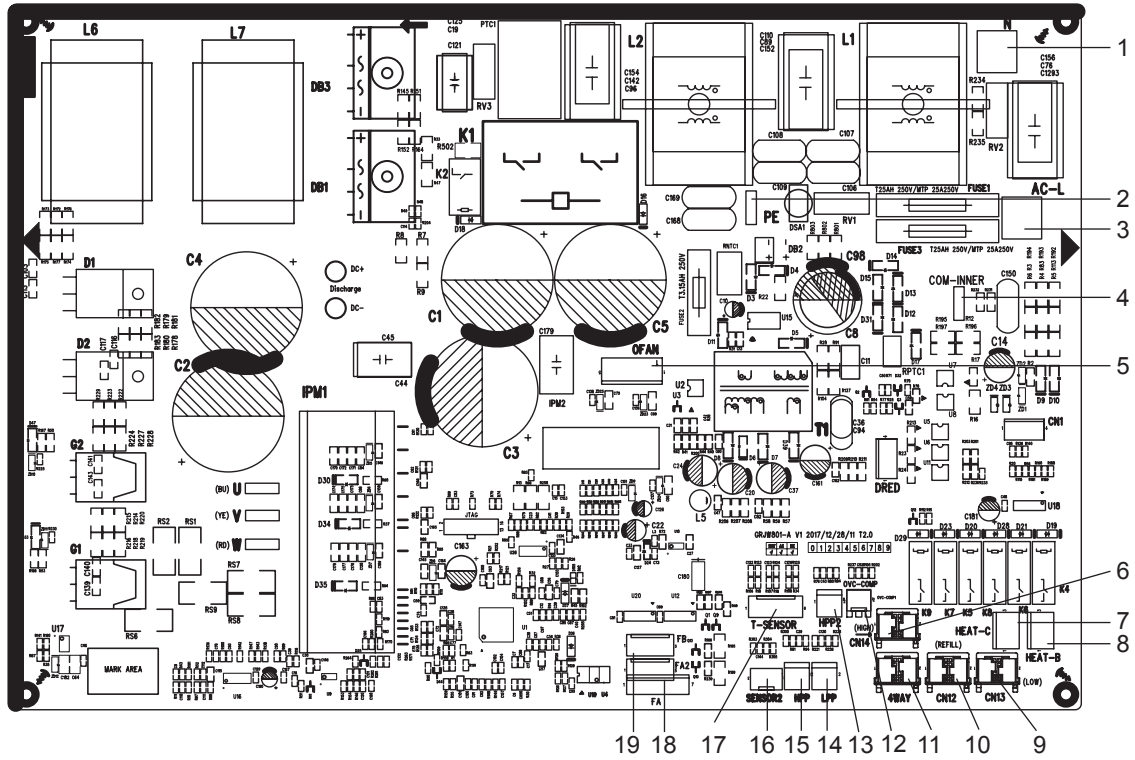

No.	Name	No.	Name	No.	Name
1	Neutral wire	8	Interface B of electric heating	15	Terminal for high pressure protection
2	Grounding wire	9	Terminal of low pressure valve	16	Interface 2 of temperature sensor
3	Live wire	10	Terminal of 2-way valve	17	Interface of temperature sensor
4	Communication interface	11	Terminal of 4-way valve	18	Terminal A of electronic expansion valve
5	Terminal of outdoor fan	12	Terminal of compressor overload protection	19	Terminal B of electronic expansion valve
6	Terminal of high pressure valve	13	Terminal for 2 high pressure protection		
7	Interface C of electric heating	14	Terminal for low pressure protection		

● Bottom view

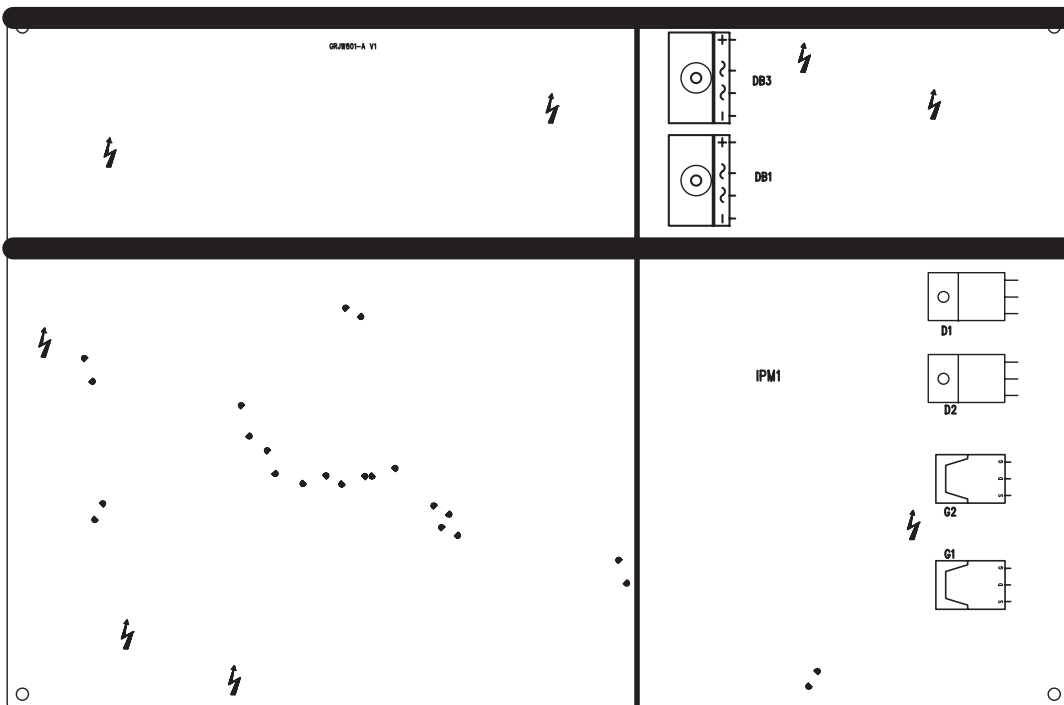

LIVV30HP230V1A0

• Top view

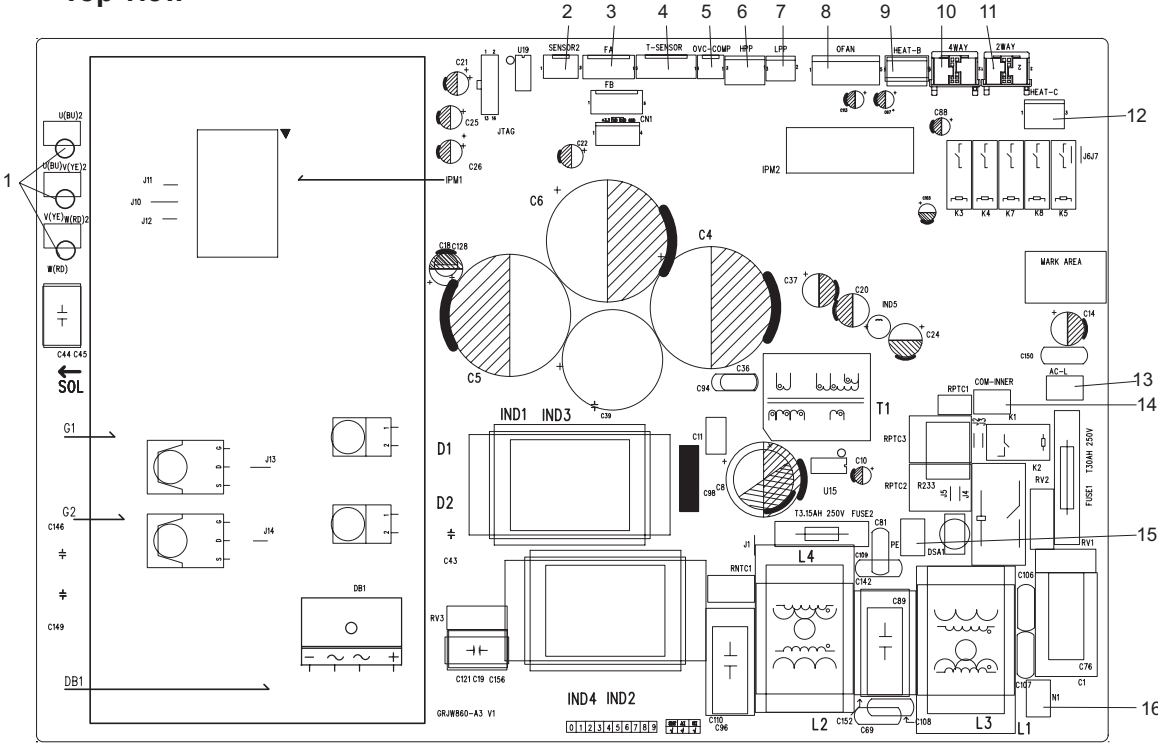

No.	Name
1	Compressor wiring terminal for U V W
2	Suction temperature sensor
3	Terminal of electronic expansion valve
4	Terminal of temperature sensor
5	Overload terminal of compressor
6	Low-pressure protection terminal
7	High-pressure protection terminal
8	Terminal of outdoor fan
9	Interface of electric heating belt of chassis
10	4-way valve
11	2-way valve
12	Terminal of compressor electric heater
13	Live wire
14	Communication wire
15	Earthing wire
16	Neutral wire

• Bottom view

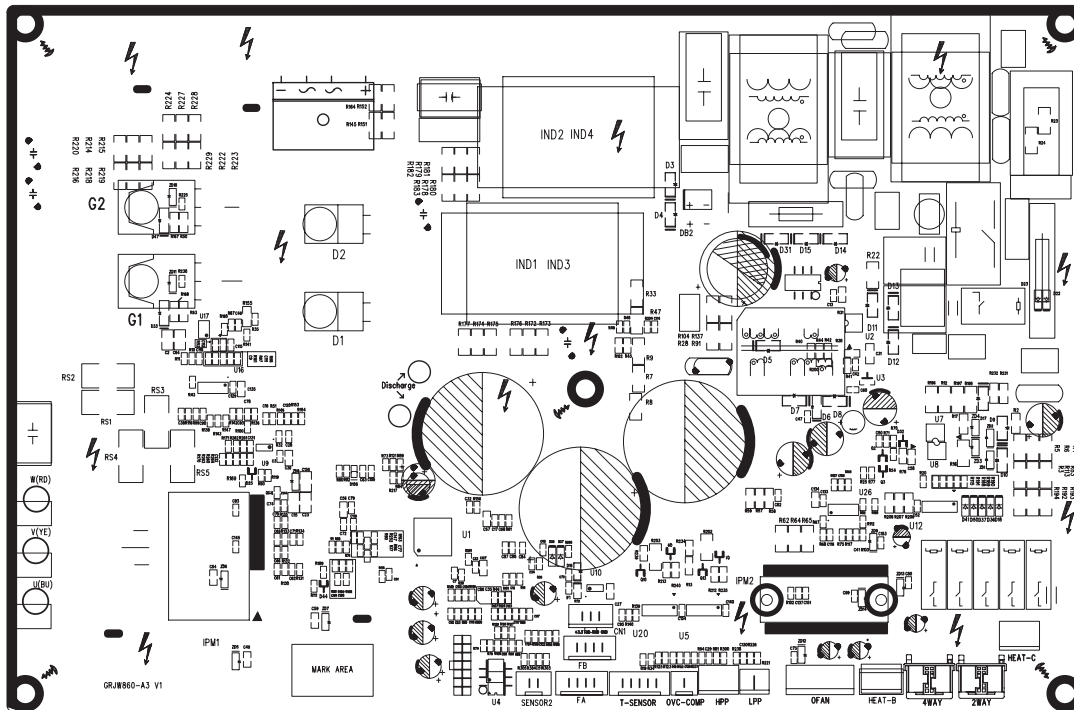

6. Function and Control

6.1 Remote Controller Introduction of YAN1F6F(WiFi)



Introduction for icons on display screen

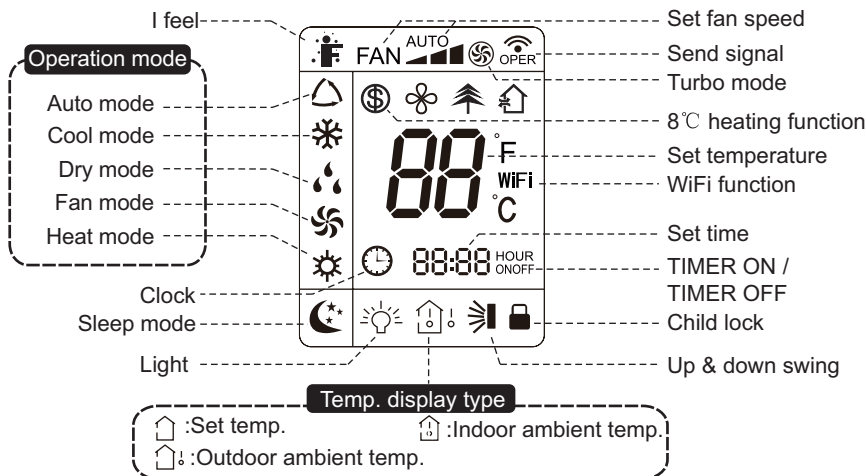

Introduction for buttons on remote controller

Note:

- This is a general use remote controller, it could be used for the air conditioners with multifunction; For some function, which the model doesn't have, if press the corresponding button on the remote controller that the unit will keep the original running status.
- After putting through the power, the air conditioner will give out a sound. Operation indicator "⏻" is ON (red indicator, the colour is different for different models). After that, you can operate the air conditioner by using remote controller.
- Under on status, pressing the button on the remote controller, the signal icon "📶" on the display of remote controller will blink once and the air conditioner will give out a "de" sound, which means the signal has been sent to the air conditioner.
- Under off status, set temperature and clock icon will be displayed on the display of remote controller (If timer on, timer off and light functions are set, the corresponding icons will be displayed on the display of remote controller at the same time); Under on status, the display will show the corresponding set function icons.

1. ON/OFF button

Press this button to turn on the unit. Press this button again to turn off the unit.

2. MODE button

Press this button to select your required operation mode.

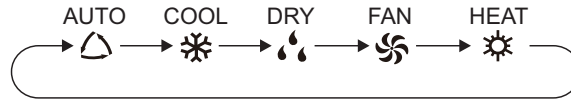

- When selecting auto mode, air conditioner will operate automatically according to ex-factory setting. Set temperature can't be adjusted and will not be displayed as well. Press "FAN" button can adjust fan speed. Press "SWING" button can adjust fan blowing angle.
- After selecting cool mode, air conditioner will operate under cool mode. Cool indicator on indoor unit is ON(This indicator is not available for some models). Press "▲" or "▼" button to adjust set temperature. Press "FAN" button to adjust fan speed. Press "SWING" button to adjust fan blowing angle.
- When selecting dry mode, the air conditioner operates at low speed under dry mode. Dry indicator on indoor unit is ON(This indicator is not available for some models). Under dry mode, fan speed can't be adjusted. Press "SWING" button to adjust fan blowing angle.
- When selecting fan mode, the air conditioner will only blow fan, no cooling and no heating. Press "FAN" button to adjust fan speed. Press "SWING" button to adjust fan blowing angle.
- When selecting heating mode, the air conditioner operates under heat mode. Heat indicator on indoor unit is ON(This indicator is not available for some models). Press "▲" or "▼" button to adjust set temperature. Press "FAN" button to adjust fan speed. Press "SWING" button to adjust fan blowing angle. (Cooling only unit won't receive heating mode signal. If setting heat mode with remote controller, press ON/OFF button can't start up the unit).

Note:

- For preventing cold air, after starting up heating mode, indoor unit will delay 1~5 minutes to blow air (actual delay time is depend on indoor ambient temperature).
- Set temperature range from remote controller: 16~30℃ ; Fan speed: auto, low speed, medium speed, high speed.

3. FAN button

Pressing this button can set fan speed circularly as: auto (AUTO), low(▲), medium(▲▲), high(▲▲▲).



Note:

- Under AUTO speed, air conditioner will select proper fan speed automatically according to ex-factory setting.
 - Fan speed under dry mode is low speed.
 - X-FAN function: Hold fan speed button for 2s in COOL or DRY mode, the icon "⊗" is displayed and the indoor fan will continue operation for a few minutes in order to dry the indoor unit even though you have turned off the unit. After energization, X-FAN OFF is defaulted. X-FAN is not available in AUTO, FAN or HEAT mode.
- This function indicates that moisture on evaporator of indoor unit will be blown after the unit is stopped to avoid mould.
- Having set X-FAN function on: After turning off the unit by pressing ON/OFF button indoor fan will continue running for a few minutes. at low speed. In this period, Hold fan speed button for 2s to stop indoor fan directly.
 - Having set X-FAN function off: After turning off the unit by pressing ON/OFF button, the complete unit will be off directly.

4. SWING button

Press this button can select up&down swing angle. Fan blow angle can be selected circularly as below:

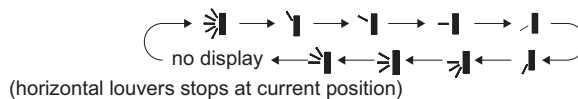

- When selecting "no display", air conditioner is blowing fan automatically. Horizontal louver will automatically swing up & down at maximum angle.
- When selecting "up, down, left, right", air conditioner is blowing fan at fixed position. Horizontal louver will stop at the fixed position.
- When selecting "up-angle, down-angle, left-angle, right-angle", air conditioner is blowing fan at fixed angle. Horizontal louver will send air at the fixed angle.
- Hold "no display" button above 2s to set your required swing angle. When reaching your required angle, release the button.

Note:

- "up-angle, down-angle, left-angle, right-angle" may not be available. When air conditioner receives this signal, the air conditioner will blow fan automatically.

5. TURBO button

Under COOL or HEAT mode, press this button to turn to quick COOL or quick HEAT mode. "⊗" icon is displayed on remote controller. Press this button again to exit turbo function and "⊗" icon will disappear.

6. ▲/▼ button

- Press "▲" or "▼" button once increase or decrease set temperature 1°C(1°F). . Holding "▲" or "▼" button, 2s later, set temperature on remote controller will change quickly. On releasing button after setting is finished, temperature indicator on indoor unit will change accordingly. (Temperature can't be adjusted under auto mode)
- When setting TIMER ON, TIMER OFF or CLOCK, press "▲" or "▼" button to adjust time. (Refer to CLOCK, TIMER ON, TIMER OFF buttons)

7. SLEEP button

Under COOL, HEAT or DRY mode, press this button to start up sleep function. "☾" icon is displayed on remote controller. Press this button again to cancel sleep function and "☾" icon will disappear.

8. TEMP button

By pressing this button, you can see indoor set temperature, indoor ambient temperature or outdoor ambient temperature on indoor units display. The setting on remote controller is selected circularly as below:

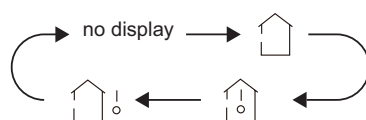

- When selecting "🏠" or no display with remote controller, temperature indicator on indoor unit displays set temperature.
- When selecting "🏠🌡️" with remote controller, temperature indicator on indoor unit displays indoor ambient temperature.
- When selecting "🏠🌡️🌡️" with remote controller, temperature indicator on indoor unit displays outdoor ambient temperature.

Note:

- Outdoor temperature display is not available for some models. At that time, indoor unit receives "🏠🌡️🌡️" signal, while it displays indoor set temperature.
- Its defaulted to display set temperature when turning on the unit. There is no display in the remote controller.
- Only for the models whose indoor unit has dual-8 display.
- When selecting displaying of indoor or outdoor ambient temperature, indoor temperature indicator displays corresponding temperature and automatically turn to display set temperature after three or five seconds.

9. WIFI button

Press "WiFi" button to turn on or turn off WiFi function. When WiFi function is turned on, the "WiFi" icon will be displayed on remote controller; Under status of remote controller off, press "MODE" and "WiFi" buttons simultaneously for 1s, WiFi module will restore to factory default setting.

10. LIGHT button

Press this button to turn off display light on indoor unit. "☹️" icon on remote controller disappears. Press this button again to turn on display light. "☺️" icon is displayed.

11. CLOCK button

Press this button to set clock time. "🕒" icon on remote controller will blink. Press "▲" or "▼" button within 5s to set clock time. Each pressing of "▲" or "▼" button, clock time will increase or decrease 1 minute. If hold "▲" or "▼" button, 2s later, time will change quickly. Release this button when reaching your required time. Press "CLOCK" button to confirm the time. "🕒" icon stops blinking.

Note:

- Clock time adopts 24-hour mode.
- The interval between two operation can't exceed 5s. Otherwise, remote controller will quit setting status. Operation for TIMER ON/TIMER OFF is the same.

12. TIMER ON / TIMER OFF button

• TIMER ON button

"TIMER ON" button can set the time for timer on. After pressing this button, "🕒" icon disappears and the word "ON" on remote controller blinks. Press "▲" or "▼" button to adjust TIMER ON setting. After each pressing "▲" or "▼" button, TIMER ON setting will increase or decrease 1min. Hold "▲" or "▼" button, 2s later, the time will change quickly until reaching your required time. Press "TIMER ON" to confirm it. The word "ON" will stop blinking. "🕒" icon resumes displaying. Cancel TIMER ON: Under the condition that TIMER ON is started up, press "TIMER ON" button to cancel it.

• TIMER OFF button

"TIMER OFF" button can set the time for timer off. After pressing this button, "🕒" icon disappears and the word "OFF" on remote controller blinks. Press "▲" or "▼" button to adjust TIMER OFF setting. After each pressing "▲" or "▼" button, TIMER OFF setting will increase or decrease 1min. Hold "▲" or "▼" button, 2s later, the time will change quickly until reaching your required time. Press "TIMER OFF" word "OFF" will stop blinking. "🕒" icon resumes displaying. Cancel TIMER OFF. Under the condition that TIMER OFF is started up, press "TIMER OFF" button to cancel it.

Note:

- Under on and off status, you can set TIMER OFF or TIMER ON simultaneously.
- Before setting TIMER ON or TIMER OFF, please adjust the clock time.
- After starting up TIMER ON or TIMER OFF, set the constant circulating valid. After that, air conditioner will be turned on or turned off according to setting time. ON/OFF button has no effect on setting. If you don't need this function, please use remote controller to cancel it.

Function introduction for combination buttons

1. Energy-saving function

Under cooling mode, press "TEMP" and "CLOCK" buttons simultaneously to start up or turn off energy-saving function. When energy-saving function is started up, "SE" will be shown on remote controller, and air conditioner will adjust the set temperature automatically according to ex-factory setting to reach to the best energy-saving effect. Press "TEMP" and "CLOCK" buttons simultaneously again to exit energy-saving function.

Note:

- Under energy-saving function, fan speed is defaulted at auto speed and it can't be adjusted.
- Under energy-saving function, set temperature can't be adjusted. Press "TURBO" button and the remote controller won't send signal.
- Sleep function and energy-saving function can't operate at the same time. If energy-saving function has been set under cooling mode, press sleep button will cancel energy-saving function. If sleep function has been set under cooling mode, start up the energy-saving function will cancel sleep function.

2. 8 °C heating function

Under heating mode, press "TEMP" and "CLOCK" buttons simultaneously to start up or turn off 8°C heating function. When this function is started up, "⊕" and "8°C" will be shown on remote controller, and the air conditioner keep the heating status at 8°C. Press "TEMP" and "CLOCK" buttons simultaneously again to exit 8°C heating function.

Note:

- Under 8°C heating function, fan speed is defaulted at auto speed and it can't be adjusted.
- Under 8°C heating function, set temperature can't be adjusted. Press "TURBO" button and the remote controller won't send signal.
- Sleep function and 8°C heating function can't operate at the same time. If 8°C heating function has been set under cooling mode, press sleep button will cancel 8°C heating function. If sleep function has been set under cooling mode, start up the 8°C heating function will cancel sleep function.
- Under °F temperature display, the remote controller will display 46 °F heating.

3. Child lock function

Press "▲" and "▼" simultaneously to turn on or turn off child lock function. When child lock function is on, "🔒" icon is displayed on remote controller. If you operate the remote controller, the "🔒" icon will blink three times without sending signal to the unit.

4. Temperature display switchover function

Under OFF status, press "▼" and "MODE" buttons simultaneously to switch temperature display between °C and °F.

5. I FEEL Function

Press "▲" and "MODE" buttons simultaneously to start I FEEL function and "iFEEL" will be displayed on the remote controller. After this function is set, the remote controller will send the detected ambient temperature to the controller and the unit will automatically adjust the indoor temperature according to the detected temperature. Press this two buttons simultaneously again to close I FEEL function and "iFEEL" will disappear.

- Please put the remote controller near user when this function is set. Do not put the remote controller near the object of high temperature or low temperature in order to avoid detecting inaccurate ambient temperature. When I FEEL function is turned on, the remote controller should be put within the area where indoor unit can receive the signal sent by the remote controller.

If "H1" is displayed on the remote controller while it's not operated by the professional person/after-sales person, it belongs to the misoperation.

Please operate it as below to cancel it. Under the OFF status of remote controller, hold the MODE button for 5s to cancel "H1" display.

Note:

- If remote controller displays "H1", it belongs to the normal function reminder. If the unit is defrosting under heating mode, it operates according to H1 defrosting mode. "H1" won't be displayed on the panel of indoor unit;
- Once you set H1 mode, if you turn off unit by remote controller, H1 will display 3 times on the remote controller and then disappear;
- Also, when you set H1 mode, when you change to heating mode, H1 will display 3 times on the remote controller and then disappear.

Replacement of batteries in remote controller

1. Press the back side of remote controller marked with "  ", as shown in the fig, and then push out the cover of battery box along the arrow direction.
2. Replace two 7# (AAA 1.5V) dry batteries, and make sure the position of "+" polar and "-" polar are correct.
3. Reinstall the cover of battery box.

Note:

- During operation, point the remote control signal sender at the receiving window on indoor unit.
- The distance between signal sender and receiving window should be no more than 8m, and there should be no obstacles between them.
- Signal may be interfered easily in the room where there is fluorescent lamp or wireless telephone; remote controller should be close to indoor unit during operation.
- Replace new batteries of the same model when replacement is required.
- When you dont use remote controller for a long time, please take out the batteries.
- If the display on remote controller is fuzzy or theres no display, please replace batteries.

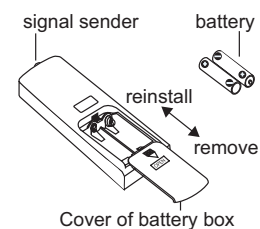

3. MODE button

Each time you press this button, a mode is selected in a sequence that goes from AUTO, COOL, DRY, FAN, and HEAT *, as the following:

AUTO ► COOL ► DRY ► FAN ► HEAT*

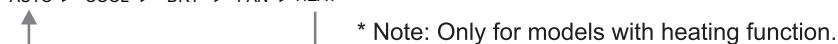

After energization, AUTO mode is defaulted. In AUTO mode, the set temperature will not be displayed on the LCD, and the unit will automatically select the suitable operation mode in accordance with the room temperature to make indoor room comfortable.

4. SWING button

Press this button to set up & down swing angle, which circularly changes as below:

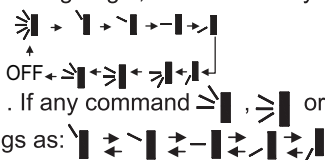

This remote controller is universal. If any command , or is sent out, the unit will carry out the command as

indicates the guide louver swings as:

5. ▼ button

Press this button to decrease set temperature. Holding it down above 2 seconds rapidly decreases set temperature. In AUTO mode, set temperature is not adjustable.

6. FAN button

This button is used for setting Fan Speed in the sequence that goes from AUTO, , , to , then back to Auto.

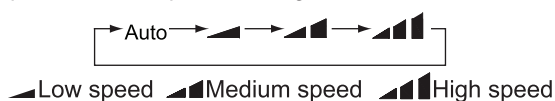

7. TIMER OFF button

Press this button to initiate the auto-off timer. To cancel the auto-timer program, simply press the button again. TIMER OFF setting is the same as TIMER ON.

8. CLOCK button

Press CLOCK button, blinking. Within 5 seconds, pressing ▲ or ▼ button adjusts the present time. Holding down either button above 2 seconds increases or decreases the time by 1 minute every 0.5 second and then by 10 minutes every 0.5 second. During blinking after setting, press CLOCK button again to confirm the setting, and then will be constantly displayed.

9. TIMER ON button

Press this button to initiate the auto-ON timer. To cancel the auto-timer program, simply press this button again. After press of this button, disappears and "ON "blinks. 0 0:00 is displayed for ON timesetting. Within 5 seconds, press ▲ or ▼ button to adjust the time value. Every press of either button changes the time setting by 1 minute. Holding down either button rapidly changes the time setting by 1 minute and then 10 minutes. Within 5 Seconds after setting, press TIMER ON button to confirm.

10. SLEEP button

Press this button to go into the SLEEP operation mode. Press it again to cancel this function. This function is available in COOL, HEAT (Only for models with heating function) to maintain the most comfortable temperature for you.

11. TEMP button

Press this button, you can see indoor set temperature, indoor ambient temperature on indoor unit's display. The setting on remote controller is selected circularly as below:

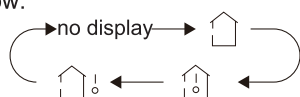

When selecting "no display" with remote controller or no display, temperature indicator on indoor unit displays set temperature; When selecting "indoor unit icon with thermometer" with remote controller, temperature indicator on indoor unit displays indoor ambient temperature; 3s later or within 3s it receives other remote controller signal that will return to display the setting temperature.



- Caution:
- This model hasn't outdoor ambient temperature display function. While remote controller can operate "indoor unit icon with thermometer" and indoor unit displays set temperature.
 - It's defaulted to display set temperature when turning on the unit.
 - Only for the models with temperature indicator on indoor unit.

12. TURBO button

Press this button to activate / deactivate the Turbo function which enables the unit to reach the preset temperature in the shortest time. In COOL mode, the unit will blow strong cooling air at super high fan speed. In HEAT mode, the unit will blow strong heating air at super high fan speed.

13. X-FAN | button

X-FAN function: In COOL or DRY mode, the icon  is displayed and the indoor fan will continue operation for 2 minutes in order to dry the indoor unit even though you have turned off the unit. After energization, X-FAN OFF is defaulted. X-FAN is not available in AUTO, FAN or HEAT mode.





 function: turn on the display's light and press this button again to turn off the display's light. If the light is turned on,  is displayed. If the light is turned off,  disappears.

14. WiFi button

Press "WiFi" button to turn on or turn off WiFi function. When WiFi function is turned on, the "WiFi" icon will be displayed on remote controller; Under status of unit off, press "MODE" and "WiFi" buttons simultaneously for 1s, WiFi module will restore to factory default setting.



- This function is only available for some models.

15. button

Press this button to achieve the on and off of healthy and scavenging functions in operation status. Press this button for the first time to start scavenging function; LCD displays "". Press the button for the second time to start healthy and scavenging functions simultaneously; LCD displays "" and "". Press this button for the third time to quit healthy and scavenging functions simultaneously. Press the button for the fourth time to start healthy function; LCD display "". Press this button again to repeat the operation above. (This function is applicable to partial of models)

Function introduction for combination buttons

Combination of "▲" and "▼" buttons: About lock

Press "▲" and "▼" buttons simultaneously to lock or unlock the keypad. If the remote controller is locked,  is displayed. In this case, pressing any button,  blinks three times.

Combination of "MODE" and "▼" buttons:

About switch between Fahrenheit and centigrade

At unit OFF, press "MODE" and "▼" buttons simultaneously to switch between °C and °F .

Combination of "TEMP" and "CLOCK" buttons:

About Energy-saving Function

Press "TEMP" and "CLOCK" simultaneously in COOL mode to start energy-saving function. Nixie tube on the remote controller displays "SE". Repeat the operation to quit the function.

Combination of "TEMP" and "CLOCK" buttons:

About 8°C Heating Function

Press "TEMP" and "CLOCK" simultaneously in HEAT mode to start 8°C Heating Function Nixie tube on the remote controller displays "8" and a selected temperature of "8°C ". (46 °F if Fahrenheit is adopted). Repeat the operation to quit the function.

I FEEL Function

Press "▲" and "MODE" buttons simultaneously to start I FEEL function and "" will be displayed on the remote controller. After this function is set, the remote controller will send the detected ambient temperature to the controller and the unit will automatically adjust the indoor temperature according to the detected temperature.

Press this two buttons simultaneously again to close I FEEL function and "" will disappear.

- Please put the remote controller near user when this function is set. Do not put the remote controller near the object of high temperature or low temperature in order to avoid detecting inaccurate ambient temperature. When I FEEL function is turned on, the remote controller should be put within the area where indoor unit can receive the signal sent by the remote controller.

"If "H1" is displayed on the remote controller while it's not operated by the professional person/after-sales person, it belongs to the misoperation.

Please operate it as below to cancel it. Under the OFF status of remote controller, hold the "MODE" button and "X-FAN" buttons simultaneously for 5s to cancel "H1" display.

Note:

- If remote controller displays "H1", it belongs to the normal function reminder. If the unit is defrosting under heating mode, it operates according to H1 defrosting mode. "H1" won't be displayed on the panel of indoor unit;
- Once you set H1 mode, if you turn off unit by remote controller, H1 will display 3 times on the remote controller and then disappear;
- Also, when you set H1 mode, when you change to heating mode, H1 will display 3 times on the remote controller and then disappear."

Replacement of batteries in remote controller

1. Press the back side of remote controller marked with "" , as show in the fig, and then push out the cover of battery box along the arrow direction.
2. Replace two 7# (AAA 1.5V) dry batteries, and make sure the position of "▲" polar and "▼" polar are correct.
3. Reinstall the cover of battery box.

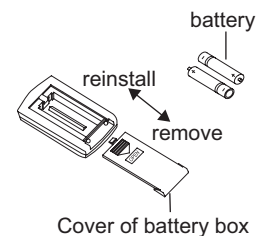

Note:

- During operation, point the remote control signal sender at the receiving window on indoor unit.
- The distance between signal sender and receiving window should be no more than 8m, and there should be no obstacles between them.
- Signal may be interfered easily in the room where there is fluorescent lamp or wireless telephone; remote controller should be close to indoor unit during operation.
- Replace new batteries of the same model when replacement is required.
- When you don't use remote controller for a long time, please take out the batteries.
- If the display on remote controller is fuzzy or there's no display, please replace batteries.

6.4 Ewpe Smart App Operation Manual

Control Flow Chart

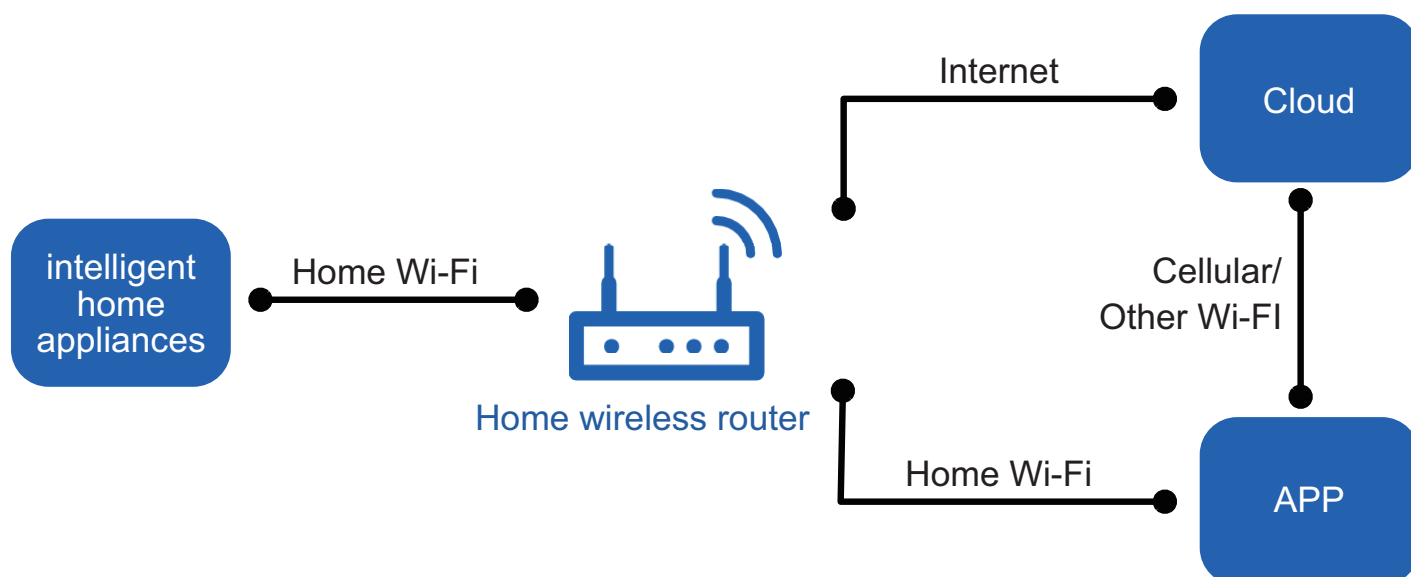

Operating Systems

Requirement for User's smart phone:

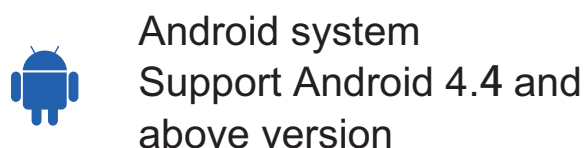
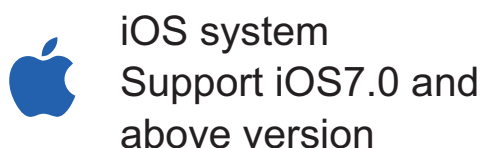

Download and installation



App Download Linkage

Scan the QR code or search "Ewpe Smart" in the application market to download and install it. When "Ewpe Smart" App is installed, register the account and add the device to achieve long-distance control and LAN control of smart home appliances. For more information, please refer to "Help" in App.

6.5 Brief Description of Modes and Functions

1. Temperature Parameters

Indoor preset temperature(T_{preset})

Indoor ambient temperature ($T_{\text{amb.}}$)

2. Basic Functions

Once energized, in no case should the compressor be restarted within less than 3 minutes. In the situation that memory function is available, for the first energization, if the compressor is at stop before de-energization, the compressor will be started without a 3-minute lag; if the compressor is in operation before de-energization, the compressor will be started with a 3-minute lag; and once started, the compressor will not be stopped within 6 minutes regardless of changes in room temperature;

(1) Cooling Mode

① Working conditions and process of cooling

When $T_{\text{amb.}} \geq T_{\text{preset}}$, the unit will enter cooling operation, in which case the indoor fan, the outdoor fan and the compressor will work and the indoor fan will run at preset speed.

When $T_{\text{amb.}} \leq T_{\text{preset}} + 28.4^\circ\text{F}$, the compressor will stop, the outdoor fan will stop with a time lag of 60s, and the indoor fan will run at preset speed.

When $T_{\text{preset}} + 28.4^\circ\text{F} < T_{\text{amb.}} < T_{\text{preset}}$, the unit will remain at its previous state.

Under this mode, the four-way valve will be de-energized and temperature can be set within a range from $61^\circ\text{F} \sim 86^\circ\text{F}$. If the compressor is shut down for some reason, the indoor fan and the swing device will operate at original state.

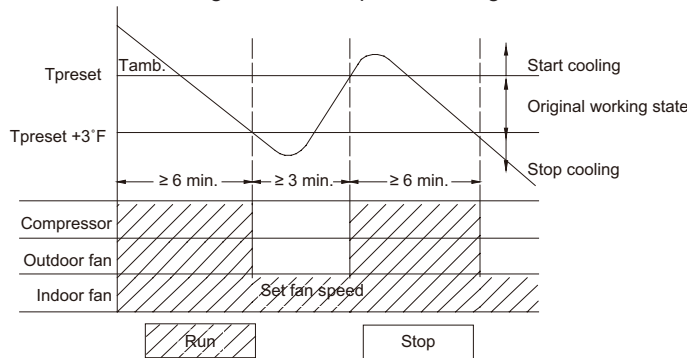

② Protection

Antifreeze protection

Under cooling and dehumidifying mode, 6 minutes after the compressor is started:

If $T_{\text{evap}} \leq 35.6^\circ\text{F}$, the compressor will operate at reduced frequency.

If $T_{\text{evap}} \leq 30.2^\circ\text{F}$ is detected for durative 3 minutes, the compressor will stop, and after 60 seconds, the outdoor fan will stop; and under cooling mode, the indoor fan and the swing motor will remain at the original state.

If $T_{\text{evap}} \geq 42.8^\circ\text{F}$ and the compressor has remained at OFF for at least 3 minutes, the compressor will resume its original operation state.

Total current up and frequency down protection

If $I_{\text{total}} \leq 16\text{A}$, frequency rise will be allowed; if $I_{\text{total}} \geq 17\text{A}$, frequency rise will not be allowed; if $I_{\text{total}} \geq 18\text{A}$, the compressor will run at reduced frequency; and if $I_{\text{total}} \geq 20\text{A}$, the compressor will stop and the outdoor fan will stop with a time lag of 60s.

(2) Dehumidifying Mode

① Working conditions and process of dehumidifying

If $T_{\text{amb.}} > T_{\text{preset}}$, the unit will enter cooling and dehumidifying mode, in which case the compressor and the outdoor fan will operate and the indoor fan will run at low speed.

If $T_{\text{preset}} + 28.4^\circ\text{F} \leq T_{\text{amb.}} \leq T_{\text{preset}}$ the compressor remains at its original operation state.

If $T_{\text{amb.}} < T_{\text{preset}}$, the compressor will stop, the outdoor fan will stop with a time lag of 60s, and the indoor fan will operate at low speed.

② Protection

Protection is the same as that under the cooling mode.

(3) Heating Mode

① Working conditions and process of heating

If $T_{\text{amb.}} \leq T_{\text{preset}} + 35.6^\circ\text{F}$ ($T_{\text{indoor ambient}} \leq T_{\text{setting}} + 2^\circ\text{C}$, start with heating mode), the unit enters heating mode, in which case the four-way valve, the compressor and the outdoor fan will operate simultaneously, and the indoor fan will run at preset speed in the condition of preset cold air prevention.

If $T_{\text{amb.}} \geq T_{\text{preset}} + 37.4^\circ\text{F}$ ($T_{\text{indoor ambient}} \geq T_{\text{setting}} + 3^\circ\text{C}$, it stops when reaches temperature point), the compressor will stop, the outdoor fan will stop with a time lag of 60s, and the indoor fan will stop after 60-second blow at low speed.

If $T_{\text{preset}} < T_{\text{amb.}} < T_{\text{preset}} + 37.4^\circ\text{F}$ ($T_{\text{setting}} < T_{\text{indoor ambient}} < T_{\text{setting}} + 3^\circ\text{C}$, maintain heating mode), the unit will maintain its original operating status.

Under this mode, the four-way valve is energized and temperature can be set within a range of $61^\circ\text{F} \sim 86^\circ\text{F}$. The operating symbol, the heating symbol and preset temperature are revealed on the display.

② Condition and process of defrost

When duration of successive heating operation is more than 45 minutes, or accumulated heating time more than 90 minutes, and one of the following conditions is reached, the unit will enter the defrost mode after 3 minutes.

- a. Toutdoor amb. $\geq 41^{\circ}\text{F}$, Toutdoor pipe $\leq 28.4^{\circ}\text{F}$;
- b. $28.4^{\circ}\text{F} \leq \text{Toutdoor amb.} \leq 41^{\circ}\text{F}$, Toutdoor pipe - Tcompensation $\leq 23^{\circ}\text{F}$
- c. $23^{\circ}\text{F} < \text{Toutdoor amb.} \leq 28.4^{\circ}\text{F}$, Toutdoor pipe - Tcompensation $\leq 17.6^{\circ}\text{F}$;
- d. $14^{\circ}\text{F} < \text{Toutdoor amb.} < 23^{\circ}\text{F}$, Toutdoor pipe - Tcompensation $\leq \text{Toutdoor amb.} + 26.6^{\circ}\text{F}$;
- e. Toutdoor amb. $< 14^{\circ}\text{F}$, Toutdoor pipe - Tcompensation $\leq \text{Toutdoor amb.} + 26.6^{\circ}\text{F}$;

After energization, when defrosting for the first time Tcompensation = 0°F . If it is not the firstly time for defrosting, the Tcompensation is determined by the Toutdoor pipe of last time quitting defrosting.

- a. Toutdoor pipe $> 35.6^{\circ}\text{F}$, Tcompensation = 32°F ;
- b. Toutdoor pipe $\leq 35.6^{\circ}\text{F}$, Tcompensation = 33.8°F .

At that time, the indoor fan stops and the compressor stops, and after 60 seconds the outer fan will stop, and then after 30 seconds, the four-way valve will stop. After 30 seconds, the compressor is initiated for raising the frequency to defrost frequency.

When the compressor has operated under defrost mode for 10 minutes, or Touter tube $\geq 50^{\circ}\text{F}$, the compressor will be converted to 46Hz operation. After 30 seconds, the compressor will stop. And after another 30 seconds, the four-way valve will be opened, and after 60 seconds, the compressor and the outer fan will be started, the indoor fan will run under preset cold air prevention conditions, and H1 will be displayed at temperature display area on the display panel. Defrost frequency is 70 Hz.

3. Protection

Cold air prevention

The unit is started under heating mode (the compressor is ON):

① In the case of Tindoor amb. $< 75^{\circ}\text{F}$: if T tube $\leq 104^{\circ}\text{F}$ and the indoor fan is at stop state, the indoor fan will begin to run at low speed with a time lag of 2 minutes. Within 2 minutes, if T tube $> 104^{\circ}\text{F}$, the indoor fan also will run at low speed; and after 1 minute operation at low speed, the indoor fan will be converted to operation at preset speed. Within 1 minute low speed operation or 2 minute non-operation, if T tube $> 108^{\circ}\text{F}$, the fan will run at present speed.

② In the case of Tindoor amb. $< 75^{\circ}\text{F}$: if T tube $\leq 108^{\circ}\text{F}$, the indoor fan will run at low speed, and after one minute, the indoor fan will be converted to preset speed. Within 1 minute low speed operation, if T tube $> 104^{\circ}\text{F}$, the indoor fan will be converted to preset speed. Note: Tindoor amb. indicated in ① and ② refers to, under initially heating mode, the indoor ambient temperature before the command to start the compressor is performed according to the program, or after the unit is withdrawn from defrost, the indoor ambient temperature before the defrost symbol is cleared.

Total current up and frequency down protection

If the total current $I_{\text{total}} \leq 16\text{A}$, frequency rise will be allowed; if $I_{\text{total}} \geq 17\text{A}$, frequency rise will not be allowed; if $I_{\text{total}} \geq 18\text{A}$, the compressor will run at reduced frequency; and if $I_{\text{total}} \geq 20\text{A}$, the compressor will stop and the outdoor fan will stop with a time lag of 60s.

(4) Fan Mode

Under the mode, the indoor fan will run at preset speed and the compressor, the outdoor fan, the four-way valve and the electric heater will stop.

Under the mode, temperature can be set within a range of $61^{\circ}\text{F} \sim 86^{\circ}\text{F}$.

(5) AUTO Mode

① Working conditions and process of AUTO mode

Under AUTO mode, standard cooling temperature Tpreset is 77°F and standard heating temperature Tpreset is 68°F .

a. Once energized, if Tamb. $\leq 71.6^{\circ}\text{F}$, the unit will be started under heating mode; if $71.6^{\circ}\text{F} < \text{Tamb.} < 78.8^{\circ}\text{F}$, the unit will run under fan mode and the run indicator will be bright; and if Tamb. $\geq 78.8^{\circ}\text{F}$, the unit will be started under cooling mode.

b. Under AUTO mode, if Tamb. $\geq \text{Tpreset} + 1.8^{\circ}\text{F}$ is detected, the unit will select to run under cooling mode, in which case implicit preset temperature is 77°F ; if Tamb. $\leq \text{Tpreset} - 1.8^{\circ}\text{F}$, the compressor will stop, the outdoor fan will stop with a time lag of 1 minute, and the indoor fan will run at preset speed; and if $\text{Tpreset} - 1.8^{\circ}\text{F} < \text{Tamb.} < \text{Tpreset} + 1.8^{\circ}\text{F}$, the unit will remain at its original state.

c. Under AUTO mode, if Tamb. $\leq \text{Tpreset} + 3.6^{\circ}\text{F}$ is detected, the unit will select to run under heating mode, in which case implicit preset temperature is 64°F ; if Tamb. $\geq \text{Tpreset} + 9^{\circ}\text{F}$, the compressor will stop, the outdoor fan will stop with a time lag of 1 minute, and the indoor fan will run under the mode of residue heat blowing; and if $\text{Tpreset} + 3.6^{\circ}\text{F} < \text{Tamb.} < \text{Tpreset} + 41^{\circ}\text{F}$, the unit will remain at its original state. The cooling-only unit will run under fan mode.

d. Under AUTO mode, if $71.6^{\circ}\text{F} < \text{Tamb.} < 78.8^{\circ}\text{F}$, the unit will remain at its original state.

② Protection

a. In cooling operation, protection is the same as that under the cooling mode;

b. In heating operation, protection is the same as that under the heating mode;

c. When ambient temperature changes, operation mode will be converted preferentially. Once started, the compressor will remain unchanged for at least 6 minutes.

(6) Common Protection Functions and Fault Display under COOL, HEAT, DRY and AUTO Modes

① Overload protection

Ttube: measured temperature of outdoor heat exchanger under cooling mode; and measured temperature of indoor heat exchanger under heating mode.

1) Cooling overload

a. If Ttube $\leq 126^{\circ}\text{F}$, the unit will return to its original operation state.

b. If Ttube $\geq 131^{\circ}\text{F}$, frequency rise is not allowed.

- c. If $T_{tube} \geq 136^{\circ}\text{F}$, the compressor will run at reduced frequency.
 - d. If $T_{tube} \geq 144^{\circ}\text{F}$, the compressor will stop and the indoor fan will run at preset speed.
- 2) Heating overload
- a. If $T_{tube} \leq 126^{\circ}\text{F}$, the unit will return to its original operation state.
 - b. If $T_{tube} \geq 131^{\circ}\text{F}$, frequency rise is not allowed.
 - c. If $T_{tube} \geq 136^{\circ}\text{F}$, the compressor will run at reduced frequency.
 - d. If $T_{tube} \geq 144^{\circ}\text{F}$, the compressor will stop and the indoor fan will blow residue heat and then stop.

② Exhaust temperature protection of compressor

If exhaust temperature $\geq 208^{\circ}\text{F}$, frequency is not allowed to rise.

If exhaust temperature $\geq 217^{\circ}\text{F}$, the compressor will run at reduced frequency.

If exhaust temperature $\geq 230^{\circ}\text{F}$, the compressor will stop.

If exhaust temperature $\leq 194^{\circ}\text{F}$, the compressor has stayed at stop for at least 3 minutes, the compressor will resume its operation.

③ Communication fault

If the unit fails to receive correct signals for durative 3 minutes, communication fault can be justified and the whole system will stop.

④ Module protection

Under module protection mode, the compressor will stop. When the compressor remains at stop for at least 3 minutes, the compressor will resume its operation. If module protection occurs six times in succession, the compressor will not be started again.

⑤ Overload protection

If temperature sensed by the overload sensor is over 239°F , the compressor will stop and the outdoor fan will stop with a time lag of 30 seconds. If temperature is below 203°F , the overload protection will be relieved.

If voltage on the DC bus is below 150V or over 420V, the compressor will stop and the outdoor fan will stop with a time lag of 30 seconds. When voltage on the DC bus returns to its normal value and the compressor has stayed at stop for at least 3 minutes, the compressor will resume its operation.

⑥ Faults of temperature sensors

Designation of sensors	Faults
Indoor ambient temperature	The sensor is detected to be open-circuited or short-circuited for successive 5 seconds
Indoor tube temperature	The sensor is detected to be open-circuited or short-circuited for successive 5 seconds
Outdoor ambient temperature	The sensor is detected to be open-circuited or short-circuited for successive 30 seconds
Outdoor tube temperature	The sensor is detected to be open-circuited or short-circuited for successive 30 seconds, and no detection is performed within 10 minutes after defrost begins.
Exhaust	After the compressor has operated for 3 minutes, the sensor is detected to be open-circuited or short-circuited for successive 30 seconds.
Overload	After the compressor has operated for 3 minutes, the sensor is detected to be open-circuited or short-circuited for successive 30 seconds.

Part II : Installation and Maintenance

7. Notes for Installation and Maintenance

Safety Precautions: Important!

Please read the safety precautions carefully before installation and maintenance.
The following contents are very important for installation and maintenance.

Please follow the instructions below.

- The installation or maintenance must accord with the instructions.
- Comply with all national electrical codes and local electrical codes.
- Pay attention to the warnings and cautions in this manual.
- All installation and maintenance shall be performed by distributor or qualified person.
- All electric work must be performed by a licensed technician according to local regulations and the instructions given in this manual.
- Be caution during installation and maintenance. Prohibit incorrect operation to prevent electric shock, casualty and other accidents.



Warnings

Electrical Safety Precautions:

1. Cut off the power supply of air conditioner before checking and maintenance.
2. The air condition must apply specialized circuit and prohibit share the same circuit with other appliances.
3. The air conditioner should be installed in suitable location and ensure the power plug is touchable.
4. Make sure each wiring terminal is connected firmly during installation and maintenance.
5. Have the unit adequately grounded. The grounding wire cant be used for other purposes.
6. Must apply protective accessories such as protective boards, cable-cross loop and wire clip.
7. The live wire, neutral wire and grounding wire of power supply must be corresponding to the live wire, neutral wire and grounding wire of the air conditioner.
8. The power cord and power connection wires cant be pressed by hard objects.
9. If power cord or connection wire is broken, it must be replaced by a qualified person.

10. If the power cord or connection wire is not long enough, please get the specialized power cord or connection wire from the manufacture or distributor. Prohibit prolong the wire by yourself.
11. For the air conditioner without plug, an air switch must be installed in the circuit. The air switch should be all-pole parting and the contact parting distance should be more than 1/8 inch.
12. Make sure all wires and pipes are connected properly and the valves are opened before energizing.
13. Check if there is electric leakage on the unit body. If yes, please eliminate the electric leakage.
14. Replace the fuse with a new one of the same specification if it is burnt down; dont replace it with a cooper wire or conducting wire.
15. If the unit is to be installed in a humid place, the circuit breaker must be installed.

Installation Safety Precautions:

1. Select the installation location according to the requirement of this manual.(See the requirements in installation part)
2. Handle unit transportation with care; the unit should not be carried by only one person if it is more than 44.09lb.
3. When installing the indoor unit and outdoor unit, a sufficient fixing bolt must be installed; make sure the installation support is firm.
4. Ware safety belt if the height of working is above 78 3/4 inch.
5. Use equipped components or appointed components during installation.
6. Make sure no foreign objects are left in the unit after finishing installation.

Refrigerant Safety Precautions:

When refrigerant leaks or requires discharge during installation, maintenance, or disassembly, it should be handled by certified professionals or otherwise in compliance with local laws and regulations.

1. Avoid contact between refrigerant and fire as it generates poisonous gas; Prohibit prolong the connection pipe by welding.
2. Apply specified refrigerant only. Never have it mixed with any other refrigerant. Never have air remain in the refrigerant line as it may lead to rupture or other hazards.
3. Make sure no refrigerant gas is leaking out when installation is completed.
4. If there is refrigerant leakage, please take sufficient measure to minimize the density of refrigerant.
5. Never touch the refrigerant piping or compressor without wearing glove to avoid scald or frostbite.

Improper installation may lead to fire hazard, explosion, electric shock or injury.

Main Tools for Installation and Maintenance

<p>1. Level meter, measuring tape</p> 	<p>2. Screw driver</p> 	<p>3. Impact drill, drill head, electric drill</p> 
<p>4. Electroprobe</p> 	<p>5. Universal meter</p> 	<p>6. Torque wrench, open-end wrench, inner hexagon spanner</p> 
<p>7. Electronic leakage detector</p> 	<p>8. Vacuum pump</p> 	<p>9. Pressure meter</p> 
<p>10. Pipe pliers, pipe cutter</p> 	<p>11. Pipe expander, pipe bender</p> 	<p>12. Soldering appliance, refrigerant container electronic scale</p> 

8. Installation

8.1 Installation Dimension Diagram

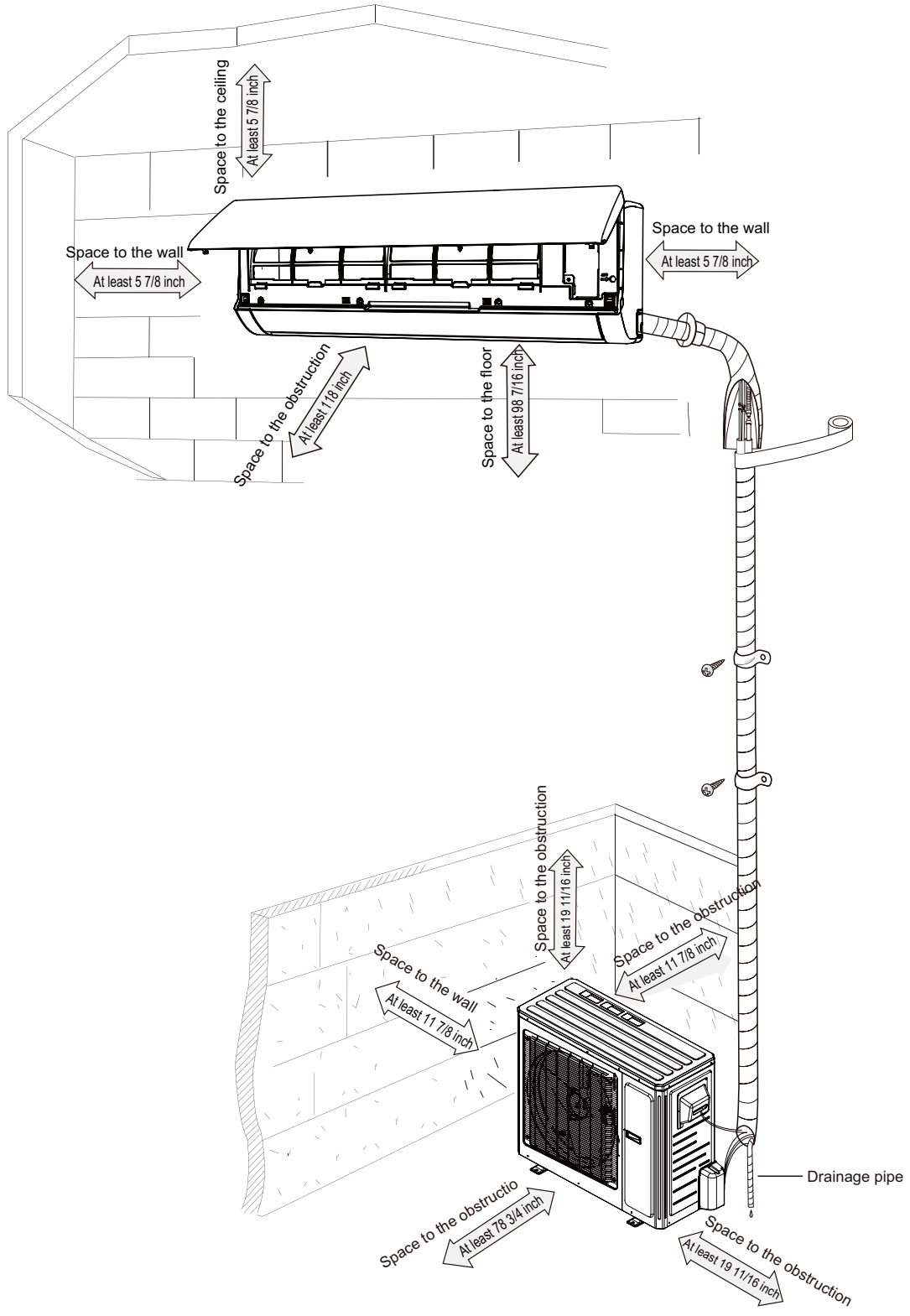

Installation procedures

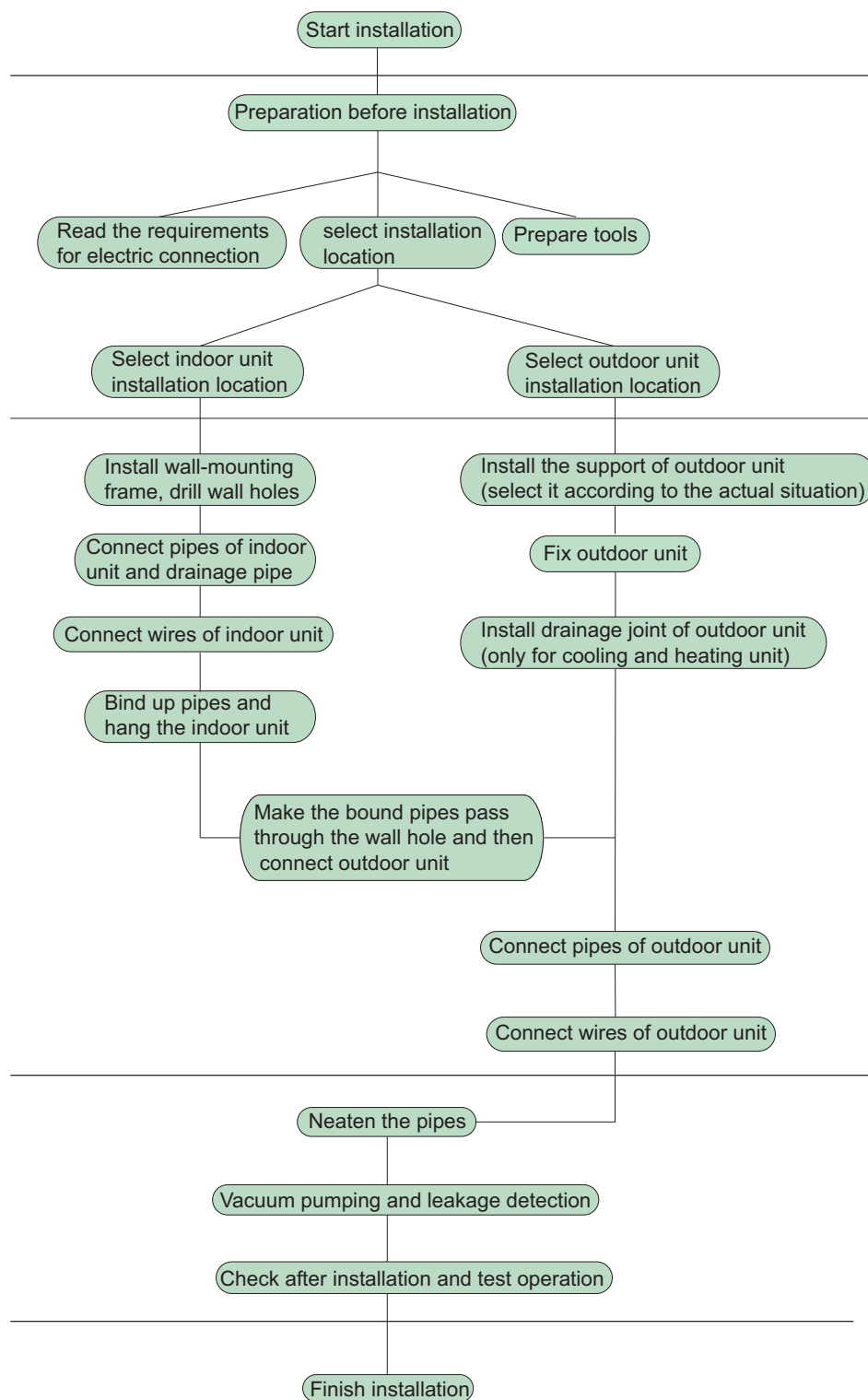

Note: this flow is only for reference; please find the more detailed installation steps in this section.

8.2 Installation Parts-checking

No.	Name	No.	Name
1	Indoor unit	8	Sealing gum
2	Outdoor unit	9	Wrapping tape
3	Connection pipe	10	Support of outdoor unit
4	Drainage pipe	11	Fixing screw
5	Wall-mounting frame	12	Drainage plug(cooling and heating unit)
6	Connecting cable(power cord)	13	Owners manual, remote controller
7	Wall pipe		

⚠ Note:

- 1.Please contact the local agent for installation.
- 2.Dont use unqualified power cord.

8.3 Selection of Installation Location

1. Basic Requirement:

Installing the unit in the following places may cause malfunction. If it is unavoidable, please consult the local dealer:

- (1) The place with strong heat sources, vapors, flammable or explosive gas, or volatile objects spread in the air.
- (2) The place with high-frequency devices (such as welding machine, medical equipment).
- (3) The place near coast area.
- (4) The place with oil or fumes in the air.
- (5) The place with sulfureted gas.
- (6) Other places with special circumstances.
- (7) Do not use the unit in the immediate surroundings of a laundry a bath a shower or a swimming pool.

2. Indoor Unit:

- (1) There should be no obstruction near air inlet and air outlet.
- (2) Select a location where the condensation water can be dispersed easily and wont affect other people.
- (3) Select a location which is convenient to connect the outdoor unit and near the power socket.
- (4) Select a location which is out of reach for children.
- (5) The location should be able to withstand the weight of indoor unit and wont increase noise and vibration.
- (6) The appliance must be installed 98 7/16 inch above floor.
- (7) Dont install the indoor unit right above the electric appliance.
- (8) The appliance shall not be installed in the laundry.

3. Outdoor Unit:

- (1) Select a location where the noise and outflow air emitted by the outdoor unit will not affect neighborhood.
- (2) The location should be well ventilated and dry, in which the outdoor unit wont be exposed directly to sunlight or strong wind.
- (3) The location should be able to withstand the weight of outdoor unit.
- (4) Make sure that the installation follows the requirement of installation dimension diagram.
- (5)Select a location which is out of reach for children and far away from animals or plants.If it is unavoidable, please add fence for safety purpose.

8.4 Requirements for electric connection

1. Safety Precaution

- (1) Must follow the electric safety regulations when installing the unit.
- (2) According to the local safety regulations, use qualified power supply circuit and air switch.
- (3) Make sure the power supply matches with the requirement of air conditioner. Unstable power supply or incorrect wiring may result in electric shock,fire hazard or malfunction. Please install proper power supply cables before using the air conditioner.

Air-conditioner	Air switch capacity
30K except VIRU30HP230V1A	30A
VIRU30HP230V1A	50A
36K except VIRU36HP230V1A	40A
VIRU36HP230V1A	50A

- (4) Properly connect the live wire, neutral wire and grounding wire of power socket.
- (5) Be sure to cut off the power supply before proceeding any work related to electricity and safety.
- (6) Do not put through the power before finishing installation.
- (7) If the supply cord is damaged,it must be replaced by the manufacturer,its service agent or similarly qualified persons in order to avoid a hazard.
- (8) The temperature of refrigerant circuit will be high, please keep the interconnection cable away from the copper tube.
- (9) The appliance shall be installed in accordance with national wiring regulations.
- (10)Installation must be performed in accordance with the requirement of NEC and CEC by authorized personnel only.

2. Grounding Requirement:

- (1) The air conditioner is first class electric appliance. It must be properly grounding with specialized grounding device by a professional. Please make sure it is always grounded effectively, otherwise it may cause electric shock.
- (2) The yellow-green wire in air conditioner is grounding wire, which cant be used for other purposes.
- (3) The grounding resistance should comply with national electric safety regulations.
- (4) The appliance must be positioned so that the plug is accessible.
- (5) An all-pole disconnection switch having a contact separation of at least 1/8 inch in all poles should be connected in fixed wiring.
- (6) Including an air switch with suitable capacity, please note the following table. Air switch should be included magnet buckle and heating buckle function, it can protect the circuit-short and overload. (Caution: please do not use the fuse only for protect the circuit)

8.5 Installation of Indoor Unit

1. Choosing Installation location

Recommend the installation location to the client and then confirm it with the client.

2. Install Wall-mounting Frame

- (1) Hang the wall-mounting frame on the wall; adjust it in horizontal position with the level meter and then point out the screw fixing holes on the wall.
- (2) Drill the screw fixing holes on the wall with impact drill (the specification of drill head should be the same as the plastic expansion particle) and then fill the plastic expansion particles

in the holes.

(3) Fix the wall-mounting frame on the wall with tapping screws and then check if the frame is firmly installed by pulling the frame. If the plastic expansion particle is loose, please drill another fixing hole nearby.

3. Install Wall-mounting Frame

(1) Choose the position of piping hole according to the direction of outlet pipe. The position of piping hole should be a little lower than the wall-mounted frame. (As show in Fig.1)

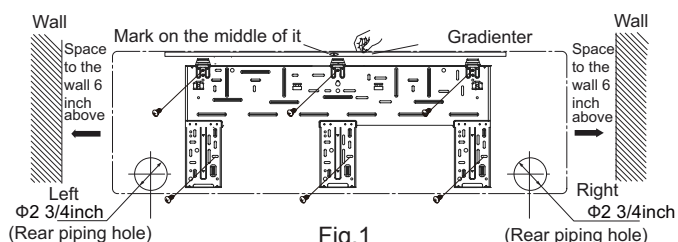

(2) Open a piping hole with the diameter of Φ2 3/4inch on the selected outlet pipe position. In order to drain smoothly, slant the piping hole on the wall slightly downward to the outdoor side with the gradient of 5-10°. (As show in Fig.2)

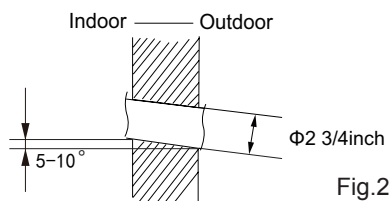

⚠ Note:

(1) Pay attention to dust prevention and take relevant safety measures when opening the hole.

4. Outlet Pipe

(1) The pipe can be led out in the direction of right, rear right, left or rear left. (As show in Fig.3)

(2) When selecting leading out the pipe from left or right, please cut off the corresponding hole on the bottom case. (As show in Fig.4)

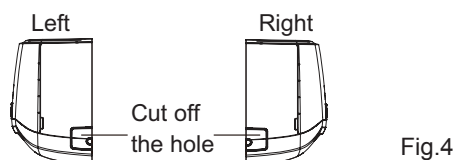
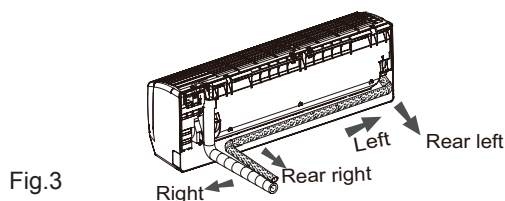

5. Connect the Pipe of Indoor Unit

(1) Aim the pipe joint at the corresponding bellmouth. (As show in Fig.5)

(2) Pretightening the union nut with hand.

(3) Adjust the torque force by referring to the following sheet. Place the open-end wrench on the pipe joint and place the torque wrench on the union nut. Tighten the union nut with

torque wrench. (As show in Fig.6)

(4) Wrap the indoor pipe and joint of connection pipe with insulating pipe, and then wrap it with tape. (As show in Fig.7)

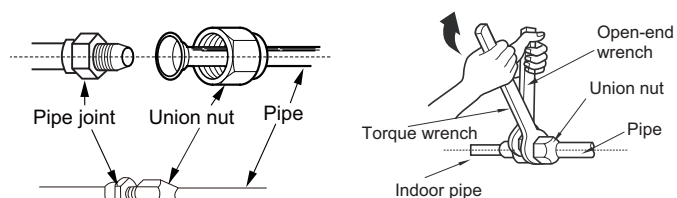

Fig.5

Fig.6

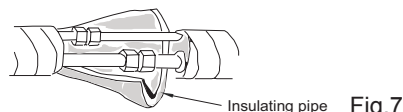

Fig.7

Refer to the following table for wrench moment of force:

Hex nut diameter(inch)	Tightening torque(ft.lbf)
Φ1/4	11.10~14.75
Φ3/8	20.12~29.50
Φ1/2	33.19~40.56
Φ5/8	44.24~47.94
Φ3/4	51.32~55.31

6. Install Drain Hose

(1) Connect the drain hose to the outlet pipe of indoor unit. (As show in Fig.8)

(2) Bind the joint with tape. (As show in Fig.9)

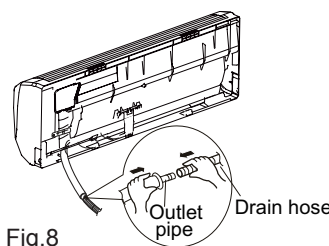

Fig.8

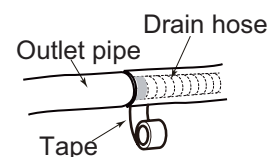

Fig.9

⚠ Note:

(1) Add insulating pipe in the indoor drain hose in order to prevent condensation.

(2) The plastic expansion particles are not provided.

(As show in Fig.10)

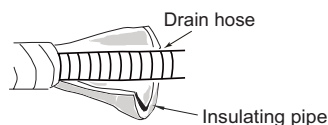

Fig.10

7. Connect Wire of Indoor Unit

(1) Open the panel, remove the screw on the wiring cover and then take down the cover. (As show in Fig.11)

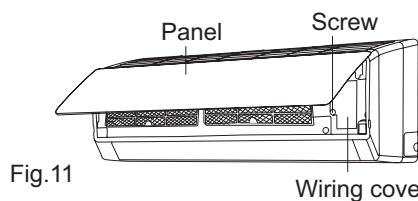

Fig.11

Wiring cover

(2) Fix the wire crossing board on connection wire sleeve at the bottom case; let the connection wire sleeve go through the wire crossing hole at the back of indoor unit, and then pull it out from the front.(As show in Fig.12)

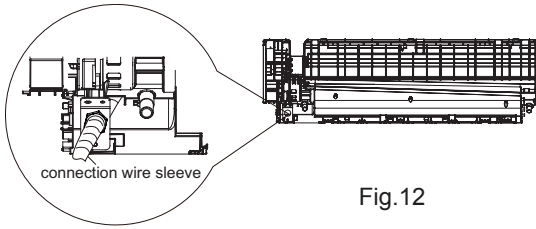

Fig.12

(3) Remove the wire clip; connect the power connection wire to the wiring terminal according to the color; tighten the screw and then fix the power connection wire with wire clip.(As show in Fig.13)

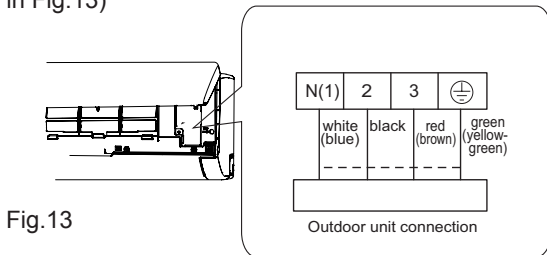
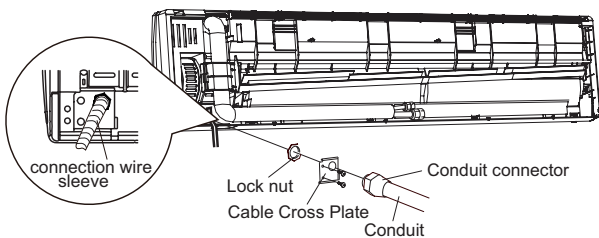

Fig.13

Note: the wiring board is for reference only, please refer to the actual one.

- (4) Put wiring cover back and then tighten the screw.
- (5) Close the panel.
- (6) Install the Conduit assy.
 - a. Fix the conduit assy on the conduit board and then let the connection wire between indoor unit and outdoor unit go through the conduit.
 - b. Fix the conduit assy on the chassis with 3 screws.
 - Conduit assy consists of conduit, conduit connector and lock nut.(Not the standard part, which should be purchased by customer.)
 - The length of conduit can be calculated according to the length of connection wire.



⚠ Note:

- (1) All wires of indoor unit and outdoor unit should be connected by a professional.
- (2) If the length of power connection wire is insufficient, please contact the supplier for a new one. Avoid extending the wire by yourself.
- (3) For the air conditioner with plug, the plug should be reachable after finishing installation.
- (4) For the air conditioner without plug, an air switch must be installed in the line. The air switch should be all-pole parting and the contact parting distance should be more than 1/8inch.

8. Bind up Pipe

- (1) Bind up the connection pipe, power cord and drain hose with the band.(As show in Fig.14)
- (2) Reserve a certain length of drain hose and power cord for installation when binding to a certain degree, separate the indoor power and then separate the drain hose.(As show in Fig.15)
- (3) Bind them evenly.
- (4) The liquid pipe and gas pipe should be bound separately at the end.

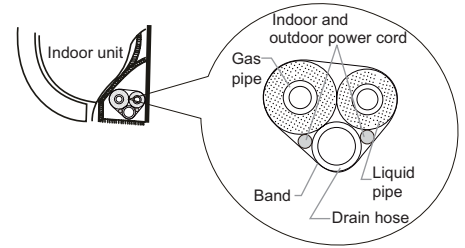

Fig.14

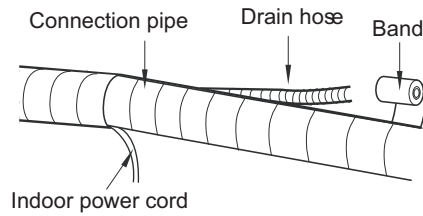

Fig.15

⚠ Note:

- (1) The power cord and control wire cant be crossed or winding.
- (2) The drain hose should be bound at the bottom.

9. Hang the Indoor Unit

- (1) Put the bound pipes in the wall pipe and then make them pass through the wall hole.
- (2) Hang the indoor unit on the wall-mounting frame.
- (3) Stuff the gap between pipes and wall hole with sealing gum.
- (4) Fix the wall pipe.(As show in Fig.16)
- (5) Check if the indoor unit is installed firmly and closed to the wall.(As show in Fig.17)

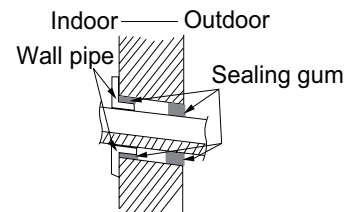

Fig.16

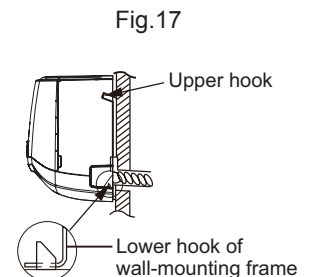

Fig.17

⚠ Note:

Do not bend the drain hose too excessively in order to prevent blocking.

8.6 Installation of Outdoor Unit

1. Fix the Support of Outdoor Unit(Select it according to the actual installation situation)

- (1) Select installation location according to the house structure.
- (2) Fix the support of outdoor unit on the selected location with expansion screws.

⚠ Note:

- (1) Take sufficient protective measures when installing the outdoor unit.
- (2) Make sure the support can withstand at least four times the unit weight.
- (3) The outdoor unit should be installed at least 1 11/64 inch above the floor in order to install drain joint.(As show in Fig.18)
- (4) For the unit with cooling capacity of 2300W~5000W, 6 expansion screws are needed; for the unit with cooling capacity of 6000W~8000W, 8 expansion screws are needed; for the unit with cooling capacity of 10000W~16000W, 10 expansion screws are needed.

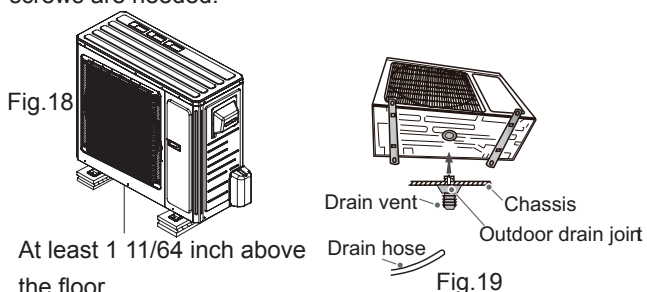

2. Install Drain Joint(Only for cooling and heating unit)

- (1) Connect the outdoor drain joint into the hole on the chassis.
 - (2) Connect the drain hose into the drain vent.
- (As show in Fig.19)

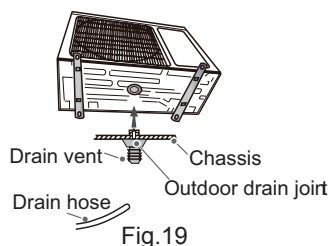

3. Fix Outdoor Unit

- (1) Place the outdoor unit on the support.
 - (2) Fix the foot holes of outdoor unit with bolts.
- (As show in Fig.20)

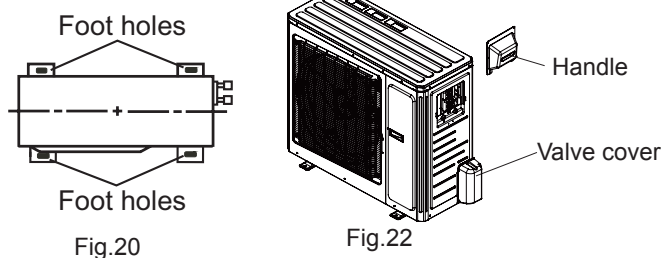

4. Connect Indoor and Outdoor Pipes

- (1) Remove the screw cap of valve and aim the pipe joint at the bellmouth of pipe.(As show in Fig.21)
- (2) Pretightening the union nut with hand..(As show in Fig.22)

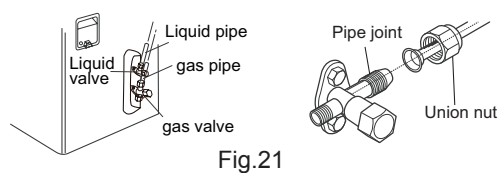

- (3) Tighten the union nut with torque wrench by referring to the sheet below.

Hex nut diameter(inch)	Tightening torque(ft-lbf)
Φ1/4	11.10~14.75
Φ3/8	20.12~29.50
Φ1/2	33.19~40.56
Φ5/8	44.24~47.94
Φ3/4	51.32~55.31

5. Connect Outdoor Electric Wire

- (1) Remove the handle from the outdoor unit.
 - (2) Fasten the power supply cord and the connection cord to the retaining plate using the lock nut.(open the knock out holes if necessary)
 - (3) Connect the power supply cord and the connection cord to terminal.
 - (4) Fasten the power supply cord and connection cord with cord clamp.
 - (5) Install the handle.
- The screws are packed with the terminal board.
- (6) Fix the power connection wire and signal control wire with wire clip (only for cooling and heating unit).

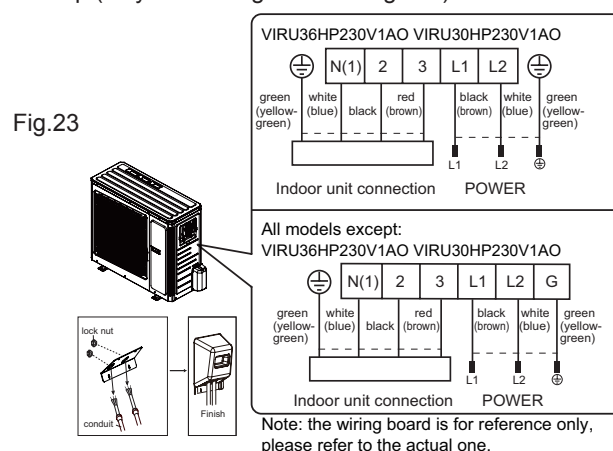

⚠ Note:

- (1) After tightening the screw, pull the power cord slightly to check if it is firm.
- (2) Never cut the power connection wire to prolong or shorten the distance.

6. Neaten the Pipes

- (1) The pipes should be placed along the wall, bent reasonably and hidden possibly. Min. semidiameter of bending the pipe is 4 inch.
- (2) If the outdoor unit is higher than the wall hole, you must set a U-shaped curve in the pipe before pipe goes into the room, in order to prevent rain from getting into the room.(As show in Fig.24)

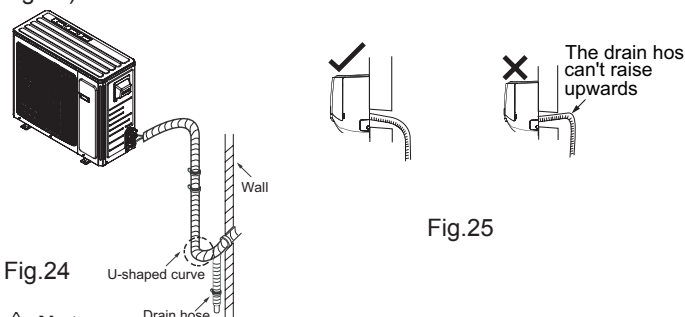

⚠ Note:

- (1) The through-wall height of drain hose shouldnt be higher than the outlet pipe hole of indoor unit.(As show in Fig.25)
- (2) Slant the drain hose slightly downwards. The drain hose cant be curved, raised and fluctuant, etc.(As show in Fig.26)

(3) The water outlet can't be placed in water in order to drain smoothly.(As show in Fig.27)

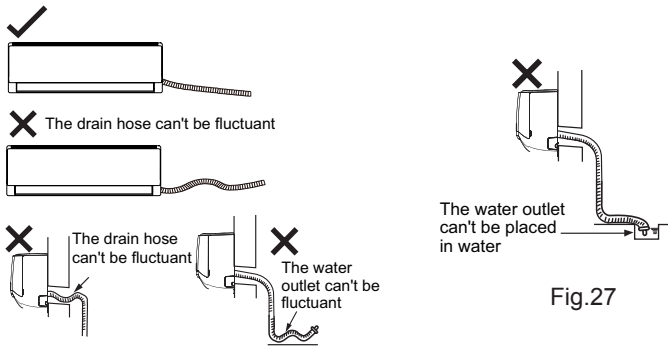

Fig.26

Fig.27

8.7 Vacuum Pumping and Leak Detection

1. Use Vacuum Pump

- (1) Remove the valve caps on the liquid valve and gas valve and the nut of refrigerant charging vent.
- (2) Connect the charging hose of piezometer to the refrigerant charging vent of gas valve and then connect the other charging hose to the vacuum pump.
- (3) Open the piezometer completely and operate for 10-15min to check if the pressure of piezometer remains in -0.1MPa.
- (4) Close the vacuum pump and maintain this status for 1-2min to check if the pressure of piezometer remains in -0.1MPa. If the pressure decreases, there may be leakage.
- (5) Remove the piezometer, open the valve core of liquid valve and gas valve completely with inner hexagon spanner.
- (6) Tighten the screw caps of valves and refrigerant charging vent.(As show in Fig.28)
- (7) Reinstall the handle.

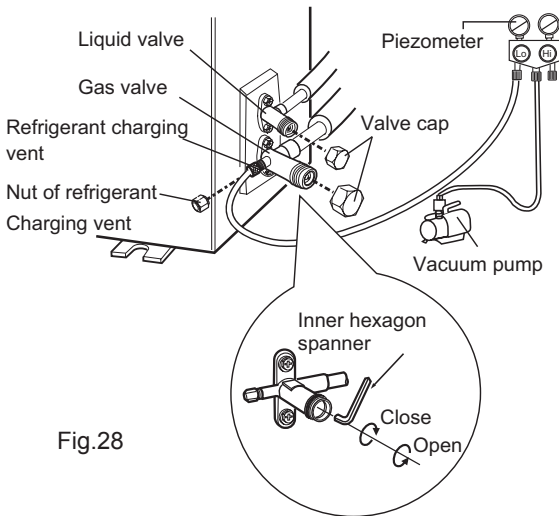

Fig.28

2. Leakage Detection

- (1) With leakage detector:
Check if there is leakage with leakage detector.
- (2) With soap water:
If leakage detector is not available, please use soap water for leakage detection. Apply soap water at the suspected position and keep the soap water for more than 3min. If there are air bubbles coming out of this position, there's a leakage.

8.8 Check after Installation and Test Operation

1. Check after Installation

Check according to the following requirement after finishing installation.

NO.	Items to be checked	Possible malfunction
1	Has the unit been installed firmly?	The unit may drop, shake or emit noise.
2	Have you done the refrigerant leakage test?	It may cause insufficient cooling (heating) capacity.
3	Is heat insulation of pipeline sufficient?	It may cause condensation and water dripping.
4	Is water drained well?	It may cause condensation and water dripping.
5	Is the voltage of power supply according to the voltage marked on the nameplate?	It may cause malfunction or damage the parts.
6	Is electric wiring and pipeline installed correctly?	It may cause malfunction or damage the parts.
7	Is the unit grounded securely?	It may cause electric leakage.
8	Does the power cord follow the specification?	It may cause malfunction or damage the parts.
9	Is there any obstruction in air inlet and air outlet?	It may cause insufficient cooling (heating) capacity.
10	The dust and sundries caused during installation are removed?	It may cause malfunction or damaging the parts.
11	The gas valve and liquid valve of connection pipe are open completely?	It may cause insufficient cooling (heating) capacity.
12	Is the inlet and outlet of piping hole been covered?	It may cause insufficient cooling(heating) capacity or waster eletricity.

2. Test Operation

- (1) Preparation of test operation
 - The client approves the air conditioner installation.
 - Specify the important notes for air conditioner to the client.
- (2) Method of test operation
 - Put through the power, press ON/OFF button on the remote controller to start operation.
 - Press MODE button to select AUTO, COOL, DRY, FAN and HEAT to check whether the operation is normal or not.
 - If the ambient temperature is lower than 16°C(61°F), the air conditioner can't start cooling.

9. Troubleshooting

9.1 Flashing LED of Indoor/Outdoor Unit and Primary Judgement

NO.	Malfunction Name	Display Method of Indoor Unit			A/C status	Possible Causes	
		Dual-8 Code Display	Indicator Display (during blinking, ON 0.5s and OFF 0.5s)				
			Operation Indicator	Cool Indicator			Heating Indicator
1	High pressure protection of system	E1	OFF 3s and blink once			During cooling and drying operation, except indoor fan operates, all loads stop operation. During heating operation, the complete unit stops.	Possible reasons: 1. Refrigerant was superabundant; 2. Poor heat exchange (including filth blockage of heat exchanger and bad radiating environment); Ambient temperature is too high.
2	Antifreezing protection	E2	OFF 3S and blink twice			During cooling and drying operation, compressor and outdoor fan stop while indoor fan operates.	1. Poor air-return in indoor unit; 2. Fan speed is abnormal; 3. Evaporator is dirty.
3	In defect of refrigerant	F0				The Dual-8 Code Display will show F0 and the complete unit stops.	1.In defect of refrigerant; 2.Indoor evaporator temperature sensor works abnormally; 3.The unit has been plugged up somewhere.
4	High discharge temperature protection of compressor	E4	OFF 3S and blink 4 times			During cooling and drying operation, compressor and outdoor fan stop while indoor fan operates. During heating operation, all loads stop.	Please refer to the malfunction analysis (discharge protection, overload).
5	Overcurrent protection	E5	OFF 3S and blink 5 times			During cooling and drying operation, compressor and outdoor fan stop while indoor fan operates. During heating operation, all loads stop.	1. Supply voltage is unstable; 2. Supply voltage is too low and load is too high; 3. Evaporator is dirty.
6	Communication Malfunction	E6	OFF 3S times			During cooling operation, compressor stops while indoor fan motor operates. During heating operation, the complete unit stops.	Refer to the corresponding malfunction analysis.
7	High temperature resistant protection	E8	OFF 3S and blink 8 times			During cooling operation: compressor will stop while indoor fan will operate. During heating operation, the complete unit stops.	Refer to the malfunction analysis (overload, high temperature resistant).
8	EEPROM malfunction	EE			OFF 3S and blink 15 times	During cooling and drying operation, compressor will stop while indoor fan will operate; During heating operation, the complete unit will stop	Replace outdoor control panel AP1
9	Limit/decrease frequency due to high temperature of module	EU		OFF 3S and blink 6 times	OFF 3S and blink 6 times	All loads operate normally, while operation frequency for compressor is decreased	Discharging after the complete unit is de-energized for 20mins, check whether the thermal grease on IPM Module of outdoor control panel AP1 is sufficient and whether the radiator is inserted tightly. If its no use, please replace control panel AP1.
10	Malfunction protection of jumper cap	C5	OFF 3S and blink 15 times			Wireless remote receiver and button are effective, but can not dispose the related command	1. No jumper cap insert on mainboard. 2. Incorrect insert of jumper cap. 3. Jumper cap damaged. 4. Abnormal detecting circuit of mainboard.

NO.	Malfunction Name	Display Method of Indoor Unit			A/C status	Possible Causes	
		Dual-8 Code Display	Indicator Display (during blinking, ON 0.5s and OFF 0.5s)				
			Operation Indicator	Cool Indicator			Heating Indicator
11	Gathering refrigerant	Fo	OFF 3S and blink 1 times			When the outdoor unit receive signal of Gathering refrigerant ,the system will be forced to run under cooling mode for gathering refrigerant	Nominal cooling mode
12	Indoor ambient temperature sensor is open/short circuited	F1		OFF 3S and blink once		During cooling and drying operation, indoor unit operates while other loads will stop; during heating operation, the complete unit will stop operation.	<ol style="list-style-type: none"> 1. Loosening or bad contact of indoor ambient temp. sensor and mainboard terminal. 2. Components in mainboard fell down leads short circuit. 3. Indoor ambient temp. sensor damaged.(check with sensor resistance value chart) 4. Mainboard damaged.
13	Indoor evaporator temperature sensor is open/short circuited	F2		OFF 3S and blink twice		AC stops operation once reaches the setting temperature. Cooling, drying: internal fan motor stops operation while other loads stop operation; heating: AC stop operation	<ol style="list-style-type: none"> 1. Loosening or bad contact of Indoor evaporator temp. sensor and mainboard terminal. 2. Components on the mainboard fall down leads short circuit. 3. Indoor evaporator temp. sensor damaged.(check temp. sensor value chart for testing) 4. Mainboard damaged.
14	Outdoor ambient temperature sensor is open/short circuited	F3		OFF 3S and blink 3 times		During cooling and drying operating, compressor stops while indoor fan operates; During heating operation, the complete unit will stop operation	Outdoor temperature sensor hasnt been connected well or is damaged. Please check it by referring to the resistance table for temperature sensor)
15	Outdoor condenser temperature sensor is open/short circuited	F4		OFF 3S and blink 4 times		During cooling and drying operation, compressor stops while indoor fan will operate; During heating operation, the complete unit will stop operation.	Outdoor temperature sensor hasnt been connected well or is damaged. Please check it by referring to the resistance table for temperature sensor)
16	Outdoor discharge temperature sensor is open/short circuited	F5		OFF 3S and blink 5 times		During cooling and drying operation, compressor will sop after operating for about 3 mins, while indoor fan will operate; During heating operation, the complete unit will stop after operating for about 3 mins.	<ol style="list-style-type: none"> 1.Outdoor temperature sensor hasnt been connected well or is damaged. Please check it by referring to the resistance table for temperature sensor) 2.The head of temperature sensor hasnt been inserted into the copper tube
17	Limit/ decrease frequency due to overload	F6		OFF 3S and blink for 6 times		All loads operate normally, while operation frequency for compressor is decreased	Refer to the malfunction analysis (overload, high temperature resistant)
18	Decrease frequency due to overcurrent	F8		OFF 3S and blink 8 times		All loads operate normally, while operation frequency for compressor is decreased	The input supply voltage is too low; System pressure is too high and overload

NO.	Malfunction Name	Display Method of Indoor Unit				A/C status	Possible Causes
		Dual-8 Code Display	Indicator Display (during blinking, ON 0.5s and OFF 0.5s)				
			Operation Indicator	Cool Indicator	Heating Indicator		
19	Decrease frequency due to high air discharge	F9		OFF 3S and blink 9 times		All loads operate normally, while operation frequency for compressor is decreased	Overload or temperature is too high; Refrigerant is insufficient; Malfunction of electric expansion valve (EKV)
20	Limit/decrease frequency due to antifreezing	FH		OFF 3S and blink 2 times	OFF 3S and blink 2 times	All loads operate normally, while operation frequency for compressor is decreased	Poor air-return in indoor unit or fan speed is too low
21	Voltage for DC bus-bar is too high	PH		OFF 3S and blink 11 times		During cooling and drying operation, compressor will stop while indoor fan will operate; During heating operation, the complete unit will stop operation.	1. Measure the voltage of position L and N on wiring board (XT), if the voltage is higher than 265VAC, turn on the unit after the supply voltage is increased to the normal range. 2.If the AC input is normal, measure the voltage of electrolytic capacitor C on control panel (AP1), if its normal, theres malfunction for the circuit, please replace the control panel (AP1)
22	Voltage of DC bus-bar is too low	PL			OFF 3S and blink 21 times	During cooling and drying operation, compressor will stop while indoor fan will operate; During heating operation, the complete unit will stop	1. Measure the voltage of position L and N on wiring board (XT), if the voltage is higher than 150VAC, turn on the unit after the supply voltage is increased to the normal range. 2.If the AC input is normal, measure the voltage of electrolytic capacitor C on control panel (AP1), if its normal, theres malfunction for the circuit, please replace the control panel (AP1)
23	Compressor Min frequency in test state	P0		(during blinking, ON 0.25s and OFF 0.25s)	(during blinking, ON 0.25s and OFF 0.25s)		Showing during min. cooling or min. heating test
24	Compressor rated frequency in test state	P1		(during blinking, ON 0.25s and OFF 0.25s)	(during blinking, ON 0.25s and OFF 0.25s)		Showing during nominal cooling or nominal heating test
25	Compressor maximum frequency in test state	P2		(during blinking, ON 0.25s and OFF 0.25s)	(during blinking, ON 0.25s and OFF 0.25s)		Showing during max. cooling or max. heating test

NO.	Malfunction Name	Display Method of Indoor Unit			A/C status	Possible Causes	
		Dual-8 Code Display	Indicator Display (during blinking, ON 0.5s and OFF 0.5s)				
			Operation Indicator	Cool Indicator			Heating Indicator
26	Compressor intermediate frequency in test state	P3		(during blinking, ON 0.25s and OFF 0.25s)	(during blinking, ON 0.25s and OFF 0.25s)	Showing during middle cooling or middle heating test	
27	Overcurrent protection of phase current for compressor	P5		OFF 3S and blink 15 times		During cooling and drying operation, compressor will stop while indoor fan will operate; During heating operation, the complete unit will stop operation. Refer to the malfunction analysis (IPM protection, loss of synchronism protection and overcurrent protection of phase current for compressor).	
28	Charging malfunction of capacitor	PU			OFF 3S and blink 17 times	During cooling and drying operation, compressor will stop while indoor fan will operate; During heating operation, the complete unit will stop Refer to the part three—charging malfunction analysis of capacitor	
29	Malfunction of module temperature sensor circuit	P7			OFF 3S and blink 18 times	During cooling and drying operation, compressor will stop while indoor fan will operate; During heating operation, the complete unit will stop Replace outdoor control panel AP1	
30	Module high temperature protection	P8			OFF 3S and blink 19 times	During cooling operation, compressor will stop while indoor fan will operate; During heating operation, the complete unit will stop After the complete unit is de-energized for 20mins, check whether the thermal grease on IPM Module of outdoor control panel AP1 is sufficient and whether the radiator is inserted tightly. If its no use, please replace control panel AP1.	
31	Decrease frequency due to high temperature resistant during heating operation	H0			OFF 3S and blink 10 times	All loads operate normally, while operation frequency for compressor is decreased Refer to the malfunction analysis (overload, high temperature resistant)	
32	Static dedusting protection	H2			OFF 3S and blink twice		
33	Overload protection for compressor	H3			OFF 3S and blink 3 times	During cooling and drying operation, compressor will stop while indoor fan will operate; During heating operation, the complete unit will stop operation. 1. Wiring terminal OVC-COMP is loosened. In normal state, the resistance for this terminal should be less than 1ohm. 2.Refer to the malfunction analysis (discharge protection, overload)	



NO.	Malfunction Name	Display Method of Indoor Unit			A/C status	Possible Causes	
		Dual-8 Code Display	Indicator Display (during blinking, ON 0.5s and OFF 0.5s)				
			Operation Indicator	Cool Indicator			Heating Indicator
34	System is abnormal	H4			OFF 3S and blink 4 times	During cooling and drying operation, compressor will stop while indoor fan will operate; During heating operation, the complete unit will stop operation.	Refer to the malfunction analysis (overload, high temperature resistant)
35	IPM protection	H5			OFF 3S and blink 5 times	During cooling and drying operation, compressor will stop while indoor fan will operate; During heating operation, the complete unit will stop operation.	Refer to the malfunction analysis (IPM protection, loss of synchronism protection and overcurrent protection of phase current for compressor.
36	PFC protection	HC				During cooling and drying operation, compressor will stop while indoor fan will operate; During heating operation, the complete unit will stop operation.	Replace outdoor control panel AP1 or Reactor
37	Internal motor (fan motor) do not operate	H6	OFF 3S and blink 11 times			Internal fan motor, external fan motor, compressor and electric heater stop operation, guide louver stops at present location.	<ol style="list-style-type: none"> 1. Bad contact of DC motor feedback terminal. 2. Bad contact of DC motor control end. 3. Fan motor is stalling. 4. Motor malfunction. 5. Malfunction of mainboard rev detecting circuit.
38	Desynchronizing of compressor	H7			OFF 3S and blink 7 times	During cooling and drying operation, compressor will stop while indoor fan will operate; During heating operation, the complete unit will stop operation.	Refer to the malfunction analysis (IPM protection, loss of synchronism protection and overcurrent protection of phase current for compressor.
39	Malfunction of detecting plate(WIFI)	JF				Loads operate normally, while the unit can't be normally controlled by APP	<ol style="list-style-type: none"> 1. Main board of indoor unit is damaged; 2. Detection board is damaged; 3. The connection between indoor unit and detection board is not good;
40	Outdoor DC fan motor malfunction	L3	OFF 3S and blink 23 times			Outdoor DC fan motor malfunction lead to compressor stop operation,	DC fan motor malfunction or system blocked or the connector loosed
41	power protection	L9	OFF 3S and blink 20 times			compressor stop operation and Outdoor fan motor will stop 30s latter , 3 minutes latter fan motor and compressor will restart	To protect the electrical components when detect high power
42	Indoor unit and outdoor unit doesn't match	LP	OFF 3S and blink 19 times			compressor and Outdoor fan motor can't work	Indoor unit and outdoor unit doesn't match
43	Failure start-up	LC			OFF 3S and blink 11 times	During cooling and drying operation, compressor will stop while indoor fan will operate; During heating operation, the complete unit will stop operation.	Refer to the malfunction analysis

NO.	Malfunction Name	Display Method of Indoor Unit			A/C status	Possible Causes	
		Dual-8 Code Display	Indicator Display (during blinking, ON 0.5s and OFF 0.5s)				
			Operation Indicator	Cool Indicator			Heating Indicator
44	Malfunction of phase current detection circuit for compressor	U1			OFF 3S and blink 13 times	During cooling and drying operation, compressor will stop while indoor fan will operate; During heating operation, the complete unit will stop	Replace outdoor control panel AP1
45	Malfunction of voltage dropping for DC bus-bar	U3			OFF 3S and blink 20 times	During cooling and drying operation, compressor will stop while indoor fan will operate; During heating operation, the complete unit will stop	Supply voltage is unstable
46	Malfunction of complete units current detection	U5		OFF 3S and blink 13 times		During cooling and drying operation, the compressor will stop while indoor fan will operate; During heating operating, the complete unit will stop operation.	Theres circuit malfunction on outdoor units control panel AP1, please replace the outdoor units control panel AP1.
47	The four-way valve is abnormal	U7		OFF 3S and blink 20 times		If this malfunction occurs during heating operation, the complete unit will stop operation.	1.Supply voltage is lower than AC175V; 2.Wiring terminal 4V is loosened or broken; 3.4V is damaged, please replace 4V.
48	Zero-crossing malfunction of outdoor unit	U9	OFF 3S and blink 18 times			During cooling operation, compressor will stop while indoor fan will operate; during heating,the complete unit will stop operation.	Replace outdoor control panel AP1
49	Defrosting				once (during blinking, ON 10s and OFF	heating mode. Compressor will operate while indoor fan will stop	Its the normal state

50	Undefined outdoor unit error	oE				<p>Cool: compressor and outdoor fan stops operation, while indoor fan operates; Heat: compressor, outdoor fan and indoor fan stop operation.</p>	<p>1. Outdoor ambient temperature exceeds the operation range of unit (eg: less than -20°C or more than 60°C for cooling; more than 30°C for heating); 2. Failure startup of compressor? 3. Are wires of compressor not connected tightly? 4. Is compressor damaged? 5. Is main board damaged?</p>
51	Anti-freezing protection for evaporator	E2				Not the error code. It's the status code for the operation.	
52	Cold air prevention protection	E9				Not the error code. It's the status code for the operation.	
53	Refrigerant recovery mode	Fo				Refrigerant recovery. The Serviceman operates it for maintenance	

Analysis or processing of some of the malfunction display:

1. Compressor discharge protection

Possible reasons: shortage of refrigerant; blockage of air filter; poor ventilation or air flow short pass for condenser; the system has noncondensing gas (such as air, water etc.); blockage of capillary assy (including filter); leakage inside four-way valve causes incorrect operation; malfunction of compressor; malfunction of protection relay; malfunction of discharge sensor; outdoor temperature too high.

Processing method: refer to the malfunction analysis in the above section.

2. Low voltage overcurrent protection

Possible reason: Sudden drop of supply voltage.

3. Communication malfunction

Processing method: Check if communication signal cable is connected reliably.

4. Sensor open or short circuit

Processing method: Check whether sensor is normal, connected with the corresponding position on the controller and if damage of lead wire is found.

5. Compressor over load protection

Possible reasons: insufficient or too much refrigerant; blockage of capillary and increase of suction temp.; improper running of compressor, burning in or stuck of bearing, damage of discharge valve; malfunction of protector.

Processing method: adjust refrigerant amount; replace the capillary; replace the compressor; use universal meter to check if the contactor of compressor is fine when it is not overheated, if not replace the protector.

6. System malfunction

Overload protection. When tube temperature (Check the temperature of outdoor heat exchanger when cooling and check the temperature of indoor heat exchanger when heating) is too high, protection will be activated.

Possible reasons: Outdoor temperature is too high when cooling; insufficient outdoor air circulation; refrigerant flow malfunction.

Please refer to the malfunction analysis in the previous section for handling method.

7. IPM module protection

Processing method: Once the module malfunction happens, if it persists for a long time and can not be self-canceled, cut off the power and turn off the unit, and then re-energize the unit again after about 10 min. After repeating the procedure for several times, if the malfunction still exists, replace the module.

9.2 How to Check Simply the Main Part

Indoor unit

1. Malfunction of Temperature Sensor F1, F2

Main detection points:

- Is the wiring terminal between the temperature sensor and the controller loosened or poorly contacted?
- Is there short circuit due to trip-over of the parts?
- Is the temperature sensor broken?
- Is mainboard broken?

Malfunction diagnosis process:

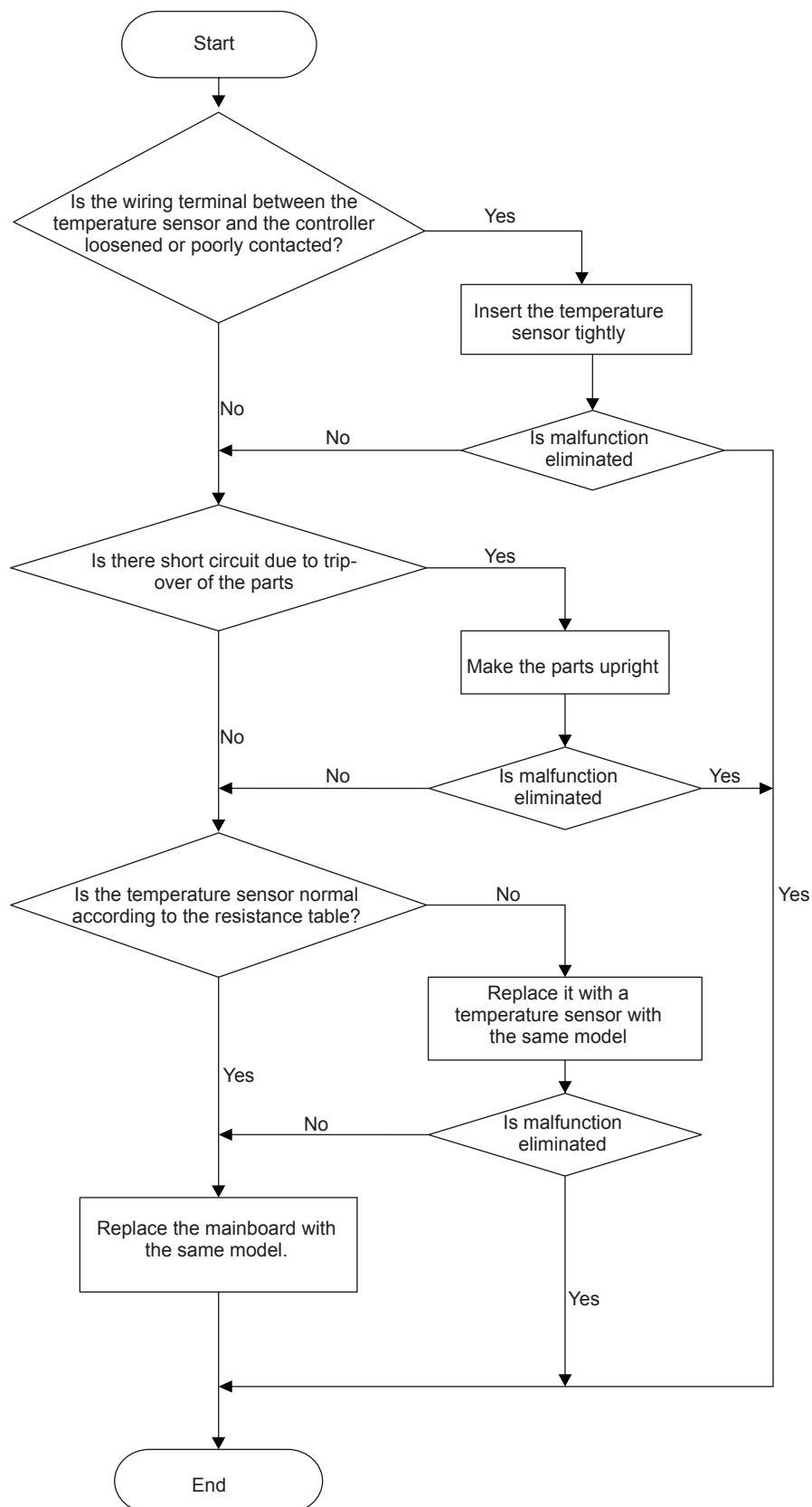

2.Malfunction of Blocked Protection of IDU Fan Motor H6

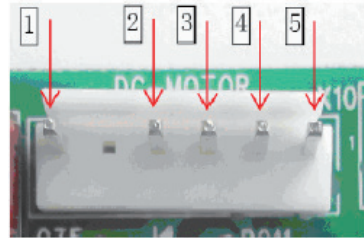
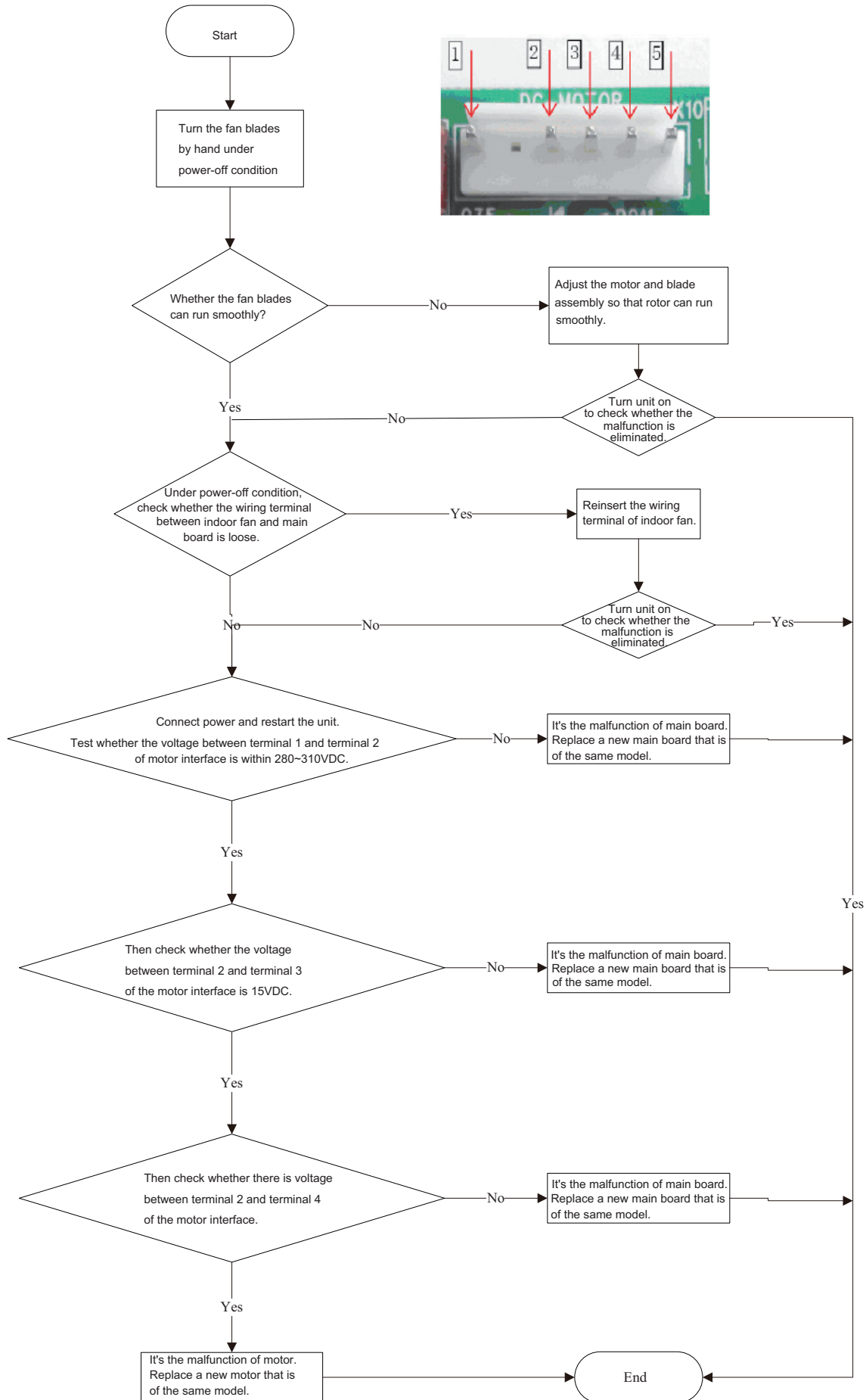

3. Malfunction of Protection of Jumper Cap C5

Main detection points:

- Is there jumper cap on the mainboard?
- Is the jumper cap inserted correctly and tightly?
- The jumper is broken?
- The motor is broken?
- Detection circuit of the mainboard is defined abnormal?

Malfunction diagnosis process:

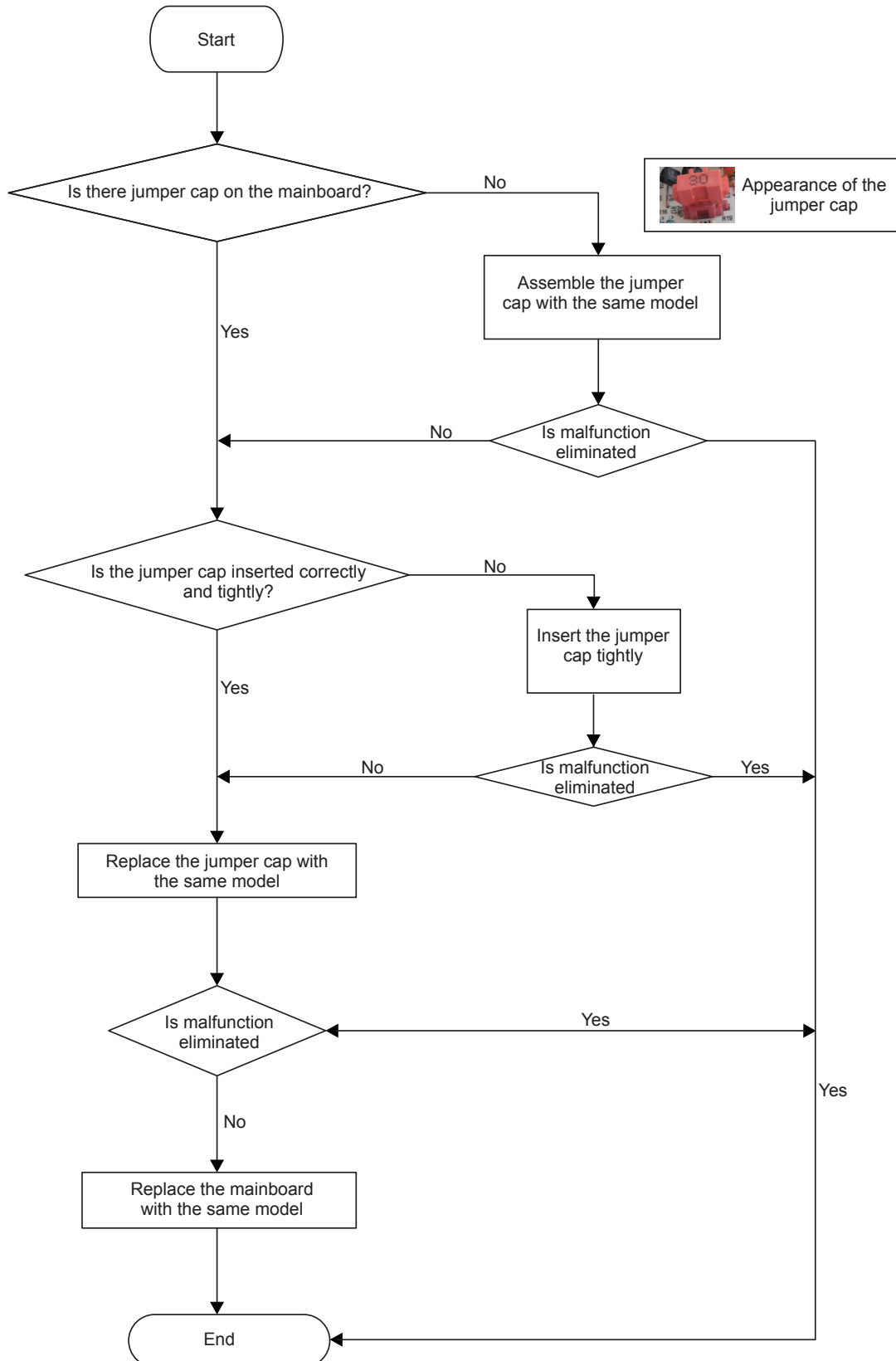

4. Malfunction of Overcurrent Protection E5

Main detection points:

- Is the supply voltage unstable with big fluctuation?
- Is the supply voltage too low with overload?
- Hardware trouble?

Malfunction diagnosis process:

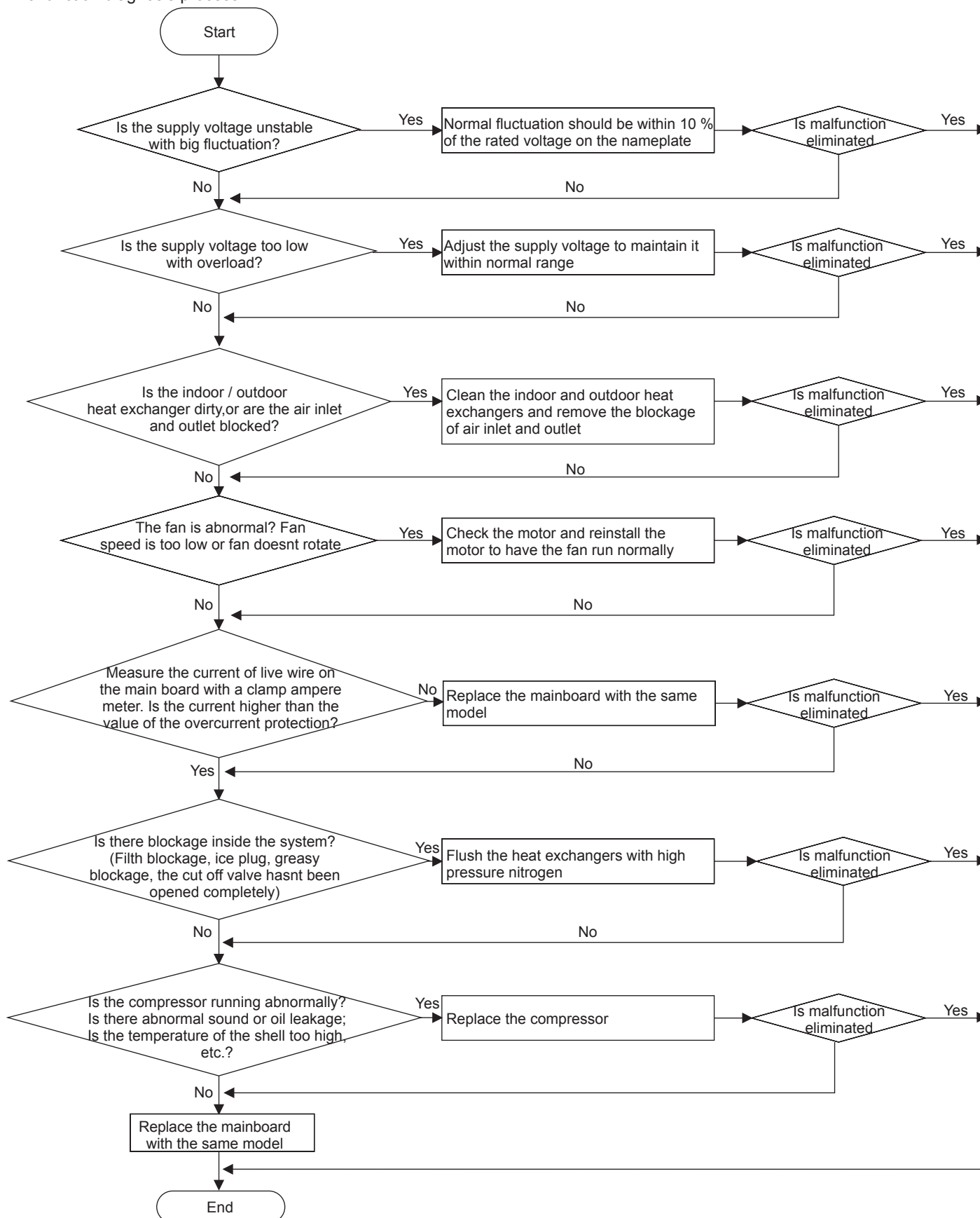

5. Malfunction of Zero-crossing Inspection Circuit Malfunction of the IDU Fan Motor U8

Main detection points:

- Instant energization after de-energization while the capacitor discharges slowly?
- The zero-cross detection circuit of the mainboard is defined abnormal?

Malfunction diagnosis process:

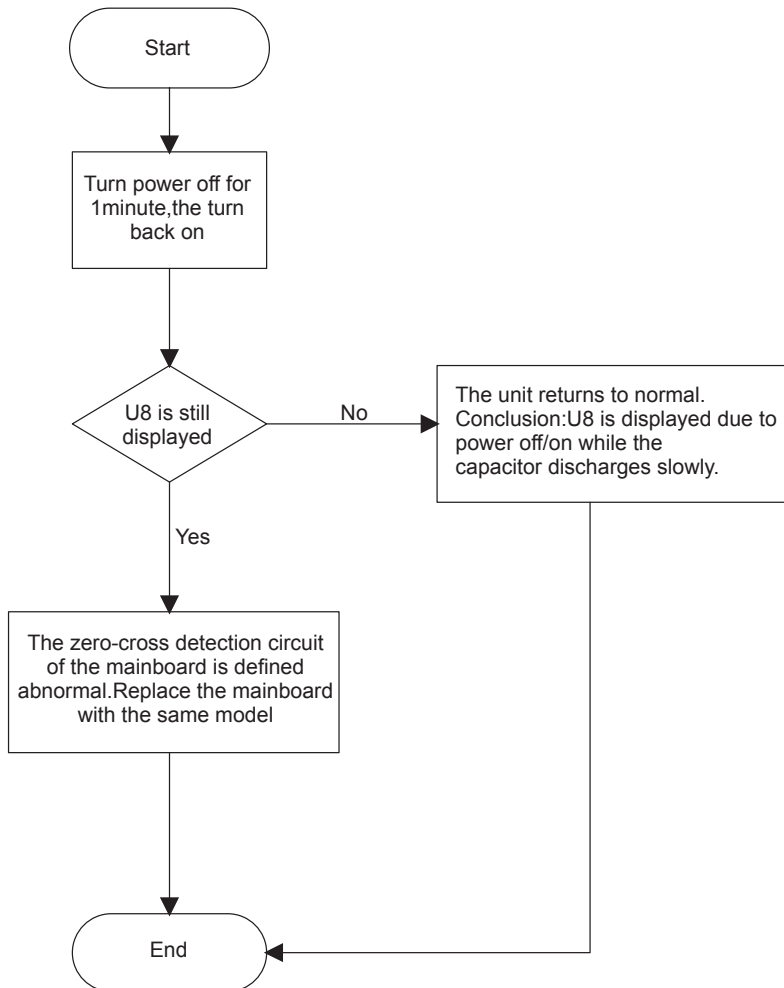

6. Malfunction of communication E6

Main detection points:

- Check if the connection wire and the built-in wiring of indoor and outdoor unit are connected well and without damage;
- If the communication circuit of indoor mainboard is damaged? If the communication circuit of outdoor mainboard (AP1) is damaged?

Malfunction diagnosis process:

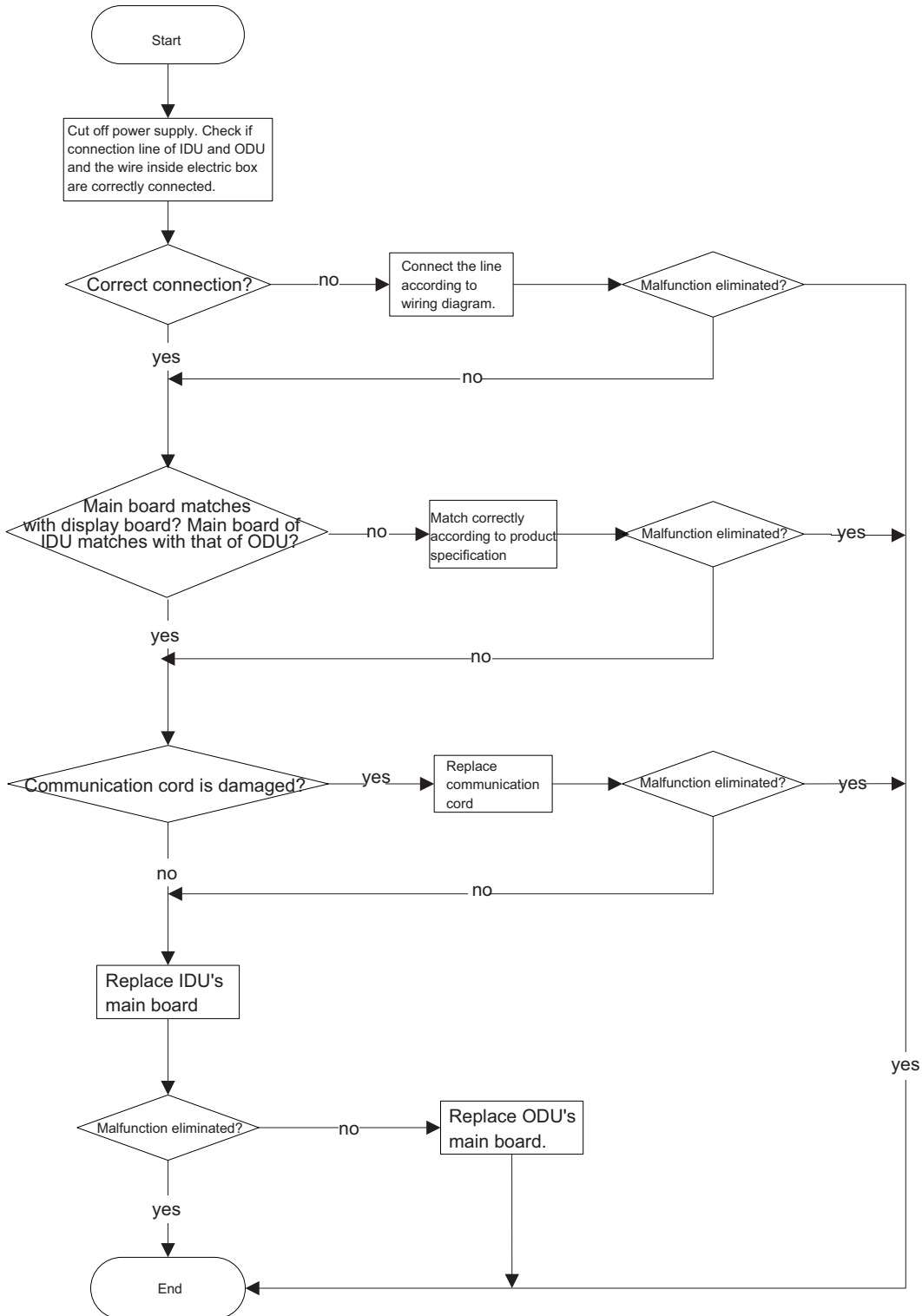

7. Malfunction of detecting plate(WIFI) JF

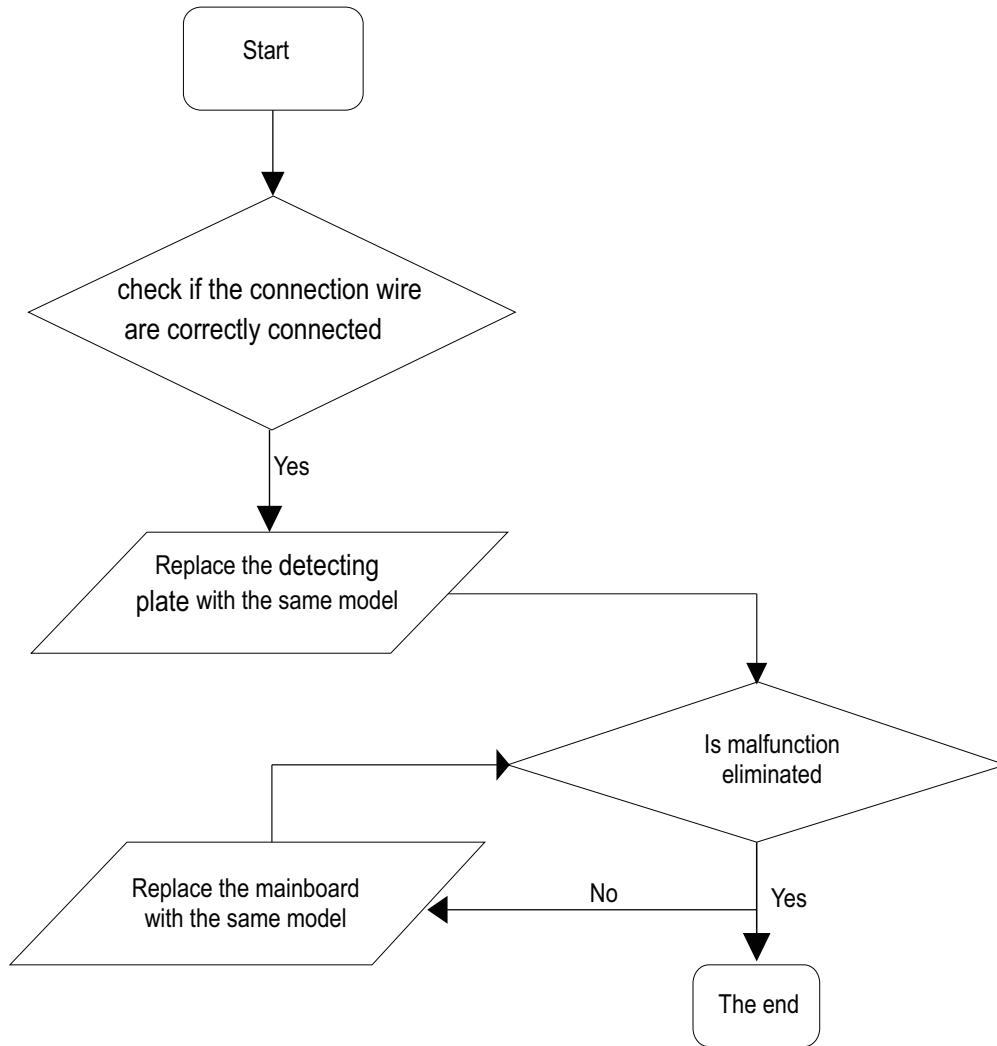

Outdoor unit

(1) Capacitor charge fault (Fault with outdoor unit) (AP1 below refers to the outdoor control panel)

Main Check Points:

- Use AC voltmeter to check if the voltage between terminal L and N on the wiring board is within 210VAC~240VAC.
- If the reactor (L) is correctly connected? If the connection is loose or fallen? If the reactor (L) is damaged?

Fault diagnosis process:

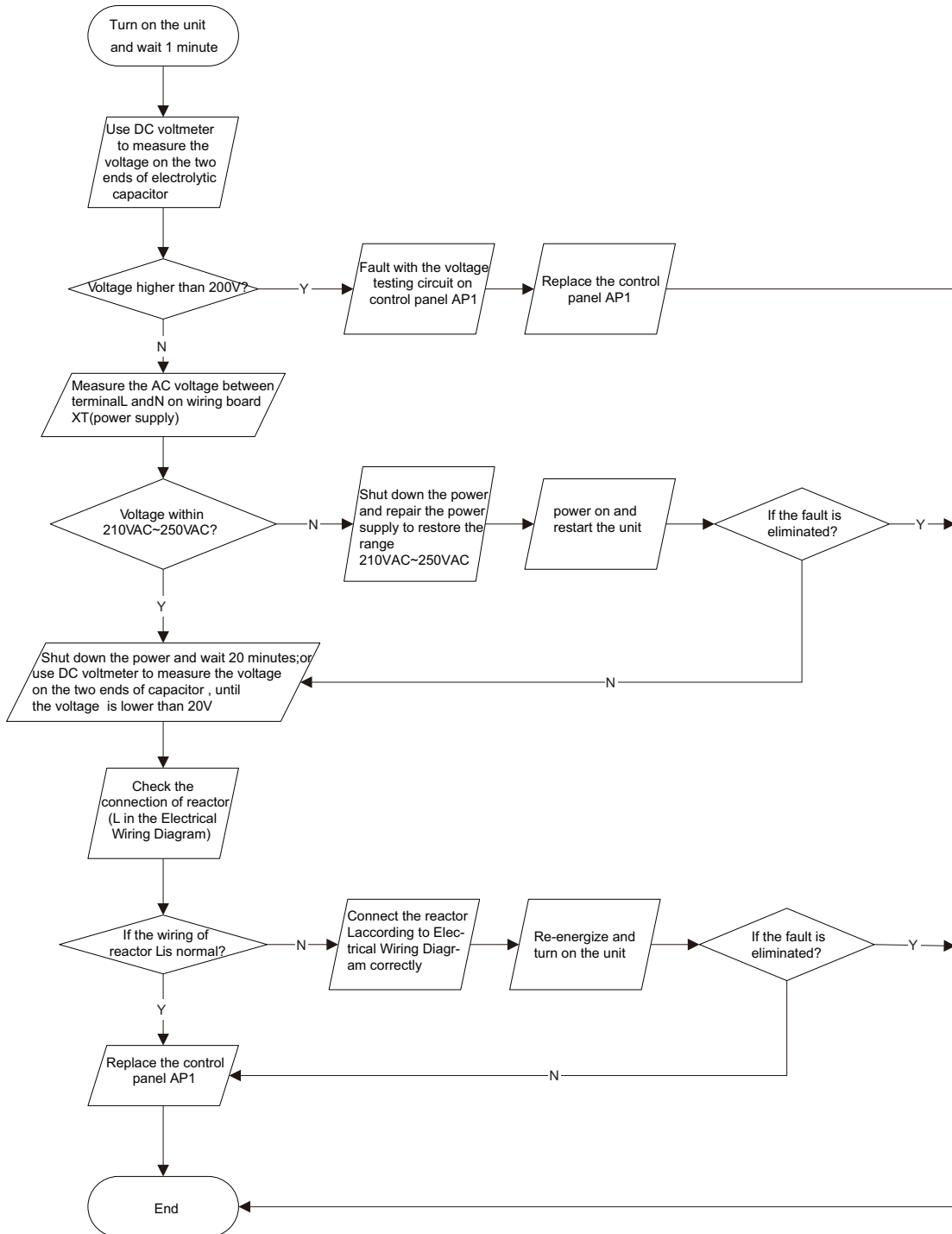

(2) IPM protection, phase current overcurrent (the control board as below indicates the control board of outdoor unit) H5/P5

Mainly detect:

- (1) Compressor COMP terminal
- (2) voltage of power supply
- (3) compressor
- (4) Refrigerant-charging volume
- (5) air outlet and air inlet of outdoor/indoor unit

Troubleshooting:

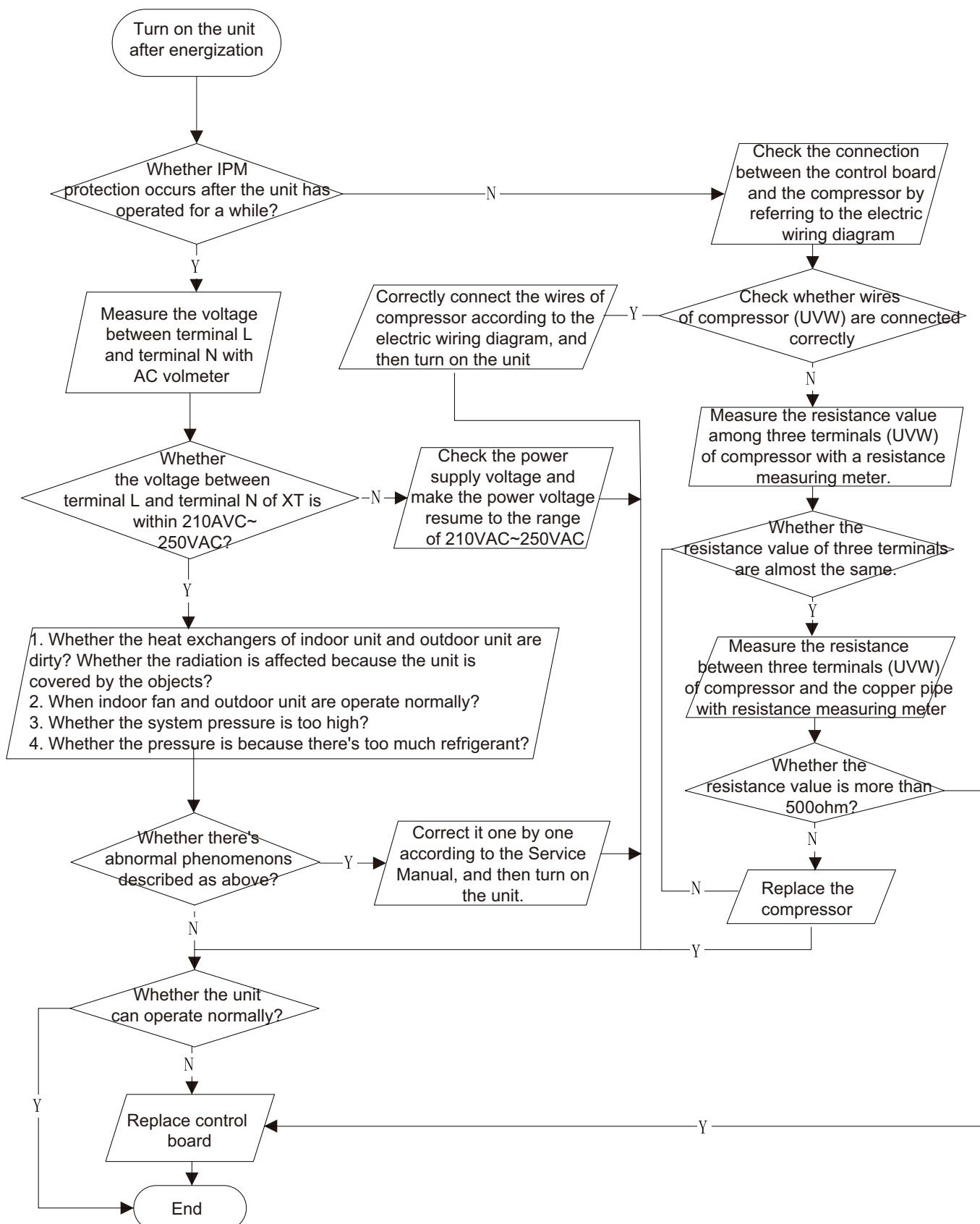

(4) Start-up failure (following AP1 for outdoor unit control board)

Mainly detect:

- Whether the compressor wiring is connected correct?
- Is compressor broken?
- Is time for compressor stopping enough?

Fault diagnosis process:

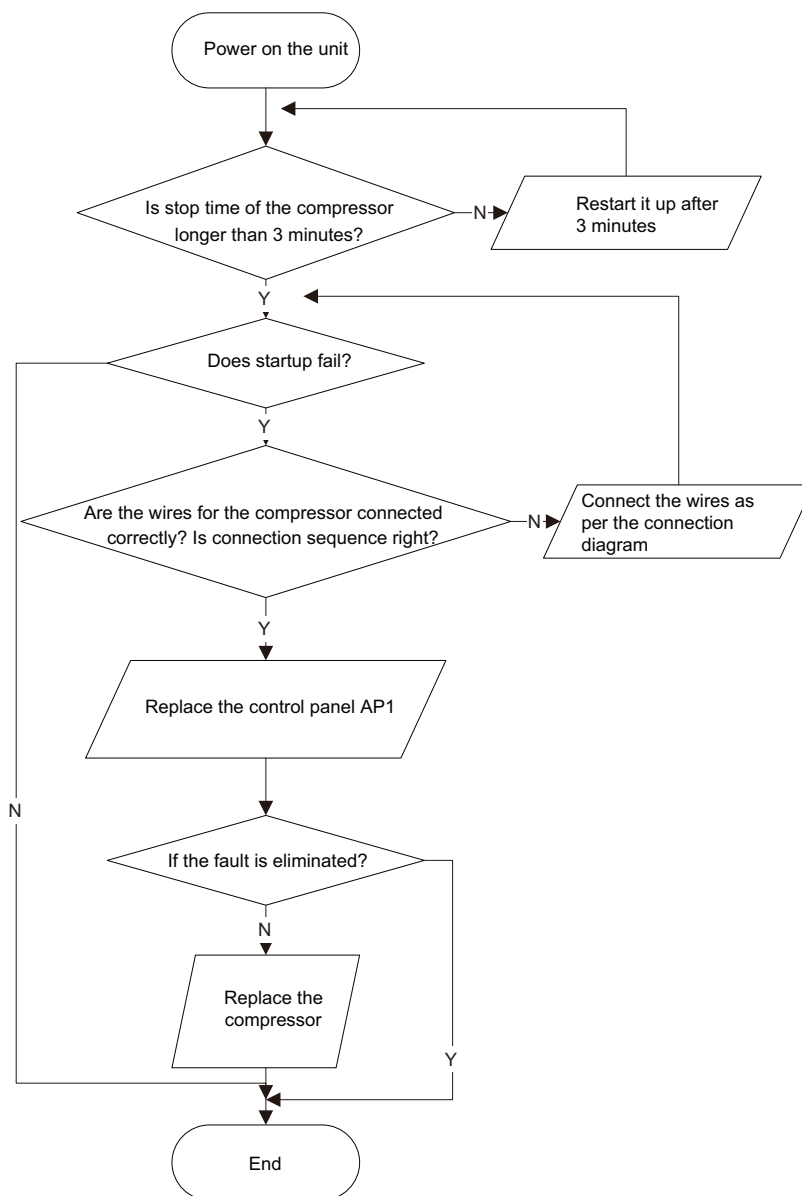

(5) Out of step diagnosis for the compressor (AP1 hereinafter refers to the control board of the outdoor unit)

Mainly detect:

- Whether the system pressure is too high?
- Whether the input voltage is too low?

Fault diagnosis process:

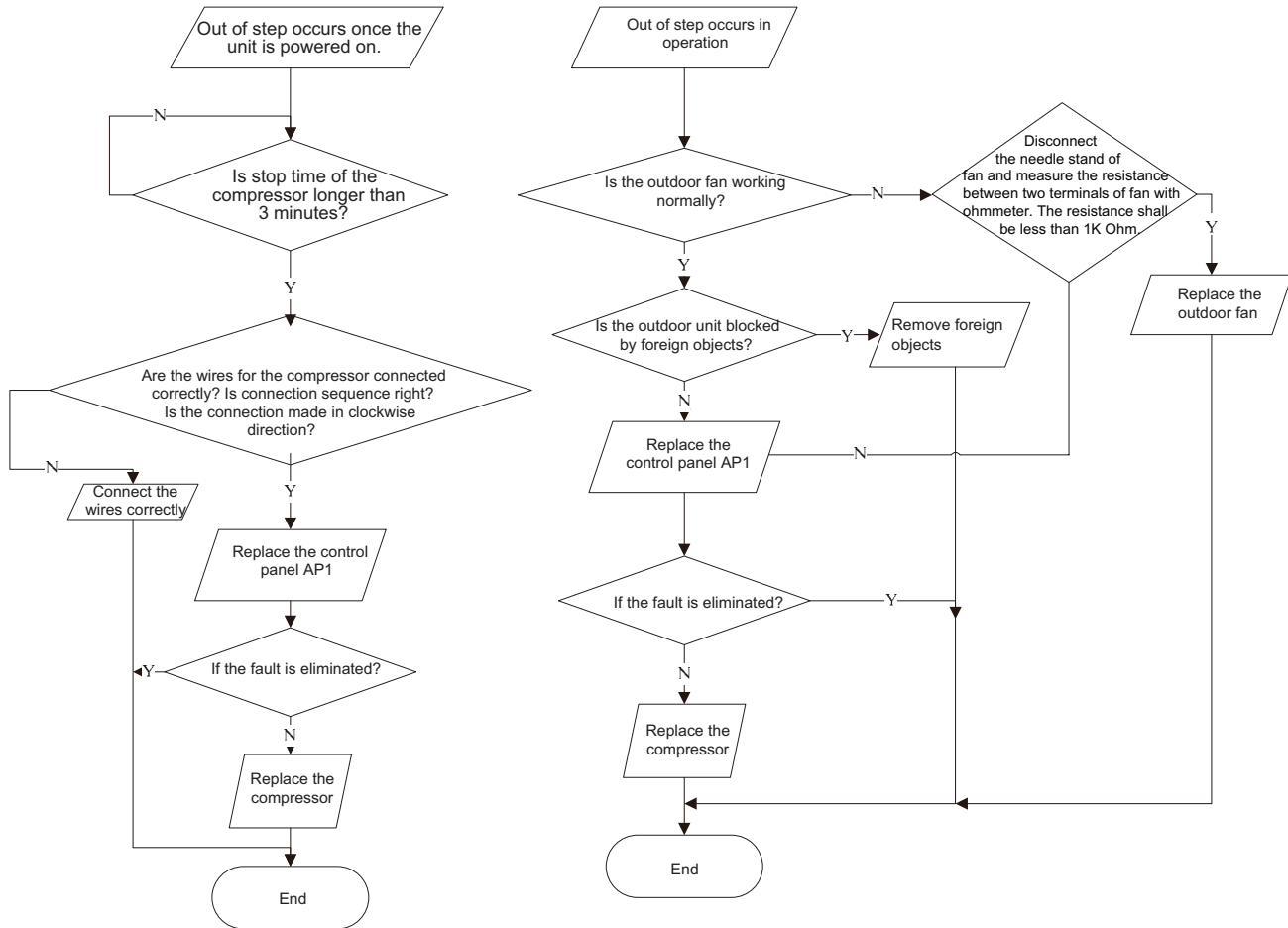

(6) Overload and air exhaust malfunction diagnosis (following AP1 for outdoor unit control board)

Mainly detect:

- Whether the PMV is connected well or not? Is PMV damaged?
- Is refrigerant leaked?

Fault diagnosis process:

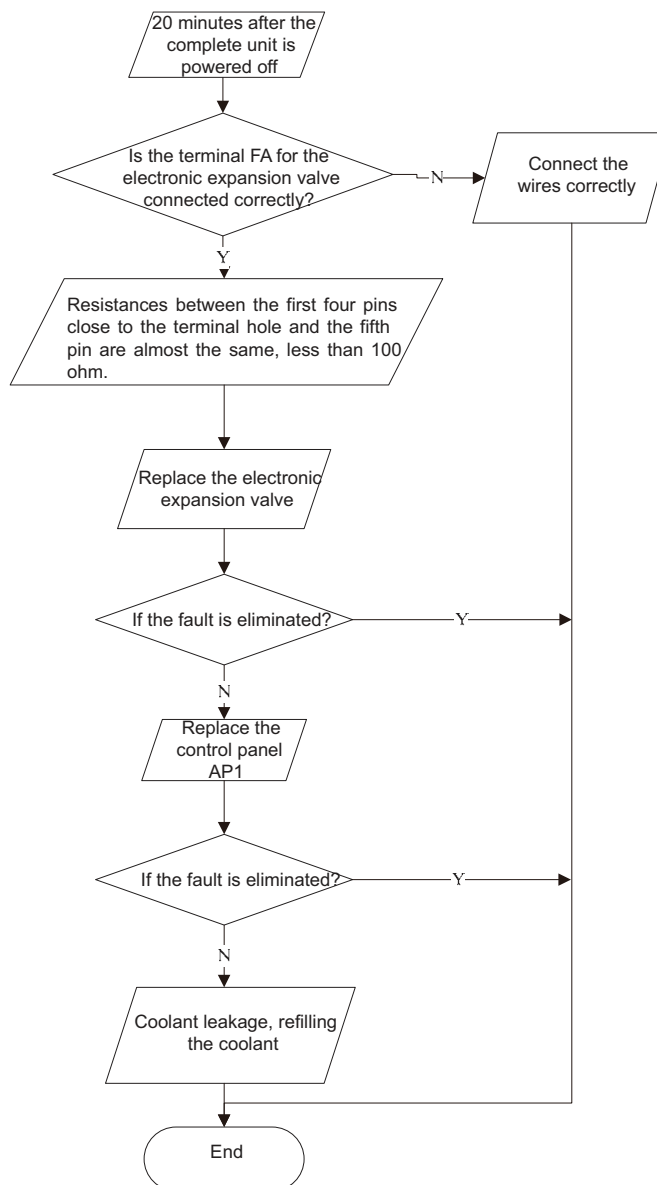

(7) High-pressure Protection

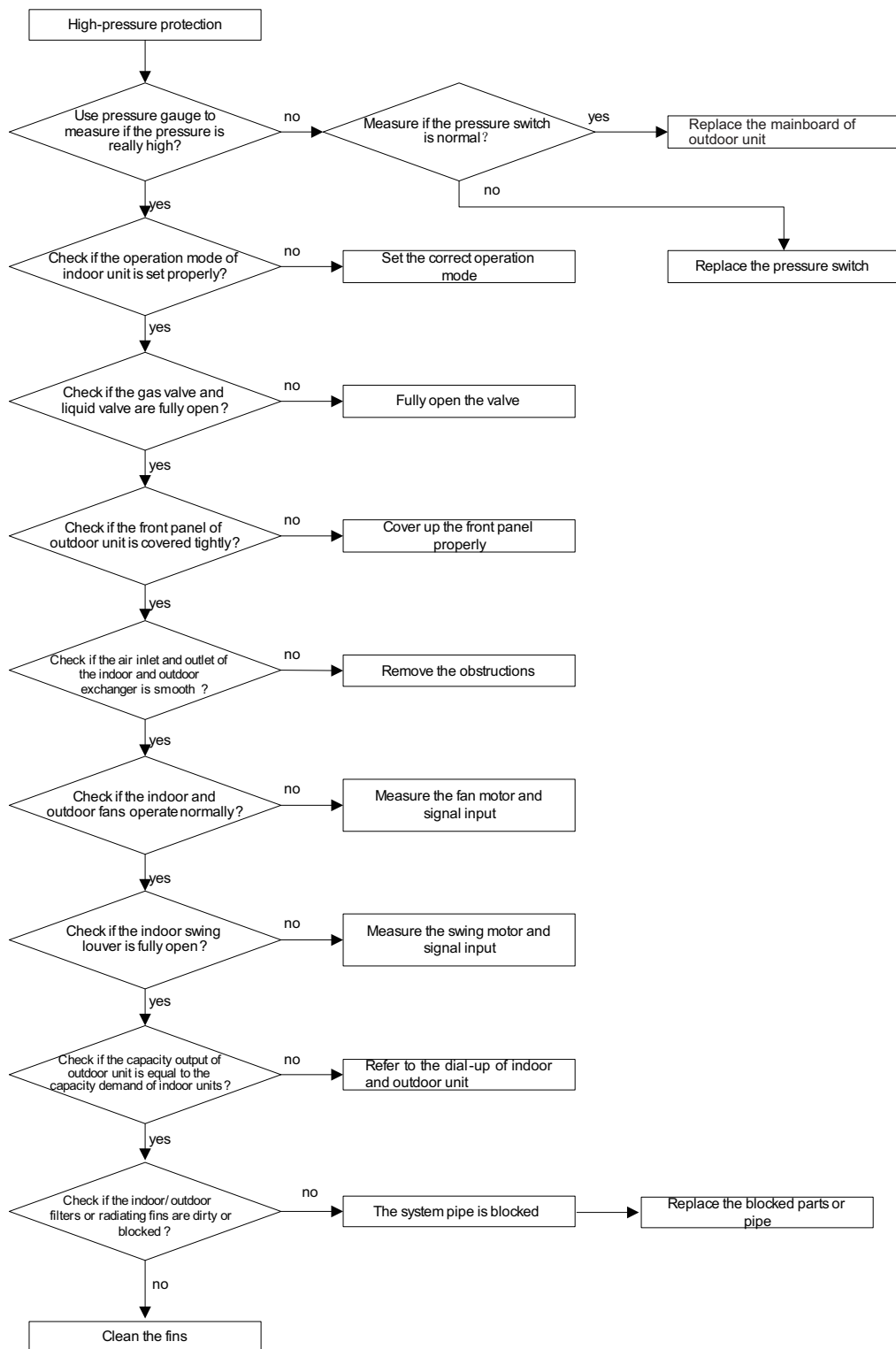

(8) Communication malfunction: (following AP1 for outdoor unit control board)

Mainly detect:

- Is there any damage for the indoor unit mainboard communication circuit? Is communication circuit damaged?
- Detect the indoor and outdoor units connection wire and indoor and outdoor units inside wiring is connect well or not, if is there any damage?

Fault diagnosis process:

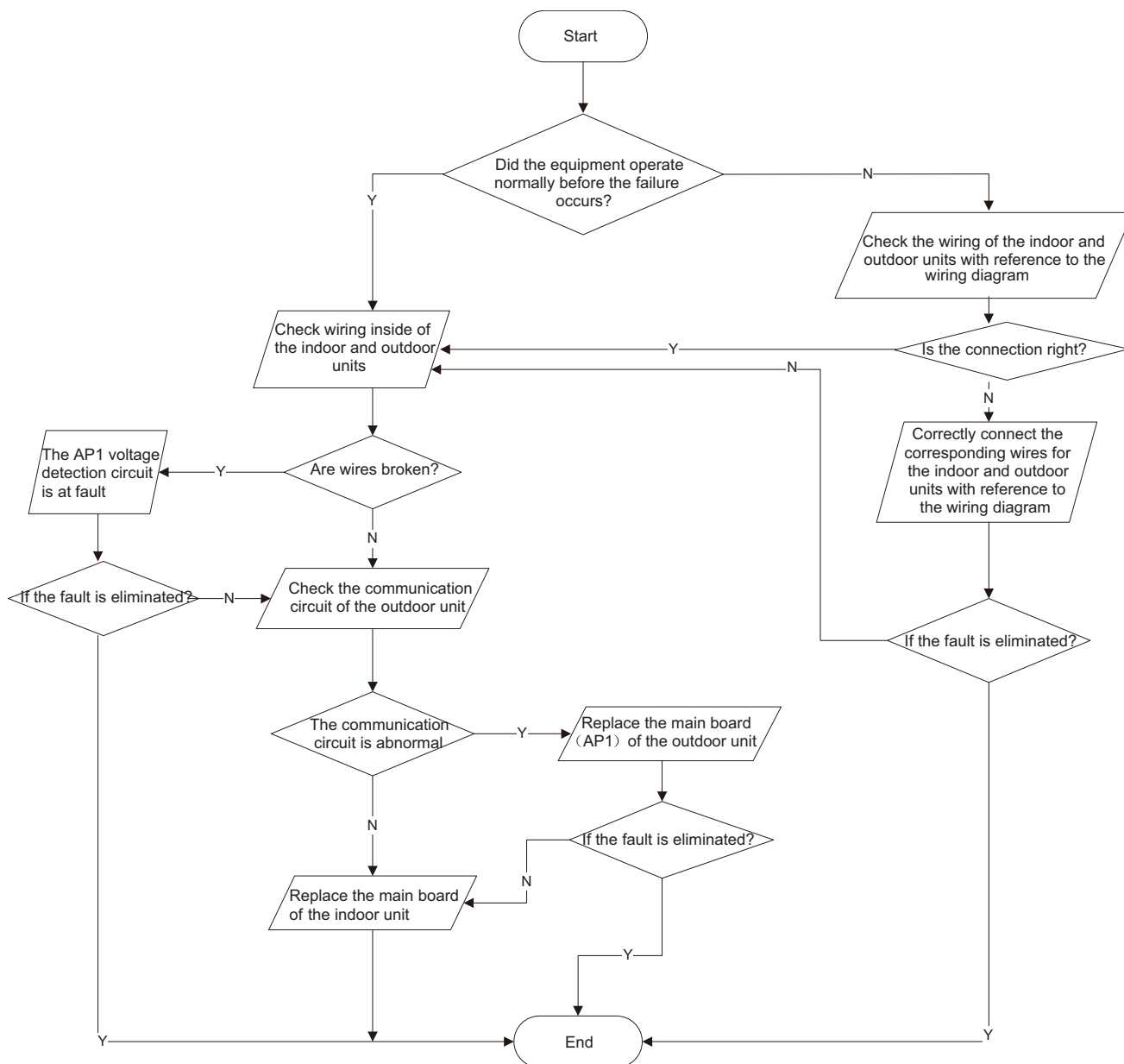

(9) Communication malfunction:(following AP1 for outdoor unit control board)

Mainly detect:

Detect the indoor and outdoor units connection wire and indoor and outdoor units inside wiring is connect well or not, If is there any damage?

Is there any damage for the indoor unit mainboard communication circuit? Is communication circuit damaged?

The flow chart fir malfunction detect:



9.3 Troubleshooting for Normal Malfunction

1. Air Conditioner Cant be Started Up

Possible Causes	Discriminating Method (Air conditioner Status)	Troubleshooting
No power supply, or poor connection for power plug	After energization, operation indicator isnt bright and the buzzer cant give out sound	Confirm whether its due to power failure. If yes, wait for power recovery. If not, check power supply circuit and make sure the power plug is connected well.
Wrong wire connection between indoor unit and outdoor unit, or poor connection for wiring terminals	Under normal power supply circumstances, operation indicator isnt bright after energization	Check the circuit according to circuit diagram and connect wires correctly. Make sure all wiring terminals are connected firmly
Electric leakage for air conditioner	After energization, room circuit breaker trips off at once	Make sure the air conditioner is grounded reliably Make sure wires of air conditioner is connected correctly Check the wiring inside air conditioner. Check whether the insulation layer of power cord is damaged; if yes, place the power cord.
Model selection for air switch is improper	After energization, air switch trips off	Select proper air switch
Malfunction of remote controller	After energization, operation indicator is bright, while no display on remote controller or buttons have no action.	Replace batteries for remote controller Repair or replace remote controller

2. Poor Cooling (heating) for Air Conditioner

Possible Causes	Discriminating Method (Air conditioner Status)	Troubleshooting
Set temperature is improper	Observe the set temperature on remote controller	Adjust the set temperature
Rotation speed of the IDU fan motor is set too low	Small wind blow	Set the fan speed at high or medium
Filter of indoor unit is blocked	Check the filter to see its blocked	Clean the filter
Installation position for indoor unit and outdoor unit is improper	Check whether the installation position is proper according to installation requirement for air conditioner	Adjust the installation position, and install the rainproof and sunproof for outdoor unit
Refrigerant is leaking	Discharged air temperature during cooling is higher than normal discharged wind temperature; Discharged air temperature during heating is lower than normal discharged wind temperature; Units pressure is much lower than regulated range	Find out the leakage causes and deal with it. Add refrigerant.
Malfunction of 4-way valve	Blow cold wind during heating	Replace the 4-way valve
Malfunction of capillary	Discharged air temperature during cooling is higher than normal discharged wind temperature; Discharged air temperature during heating is lower than normal discharged wind temperature; Unit pressure is much lower than regulated range. If refrigerant isnt leaking, part of capillary is blocked	Replace the capillary
Flow volume of valve is insufficient	The pressure of valves is much lower than that stated in the specification	Open the valve completely
Malfunction of horizontal louver	Horizontal louver cant swing	Refer to point 3 of maintenance method for details
Malfunction of the IDU fan motor	The IDU fan motor cant operate	Refer to troubleshooting for H6 for maintenance method in details
Malfunction of the ODU fan motor	The ODU fan motor cant operate	Refer to point 4 of maintenance method for details
Malfunction of compressor	Compressor cant operate	Refer to point 5 of maintenance method for details

3. Horizontal Louver Cant Swing

Possible Causes	Discriminating Method (Air conditioner Status)	Troubleshooting
Wrong wire connection, or poor connection	Check the wiring status according to circuit diagram	Connect wires according to wiring diagram to make sure all wiring terminals are connected firmly
Stepping motor is damaged	Stepping motor cant operate	Repair or replace stepping motor
Main board is damaged	Others are all normal, while horizontal louver cant operate	Replace the main board with the same model

4. ODU Fan Motor Cant Operate

Possible causes	Discriminating method (air conditioner status)	Troubleshooting
Wrong wire connection, or poor connection	Check the wiring status according to circuit diagram	Connect wires according to wiring diagram to make sure all wiring terminals are connected firmly
Capacity of the ODU fan motor is damaged	Measure the capacity of fan capacitor with an universal meter and find that the capacity is out of the deviation range indicated on the nameplate of fan capacitor.	Replace the capacity of fan
Power voltage is a little low or high	Use universal meter to measure the power supply voltage. The voltage is a little high or low	Suggest to equip with voltage regulator
Motor of outdoor unit is damaged	When unit is on, cooling/heating performance is bad and ODU compressor generates a lot of noise and heat.	Change compressor oil and refrigerant. If no better, replace the compressor with a new one

5. Compressor Cant Operate

Possible causes	Discriminating method (air conditioner status)	Troubleshooting
Wrong wire connection, or poor connection	Check the wiring status according to circuit diagram	Connect wires according to wiring diagram to make sure all wiring terminals are connected firmly
Capacity of compressor is damaged	Measure the capacity of fan capacitor with an universal meter and find that the capacity is out of the deviation range indicated on the nameplate of fan capacitor.	Replace the compressor capacitor
Power voltage is a little low or high	Use universal meter to measure the power supply voltage. The voltage is a little high or low	Suggest to equip with voltage regulator
Coil of compressor is burnt out	Use universal meter to measure the resistance between compressor terminals and its 0	Repair or replace compressor
Cylinder of compressor is blocked	Compressor cant operate	Repair or replace compressor

6. Air Conditioner is Leaking

Possible causes	Discriminating method (air conditioner status)	Troubleshooting
Drain pipe is blocked	Water leaking from indoor unit	Eliminate the foreign objects inside the drain pipe
Drain pipe is broken	Water leaking from drain pipe	Replace drain pipe
Wrapping is not tight	Water leaking from the pipe connection place of indoor unit	Wrap it again and bundle it tightly

7. Abnormal Sound and Vibration

Possible causes	Discriminating method (air conditioner status)	Troubleshooting
When turn on or turn off the unit, the panel and other parts will expand and theres abnormal sound	Theres the sound of "PAPA"	Normal phenomenon. Abnormal sound will disappear after a few minutes.
When turn on or turn off the unit, theres abnormal sound due to flow of refrigerant inside air conditioner	Water-running sound can be heard	Normal phenomenon. Abnormal sound will disappear after a few minutes.
Foreign objects inside the indoor unit or therere parts touching together inside the indoor unit	Theres abnormal sound fro indoor unit	Remove foreign objects. Adjust all parts position of indoor unit, tighten screws and stick damping plaster between connected parts
Foreign objects inside the outdoor unit or therere parts touching together inside the outdoor unit	Theres abnormal sound fro outdoor unit	Remove foreign objects. Adjust all parts position of outdoor unit, tighten screws and stick damping plaster between connected parts
Short circuit inside the magnetic coil	During heating, the way valve has abnormal electromagnetic sound	Replace magnetic coil
Abnormal shake of compressor	Outdoor unit gives out abnormal sound	Adjust the support foot mat of compressor, tighten the bolts
Abnormal sound inside the compressor	Abnormal sound inside the compressor	If add too much refrigerant during maintenance, please reduce refrigerant properly. Replace compressor for other circumstances.

10. Exploded View and Parts List

10.1 Indoor Unit

For some models:

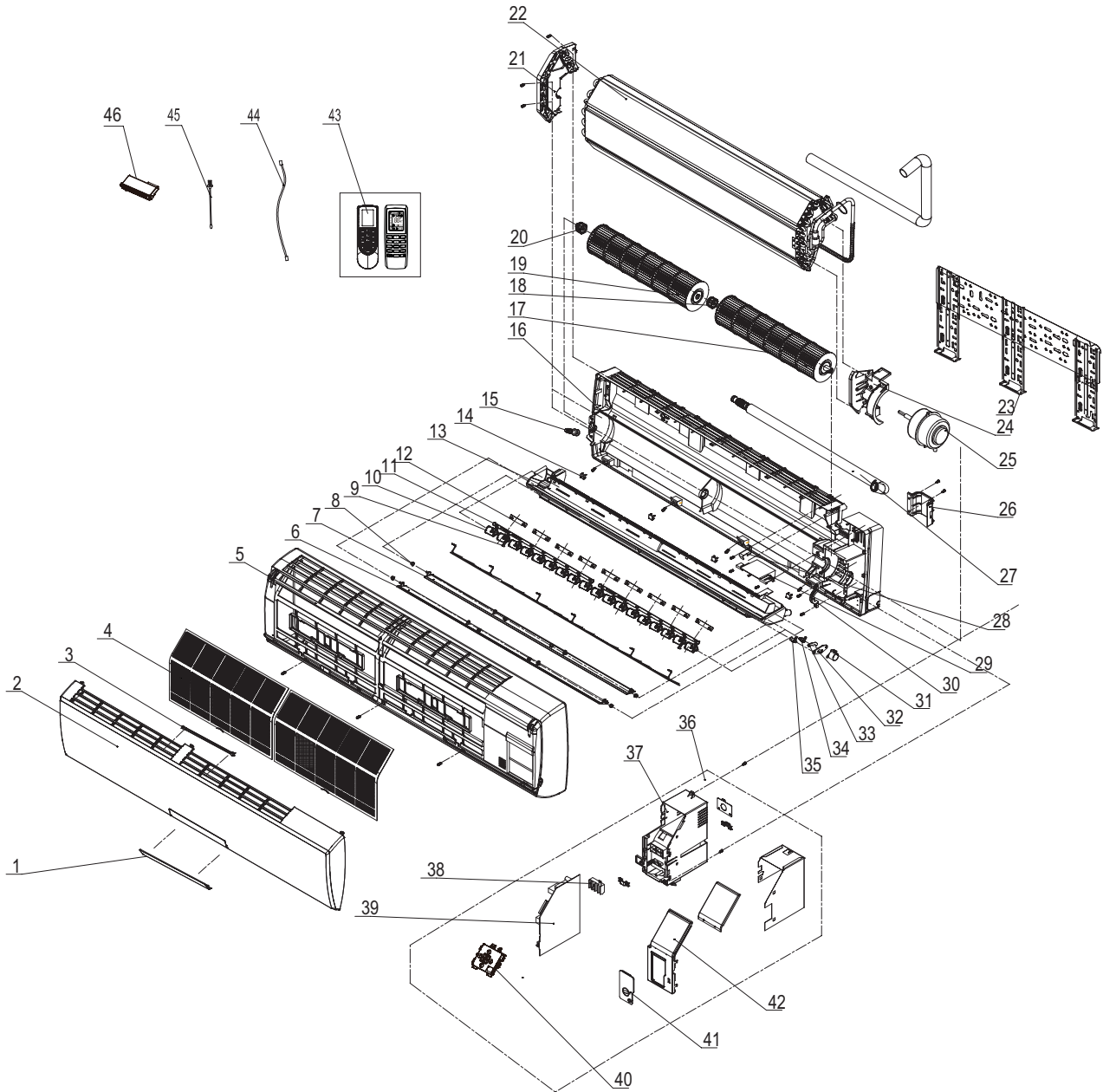

The component picture is only for reference; please refer to the actual product.

NO.	Description	Part Code		Qty
			VIR30HP230V1BH	
	Product Code		CB433N00202	
1	Receiver Window		/	/
2	Front Panel		20000300022S	1
3	Stand bar		2421212001	1
4	Filter Sub-Assy		11122106	2
5	Front Case Sub-Assy		20900700005	1
6	Upper Guide Louver		1051216601	1
7	Lower guide louver		1051216701	1
8	Axile Bush		10542704	6
9	Air Louver 2		1051216902	2
10	Air Louver 1		1051216802	16
11	Connecting Rod		10582086	2
12	Louver Clamp		26112158	9
13	Water Tray		2018213802	1
14	Screw Cover		2425200506	4
15	Rubber Plug (Water Tray)		76712012	1
16	Rear Case Sub-Assy		00000100113	1
17	Cross Flow Fan 1		10352039	1
18	Bearing Holder sub-assy		26152028	1
19	Cross Flow Fan 2		10352040	1
20	O-Gasket sub-assy of Bearing		76512051	1
21	Left Evaporator Support		24212041	1
22	Evaporator Assy		01002000027	1
23	Wall Mounting Frame		01252398	1
24	Right Support of Evaporator		2421204201	1
25	Fan Motor		1501213401	1
26	Pipe Clamp		26112071	1
27	Drainage hose		0523001404	1
28	Fixed Clip (Evaporator)		02112009	1
29	Cover Plate		2012212402	1
30	Motor Fixed Clip		26112324	1
31	Step Motor		1521210701	1
32	Press plate (crank)		26112070	1
33	Crank-guide		10582041	1
34	Upper Crank		10562004	1
35	Lower crank		10562005	1
36	Electric Box Assy		10000204113	1
37	Electric Box		201022502	1
38	Terminal Board		42011233	1
39	Main Board		30138001017	1
40	Display Board		30565277	1
41	Electric Box Cover		2011204404S	1
42	Electric Box Cover		201022523	1
43	Remote Controller		305001000085	1
44	Tube Sensor		390000592	1
45	Ambient Temperature Sensor		390000453	1
46	Detecting plate(WIFI)		30070077	1

Above data is subject to change without notice.

NO.	Description	Part Code		Qty
			VIR36HP230V1BH	
	Product Code		CB433N00402	
1	Receiver Window		/	/
2	Front Panel		20000300022S	1
3	Stand bar		2421212001	1
4	Filter Sub-Assy		11122106	2
5	Front Case Sub-Assy		20900700005	1
6	Upper Guide Louver		1051216601	1
7	Lower guide louver		1051216701	1
8	Axile Bush		10542704	6
9	Air Louver 2		1051216902	2
10	Air Louver 1		1051216802	16
11	Connecting Rod		10582086	2
12	Louver Clamp		26112158	9
13	Water Tray		2018213802	1
14	Screw Cover		2425200506	4
15	Rubber Plug (Water Tray)		76712012	1
16	Rear Case Sub-Assy		00000100113	1
17	Cross Flow Fan 1		10352039	1
18	Bearing Holder sub-assy		26152028	1
19	Cross Flow Fan 2		10352040	1
20	O-Gasket sub-assy of Bearing		76512051	1
21	Left Evaporator Support		24212041	1
22	Evaporator Assy		01002000027	1
23	Wall Mounting Frame		01252398	1
24	Right Support of Evaporator		2421204201	1
25	Fan Motor		1501213401	1
26	Pipe Clamp		26112071	1
27	Drainage hose		0523001404	1
28	Fixed Clip (Evaporator)		02112009	1
29	Cover Plate		2012212402	1
30	Motor Fixed Clip		26112324	1
31	Step Motor		1521210701	1
32	Press plate (crank)		26112070	1
33	Crank-guide		10582041	1
34	Upper Crank		10562004	1
35	Lower crank		10562005	1
36	Electric Box Assy		10000204114	1
37	Electric Box		201022502	1
38	Terminal Board		42011233	1
39	Main Board		30138001017	1
40	Display Board		30565277	1
41	Electric Box Cover		201022523	1
42	Electric Box Cover		2011204404S	1
43	Remote Controller		305001000085	1
44	Tube Sensor		390000592	1
45	Ambient Temperature Sensor		390000453	1
46	Detecting plate(WIFI)		30070077	1

Above data is subject to change without notice.

INTENTIONALLY BLANK

NO.	Description	Part Code		Qty
	Product Code			
1	Receiver Window			/
2	Front Panel			1
3	Stand bar			1
4	Filter Sub-Assy			2
5	Front Case Sub-Assy			1
6	Upper Guide Louver			1
7	Lower guide louver			1
8	Axile Bush			6
9	Air Louver 2			2
10	Air Louver 1			16
11	Connecting Rod			2
12	Louver Clamp			9
13	Water Tray			1
14	Screw Cover			4
15	Rubber Plug (Water Tray)			1
16	Rear Case Sub-Assy			1
17	Cross Flow Fan 1			1
18	Bearing Holder sub-assy			1
19	Cross Flow Fan 2			1
20	O-Gasket sub-assy of Bearing			1
21	Left Evaporator Support			1
22	Evaporator Assy			1
23	Wall Mounting Frame			1
24	Right Support of Evaporator			1
25	Fan Motor			1
26	Pipe Clamp			1
27	Drainage hose			1
28	Fixed Clip (Evaporator)			1
29	Cover Plate			1
30	Motor Fixed Clip			1
31	Step Motor			1
32	Press plate (crank)			1
33	Crank-guide			1
34	Upper Crank			1
35	Lower crank			1
36	Electric Box Assy			1
37	Electric Box			1
38	Terminal Board			1
39	Main Board			1
40	Display Board			1
41	Electric Box Cover			1
42	Electric Box Cover			1
43	Remote Controller			1
44	Tube Sensor			1
45	Ambient Temperature Sensor			1
46	Detecting plate(WIFI)			1

Above data is subject to change without notice.

INTENTIONALLY BLANK

NO.	Description	Part Code		Qty
1	Receiver Window			/
2	Front Panel			1
3	Stand bar			1
4	Filter Sub-Assy			2
5	Front Case Sub-Assy			1
6	Upper Guide Louver			1
7	Lower guide louver			1
8	Axile Bush			6
9	Air Louver 2			2
10	Air Louver 1			16
11	Connecting Rod			2
12	Louver Clamp			9
13	Water Tray			1
14	Screw Cover			4
15	Rubber Plug (Water Tray)			1
16	Rear Case Sub-Assy			1
17	Cross Flow Fan 1			1
18	Bearing Holder sub-assy			1
19	Cross Flow Fan 2			1
20	O-Gasket sub-assy of Bearing			1
21	Left Evaporator Support			1
22	Evaporator Assy			1
23	Wall Mounting Frame			1
24	Right Support of Evaporator			1
25	Fan Motor			1
26	Pipe Clamp			1
27	Drainage hose			1
28	Fixed Clip (Evaporator)			1
29	Cover Plate			1
30	Motor Fixed Clip			1
31	Step Motor			1
32	Press plate (crank)			1
33	Crank-guide			1
34	Upper Crank			1
35	Lower crank			1
36	Electric Box Assy			1
37	Electric Box			1
38	Terminal Board			1
39	Main Board			1
40	Display Board			1
41	Electric Box Cover			1
42	Electric Box Cover			1
43	Remote Controller			1
44	Tube Sensor			1
45	Ambient Temperature Sensor			1
46	Detecting plate(WIFI)			1

Above data is subject to change without notice.

INTENTIONALLY BLANK

NO.	Description	Part Code		Qty
	Product Code			
1	Receiver Window			/
2	Front Panel			1
3	Stand bar			1
4	Filter Sub-Assy			2
5	Front Case Sub-Assy			1
6	Upper Guide Louver			1
7	Lower guide louver			1
8	Axile Bush			6
9	Air Louver 2			2
10	Air Louver 1			16
11	Connecting Rod			2
12	Louver Clamp			9
13	Water Tray			1
14	Screw Cover			4
15	Rubber Plug (Water Tray)			1
16	Rear Case Sub-Assy			1
17	Cross Flow Fan 1			1
18	Bearing Holder sub-assy			1
19	Cross Flow Fan 2			1
20	O-Gasket sub-assy of Bearing			1
21	Left Evaporator Support			1
22	Evaporator Assy			1
23	Wall Mounting Frame			1
24	Right Support of Evaporator			1
25	Fan Motor			1
26	Pipe Clamp			1
27	Drainage hose			1
28	Fixed Clip (Evaporator)			1
29	Cover Plate			1
30	Motor Fixed Clip			1
31	Step Motor			1
32	Press plate (crank)			1
33	Crank-guide			1
34	Upper Crank			1
35	Lower crank			1
36	Electric Box Assy			1
37	Electric Box			1
38	Terminal Board			1
39	Main Board			1
40	Display Board			1
41	Electric Box Cover			1
42	Electric Box Cover			1
43	Remote Controller			1
44	Tube Sensor			1
45	Ambient Temperature Sensor			1
46	Detecting plate(WIFI)			1

Above data is subject to change without notice.

VIRU36HP230V1AH VIRU30HP230V1AH LIVS36HP230V1CH
 VIR36HP230V1CH LIVV30HP230V1AH

LIVV36HP230V1AH

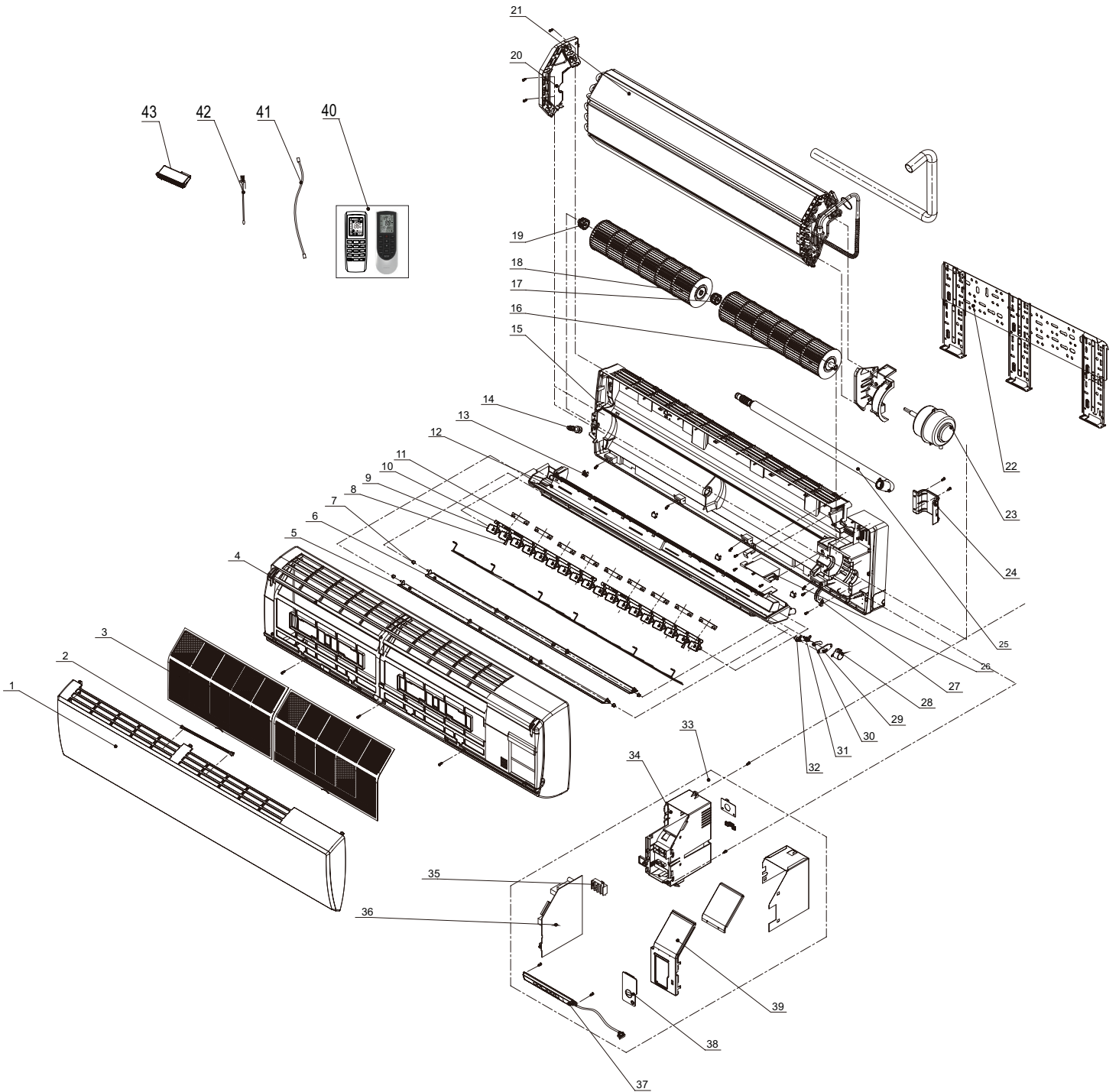

The component picture is only for reference; please refer to the actual product.

NO.	Description	Part Code			Qty
		VIRU36HP230V1AH	VIRU30HP230V1AH		
		Product Code	CB432N10100	CB432N10000	
1	Front Panel	20000300022S	20000300022S		1
2	Stand Bar	2421212001	2421212001		1
3	Filter Sub-Assy	1112210601	1112210602		2
4	Front Case Sub-assy	20900700005	20900700005		1
5	Upper Guide Louver	1051216601	1051216601		1
6	Lower Guide Louver	1051216701	1051216701		1
7	Axile Bush	10542704	10542704		6
8	Air Louver 2	1051216902	1051216902		2
9	Air Louver 1	1051216802	1051216802		16
10	Connecting Rod	10582086	10582086		2
11	Louver Clamp	26112158	26112158		9
12	Water Tray	2018213802	2018213802		1
13	Screw Cover	2425200506	2425200506		4
14	Rubber Plug (Water Tray)	76712012	76712012		1
15	Rear Case assy	00000100113	00000100113		1
16	Cross Flow Fan 1	10352039	10352039		1
17	Bearing Holder Sub-assy	26152028	26152028		1
18	Cross Flow Fan 2	10352040	10352040		1
19	O-Gasket sub-assy of Bearing	76512051	76512051		1
20	Left Evaporator Support	24212041	24212041		1
21	Evaporator Assy	01100100014001	01100100014001		1
22	Wall Mounting Frame	01252398	01252398		1
23	Fan Motor	1501213401	1501213401		1
24	Pipe Clamp	26112071	26112071		1
25	Drainage Hose	0523001404	0523001404		1
26	Cover Plate	2012212402	2012212402		1
27	Motor Fixed Clip 1	26112324	26112324		1
28	SteppingMotor	1521210701	1521210701		1
29	Press Plate(Crank)	26112070	26112070		1
30	Crank-guide	10582041	10582041		1
31	Upper Crank	10562004	10562004		1
32	Lower crank	10562005	10562005		1
33	Electric Box Assy	100002003292	100002003292		1
34	Electric Box	201022502	201022502		1
35	Terminal Board	42011233	42011233		1
36	Main Board	30138001017	30138001017		1
37	Display Board	30565277	30565277		1
38	Electric Box Cover	201022523	201022523		1
39	Electric Box Cover	2011204404S	2011204404S		1
40	Remote Controller	305001000085	305001000085		1
41	Temperature Sensor	390000592	390000592		1
42	Temperature Sensor	390000453	390000453		1
43	Detecting plate(WIFI)	30070077	30070077		1

Above data is subject to change without notice.

NO.	Description	Part Code			Qty
		VIR36HP230V1CH	LIVS36HP230V1CH		
		Product Code			
1	Front Panel	20000300022S	20000300022S		1
2	Stand Bar	2421212001	2421212001		1
3	Filter Sub-Assy	11122106	1112210602		2
4	Front Case Sub-assy	20900700005	20900700005		1
5	Upper Guide Louver	1051216601	1051216601		1
6	Lower Guide Louver	1051216701	1051216701		1
7	Axile Bush	10542704	10542704		6
8	Air Louver 2	1051216902	1051216902		2
9	Air Louver 1	1051216802	1051216802		16
10	Connecting Rod	10582086	10582086		2
11	Louver Clamp	26112158	26112158		9
12	Water Tray	2018213802	2018213802		1
13	Screw Cover	2425200506	2425200506		4
14	Rubber Plug (Water Tray)	76712012	76712012		1
15	Rear Case assy	00000100113	00000100113		1
16	Cross Flow Fan 1	10352039	10352039		1
17	Bearing Holder Sub-assy	26152028	26152028		1
18	Cross Flow Fan 2	10352040	10352040		1
19	O-Gasket sub-assy of Bearing	76512051	76512051		1
20	Left Evaporator Support	24212041	24212041		1
21	Evaporator Assy	1002000027	01002000027		1
22	Wall Mounting Frame	1252398	01252398		1
23	Fan Motor	1501213401	1501213401		1
24	Pipe Clamp	26112071	26112071		1
25	Drainage Hose	523001404	0523001404		1
26	Cover Plate	2012212402	2012212402		1
27	Motor Fixed Clip 1	26112324	26112324		1
28	Stepping Motor	1521210701	1521210701		1
29	Press Plate(Crank)	26112070	26112070		1
30	Crank-guide	10582041	10582041		1
31	Upper Crank	10562004	10562004		1
32	Lower crank	10562005	10562005		1
33	Electric Box Assy	100002001022	100002064434		1
34	Electric Box	201022502	201022502		1
35	Terminal Board	42011233	42011233		1
36	Main Board	30138001017	30138001017		1
37	Display Board	30565277	30565277		1
38	Electric Box Cover	2011204404S	2011204404S		1
39	Electric Box Cover	2011204404	2011204404		1
40	Remote Controller	305001000085	305001000085		1
41	Temperature Sensor	390000592	390000592		1
42	Temperature Sensor	390000453	390000453		1
43	Detecting plate(WIFI)	30070077	30070077		1

Above data is subject to change without notice.

NO.	Description	Part Code		Qty
			LIVV30HP230V1AH	
	Product Code		CB432N22100	
1	Front Panel		20000300022S	1
2	Stand Bar		2421212001	1
3	Filter Sub-Assy		1112210602	2
4	Front Case Sub-assy		20900700005	1
5	Upper Guide Louver		1051216601	1
6	Lower Guide Louver		1051216701	1
7	Axile Bush		10542704	6
8	Air Louver 2		1051216902	2
9	Air Louver 1		1051216802	16
10	Connecting Rod		10582086	2
11	Louver Clamp		26112158	9
12	Water Tray		2018213802	1
13	Screw Cover		2425200506	4
14	Rubber Plug (Water Tray)		76712012	1
15	Rear Case assy		00000100113	1
16	Cross Flow Fan 1		10352040	1
17	Bearing Holder Sub-assy		26152028	1
18	Cross Flow Fan 2		10352039	1
19	O-Gasket sub-assy of Bearing		76512051	1
20	Left Evaporator Support		24212041	1
21	Evaporator Assy		01100100299	1
22	Wall Mounting Frame		01252398	1
23	Fan Motor		1501213401	1
24	Pipe Clamp		26112071	1
25	Drainage Hose		0523001404	1
26	Cover Plate		2012212402	1
27	Motor Fixed Clip 1		26112324	1
28	SteppingMotor		1521210701	1
29	Press Plate(Crank)		26112070	1
30	Crank-guide		10582041	1
31	Upper Crank		10562004	1
32	Lower crank		10562005	1
33	Electric Box Assy		100002003292	1
34	Electric Box		2010225006	1
35	Terminal Board		42011233	1
36	Main Board		30138001017	1
37	Display Board		30565277	1
38	Electric Box Cover		2011204404S	1
39	Electric Box Cover		201022523	1
40	Remote Controller		305001000085	1
41	Temperature Sensor		390000453	1
42	Temperature Sensor		390000592	1
43	Detecting plate(WIFI)		30070077	1

Above data is subject to change without notice.

NO.	Description	Part Code			Qty
			LIVV36HP230V1AH		
		Product Code	CB432N23000		
1	Front Panel		20000300022S		1
2	Stand Bar		2421212001		1
3	Filter Sub-Assy		1112210602		2
4	Front Case Sub-assy		20900700005		1
5	Upper Guide Louver		1051216601		1
6	Lower Guide Louver		1051216701		1
7	Axile Bush		10542704		6
8	Air Louver 2		1051216902		2
9	Air Louver 1		1051216802		16
10	Connecting Rod		10582086		2
11	Louver Clamp		26112158		9
12	Water Tray		2018213802		1
13	Screw Cover		2425200506		4
14	Rubber Plug (Water Tray)		76712012		1
15	Rear Case assy		00000100113		1
16	Cross Flow Fan 1		10352040		1
17	Bearing Holder Sub-assy		26152028		1
18	Cross Flow Fan 2		10352039		1
19	O-Gasket sub-assy of Bearing		76512051		1
20	Left Evaporator Support		24212041		1
21	Evaporator Assy		0110010029901		1
22	Wall Mounting Frame		01252398		1
23	Fan Motor		1501213401		1
24	Pipe Clamp		26112071		1
25	Drainage Hose		0523001404		1
26	Cover Plate		2012212402		1
27	Motor Fixed Clip 1		26112324		1
28	SteppingMotor		1521210701		1
29	Press Plate(Crank)		26112070		1
30	Crank-guide		10582041		1
31	Upper Crank		10562004		1
32	Lower crank		10562005		1
33	Electric Box Assy		100002003292		1
34	Electric Box		2010225006		1
35	Terminal Board		42011233		1
36	Main Board		30138001017		1
37	Display Board		30565277		1
38	Electric Box Cover		2011204404S		1
39	Electric Box Cover		201022523		1
40	Remote Controller		305001000085		1
41	Temperature Sensor		390000453		1
42	Temperature Sensor		390000592		1
43	Detecting plate(WIFI)		30070077		1

Above data is subject to change without notice.

10.2 Outdoor Unit

INTENTIONALLY BLANK

NO.	Description	Product Code			Qty
1	Front Grill				1
2	Cabinet				1
3	Front Side Plate				1
4	Axial Flow Fan				1
5	Chassis Sub-assy				1
6	Compressor Gasket				3
7	Compressor and Fittings				1
8	Discharge Tube Sub-assy				1
9	Inhalation Tube Sub-assy				1
10	Right Side Plate				1
11	Valve Support Sub-Assy				1
12	Cut off Valve				1
13	Valve Cover				1
14	Retaining plate				1
15	Handle assy				1
16	Wiring clamp				1
17	Electric Expansion Valve Sub-Assy				1
18	Temperature Sensor				1
19	Rear Grill				1
20	Condenser Assy				1
21	Clapboard				1
22	Condenser support plate				1
23	Motor Support Sub-Assy				1
24	Top Cover Sub-Assy				1
25	Electric Box Cover				1
26	Reactor				2
27	Electric Box Sub-Assy				1
28	Pass wire ring sub-assy				2
29	left handle				1
30	Left Side Plate				1
31	Fan Motor				1
32	Electric Box Cover				1
33	Main Board				1
34	Electric Box				1
35	Radiator				1
36	Terminal Board				1
37	Electric Box Assy				1

Above data is subject to change without notice.

INTENTIONALLY BLANK

NO.	Description	Product Code	Qty
		Product Code	
1	Front Grill		1
2	Cabinet		1
3	Front Side Plate		1
4	Axial Flow Fan		1
5	Chassis Sub-assy		1
6	Compressor Gasket		3
7	Compressor and Fittings		1
8	Discharge Tube Sub-assy		1
9	Inhalation Tube Sub-assy		1
10	Right Side Plate		1
11	Valve Support Sub-Assy		1
12	Cut off Valve		1
13	Valve Cover		1
14	Retaining plate		1
15	Handle assy		1
16	Wiring clamp		1
17	Electric Expansion Valve Sub-Assy		1
18	Temperature Sensor		1
19	Rear Grill		1
20	Condenser Assy		1
21	Clapboard		1
22	Condenser support plate		1
23	Motor Support Sub-Assy		1
24	Top Cover Sub-Assy		1
25	Electric Box Cover		1
26	Reactor		/
27	Electric Box Sub-Assy		1
28	Pass wire ring sub-assy		/
29	left handle		1
30	Left Side Plate		1
31	Fan Motor		1
32	Electric Box Cover		1
33	Main Board		1
34	Electric Box		1
35	Radiator		1
36	Terminal Board		1
37	Electric Box Assy		1

Above data is subject to change without notice.

VIR36HP230V1CO LIVS36HP230V1CO LIVV30HP230V1AO
LIVV36HP230V1AO

VIR30HP230V1BO VIR36HP230V1BO

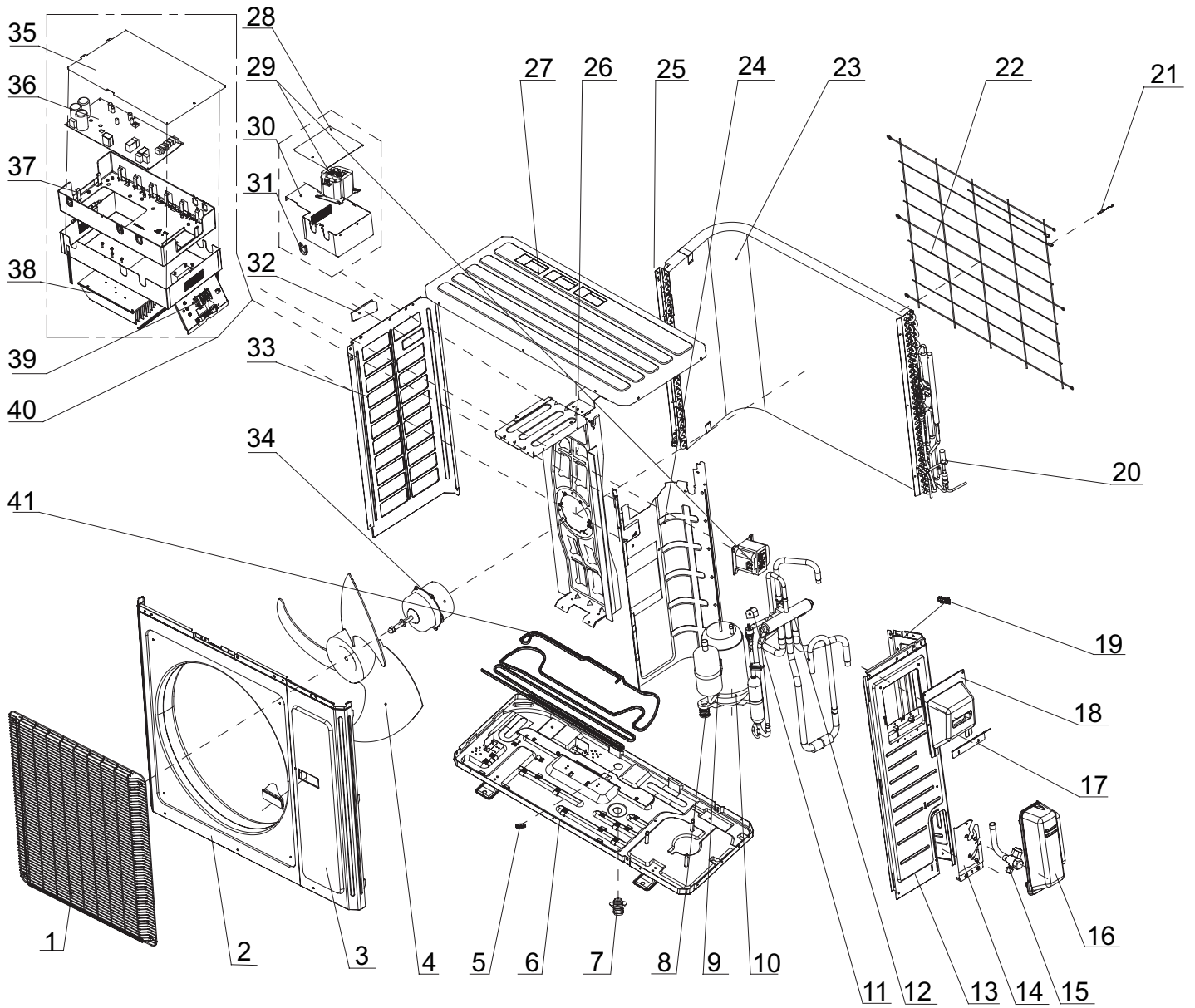

The component picture is only for reference; please refer to the actual product.

NO.	Description	Part Code			Qty
		VIR36HP230V1CO	LIVS36HP230V1CO	LIVV30HP230V1AO	
	Product Code	CB432W08100	CB432W20300	CB432W22100	
1	Front Grill	1473050	016004060005	016004060005	1
2	Cabinet	0143500401P	0143500401P	0143500401P	1
3	Front Side Plate	01303249P	01303249P	01303249P	1
4	Axial Flow Fan	10335014	10335014	10335014	1
5	Drainage Plug	7671301802	7671301802	/	1
6	Chassis Sub-assy	0280319605	0280319605	017000060476	1
7	Drainage Connector	06123401	06123401	/	1
8	Compressor Gasket	76713066	76713066	009012000004	3
9	Compressor and fittings	205200003	00205200003	00900100019501	1
10	Electrical heater	7651000413	7651000413	/	1
11	Magnet Coil	4300040029	4300040029	4300040045	1
12	4-way Valve Assy	30152000213	030152000213	030152000329	1
13	Right Side Plate	0130504402P	0130504402P	0130504402P	1
14	Valve Support Sub-Assy	0171501201P	0171501201P	0171501201P	1
15	Cut-off Valve	07130239	07130239	07130239	1
16	Valve cover	22245003	22245003	22245003	1
17	Retaining plate	02115006P	02115006P	02115006P	1
18	Handle assy	2113109	02113109	02113109	1
19	Wiring clamp	26115004	26115004	26115004	1
20	Electronic expansion valve Sub-Assy	07133684	07133684	030174060043	1
21	Temperature Sensor	3900031001	3900031001	3900030901	1
22	Rear Grill	01475013	01475013	01475013	1
23	Condenser Assy	01163491	01163491	01100200162	1
24	Clapboard	01233134	01233134	01235089	1
25	Condenser support plate	01175037	01175037	01175092	1
26	Motor Support Sub-Assy	01802876	01802876	017012000017	1
27	Top Cover Sub-Assy	1255007	000051000024	000051060049	1
28	Electric Box Cover	01425281	01425281	20125002	1
29	Reactor	43130192	43130192	/	2
30	Electric Box Sub-Assy	02603620	02603620	20115003	1
31	Pass wire ring sub-assy	76614102	76614102	/	2
32	left handle	2113031	02113031	02113031	1
33	Left Side Plate	01305043P	01305043	01305043P	1
34	Fan Motor	1570280000405	1570280000405	15010400000102	1
35	Electric Box Cover	01425281	01425281	20125002	1
36	Main Board	300027000216	300027000216	300027060960	1
37	Electric Box	02603614	02603614	20115003	1
38	Radiator	49010252	49010252	4901521502	1
39	Terminal Board	42200006001401	42200006001401	42200006001401	1
40	Electric Box Assy	100002001028	100002001028	100002067584	1
41	Electrical Heater (Chassis)	7651000413	7651000413	/	1

Above data is subject to change without notice.

NO.	Description	Part Code			Qty
		VIR30HP230V1BO	VIR36HP230V1BO	LIVV36HP230V1AO	
	Product Code	CB171W10600	CB171W10800	CB432W23000	
1	Front Grill	01473050	01473050	016004060005	1
2	Cabinet	0143500401P	0143500401P	0143500401P	1
3	Front Side Plate	01303249P	01303249P	01303249P	1
4	Axial Flow Fan	10335014	10335014	10335014	1
5	Drainage Plug	06813401	7671301802	/	1
6	Chassis Sub-assy	02803101P	02803026P	017000060476	1
7	Drainage Connector	06123401	06123401	/	1
8	Compressor Gasket	76715022	76710207	009012000004	3
9	Compressor and fittings	00105051	00205275	00900100019501	1
10	Electrical heater	7651873209	7651873209	/	1
11	Magnet Coil	4300040029	4300040029	4300040045	1
12	4-way Valve Assy	03123895	03123890	030152000329	1
13	Right Side Plate	0130504402P	0130504402P	0130504402P	1
14	Valve Support Sub-Assy	0171501201P	0171501201P	0171501201P	1
15	Cut-off Valve	07133157	07133157	07133157	1
16	Valve cover	22245003	22245003	22245003	1
17	Retaining plate	02115006P	02115006P	02115006P	1
18	Handle assy	02113109	02113109	02113109	1
19	Wiring clamp	26115004	26115004	26115004	1
20	Electronic expansion valve Sub-Assy	07133688	07133684	030174060043	1
21	Temperature Sensor	3900031001	3900031001	3900030901	1
22	Rear Grill	01475013	01475013	01475013	1
23	Condenser Assy	01163509	01163491	011002061052	1
24	Clapboard	01233134	01233134	01175092	1
25	Condenser support plate	01175092	01175037	01175092	1
26	Motor Support Sub-Assy	0180287601	01802876	017012000017	1
27	Top Cover Sub-Assy	01255007	01255007	000051060049	1
28	Electric Box Cover	01425279	01425281	20125002	1
29	Reactor	43130192	43130192	/	2
30	Electric Box Sub-Assy	02603620	02603620	100002068354	1
31	Pass wire ring sub-assy	76614102	76614102	/	2
32	left handle	26233053	02113031	02113031	1
33	Left Side Plate	01305043P	01305043P	01305043	1
34	Fan Motor	15702802	1570280000405	15010400000102	1
35	Electric Box Cover	01425281	01425281	20125002	1
36	Main Board	30148338	30138000711	300027060993	1
37	Electric Box	02603614	02603614	20115003	1
38	Radiator	49010252	49010252	4901521502	1
39	Terminal Board	42200006001401	42200006001401	42200006001401	1
40	Electric Box Assy	02613050	10000100328	100002068354	1
41	Electrical Heater (Chassis)	765100047	7651000413	/	1

Above data is subject to change without notice.

VIRU36HP230V1AO VIRU30HP230V1AO

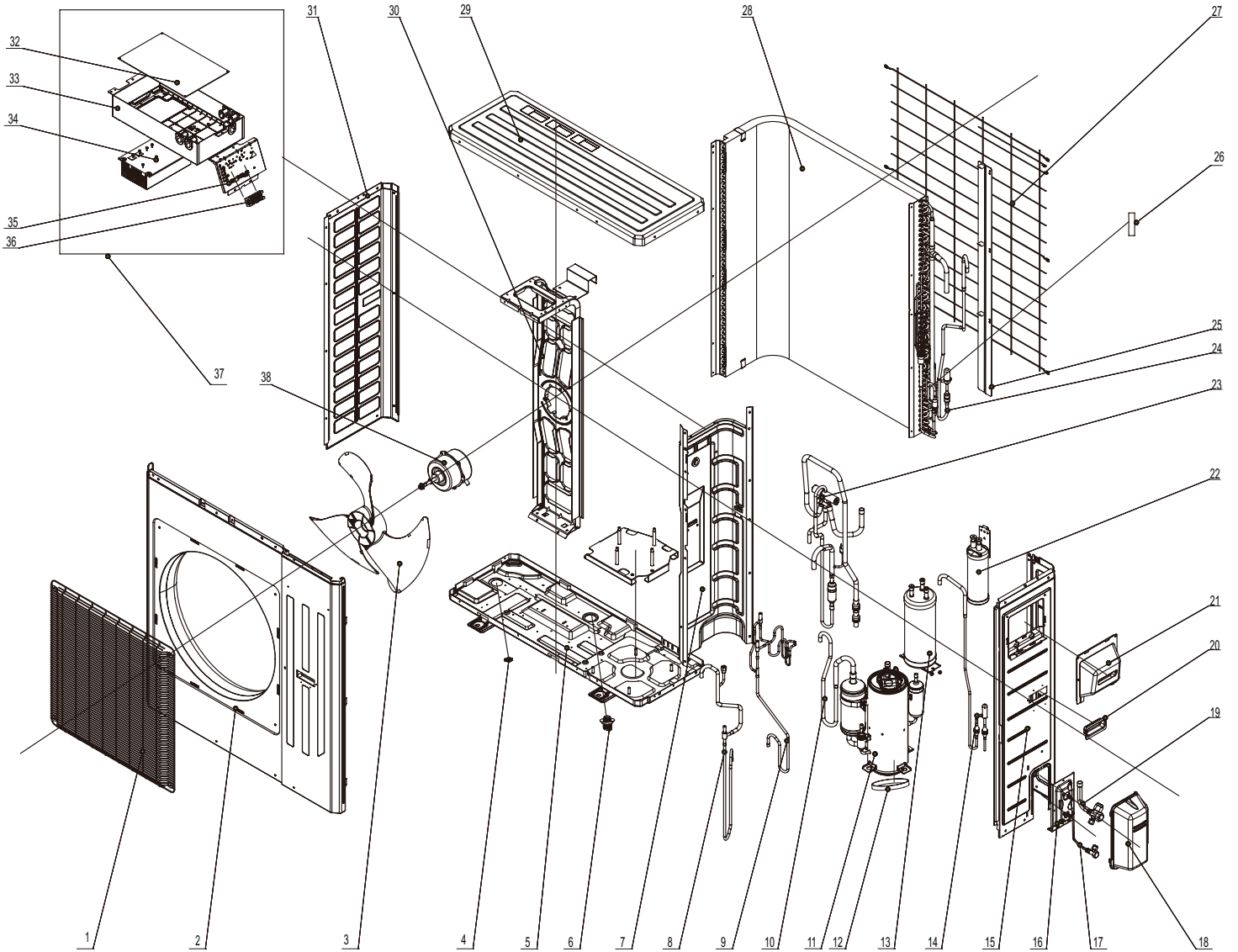

The component picture is only for reference; please refer to the actual product.

NO.	Description	Part Code		Qty
		VIRU36HP230V1AO	VIRU30HP230V1AO	
		Product Code	Product Code	
1	Front Grill	01574106	01574106	1
2	Cabinet	01435007P	01435007P	1
3	Axial Flow Fan	10335014	10335014	1
4	Drainage hole Cap	76715005	76715005	1
5	Electrical Heater (Chassis)	7651000413	7651000413	1
6	Drainage Joint	26113009	26113009	1
7	Clapboard Sub-Assy	0124525304	0124525304	1
8	Magnet Valve Sub-assy	030025000055	030025060028	1
9	Magnet Valve Sub-assy	030025000056	030025060027	1
10	Inhalation Tube Sub-assy	030010000570	030010060043	1
11	Compressor and Fittings	00204100030	009001000013	1
12	Electrical Heater(Compressor)	7651873209	7651873209	1
13	Accumulator	07424100031	07424100031	1
14	Electronic Expansion Valve assy B	030174000139	030174060018	1
15	Right side plate	017038000055	017038000055	1
16	Valve Support Sub-Assy	01805200222P	01805200222P	1
17	Cut off Valve Sub-Assy	030057000153	030057000153	1
18	Valve Cover	22245005	22245005	1
19	Cut off Valve	07133157	07133157	1
20	Handle	2623305301	2623305301	1
21	Handle Assy	02113109	02113032P	1
22	Gas-liquid Separator	07223048	07223048	1
23	4-Way Valve Assy	030152000370	030152060015	1
24	Baffle Plate Sub-assy	01355200016P	01355200016P	1
25	Electronic Expansion Valve assy A	030174000138	030174000138	1
26	Temperature Sensor	3900007201	3900007201	1
27	Rear Grill	01475012	01475012	1
28	Condenser Assy	011002000628	011002060047	1
29	Top Cover	0125500901P	0125500901P	1
30	Motor Support Sub-Assy	017012000155	017012000155	1
31	Left Side Plate	01305064P	01305064P	1
32	Main Board	300027000042	300027000519	1
33	Electric Box Sub-Assy	017007000632	017007000632	1
34	Radiator	43003400001601	43003400001601	1
35	Terminal Board Support sub-assy	01715016	01715016	1
36	Terminal Board	42000100000402	42000100000402	1
37	Electric Box Assy	100002003294	100002004090	1
38	Brushless DC Motor	15010400000106	15010400000106	1

Above data is subject to change without notice.

11. Removal Procedure



Warning: Be sure to wait for a minimum of 20 minutes after turning off all power supplies and discharge the refrigerant completely before removal.

11.1 Removal Procedure of Indoor Unit

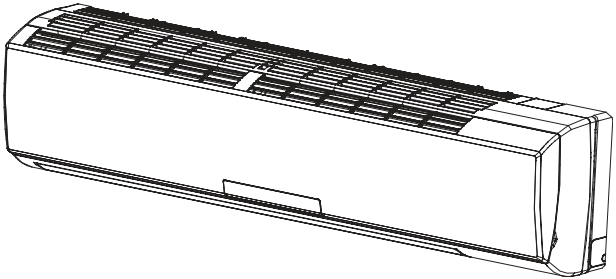
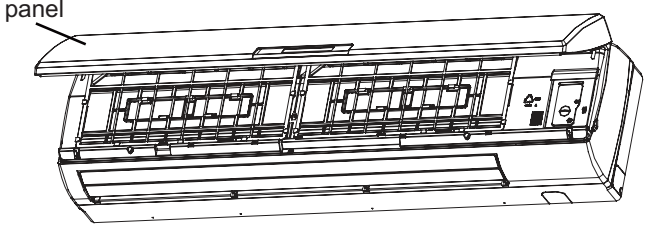
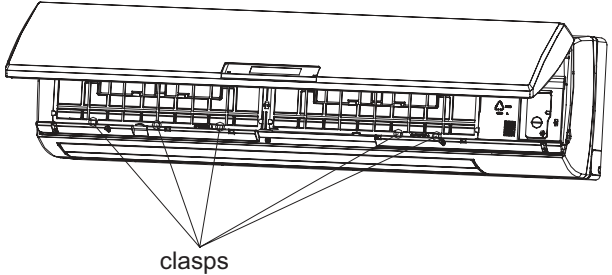
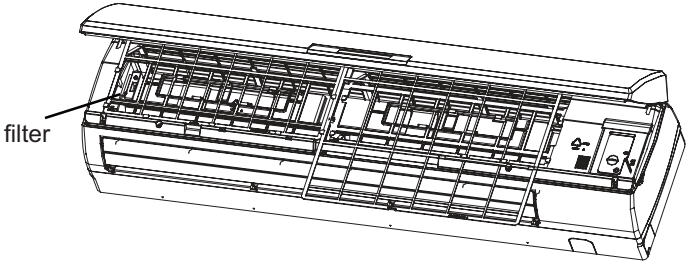
Steps	Procedure
1. Before disassembly of the unit	
	<p>Axonometric drawing for the complete unit.</p>
2. Remove filter	
a	<p>Open the panel.</p> 
b	<p>Loosen the clasps on the filter.</p> 
c	<p>Draw out two pieces of filter.</p> 

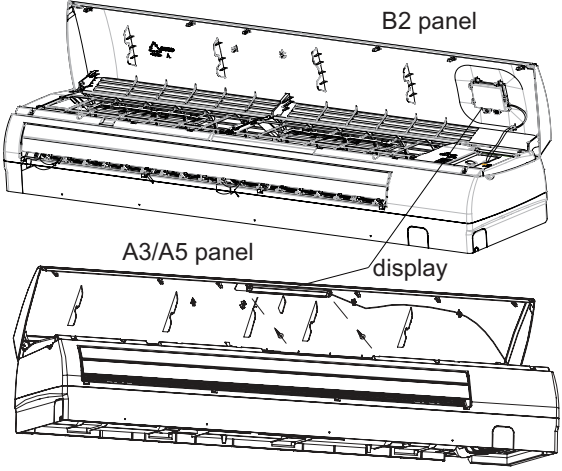
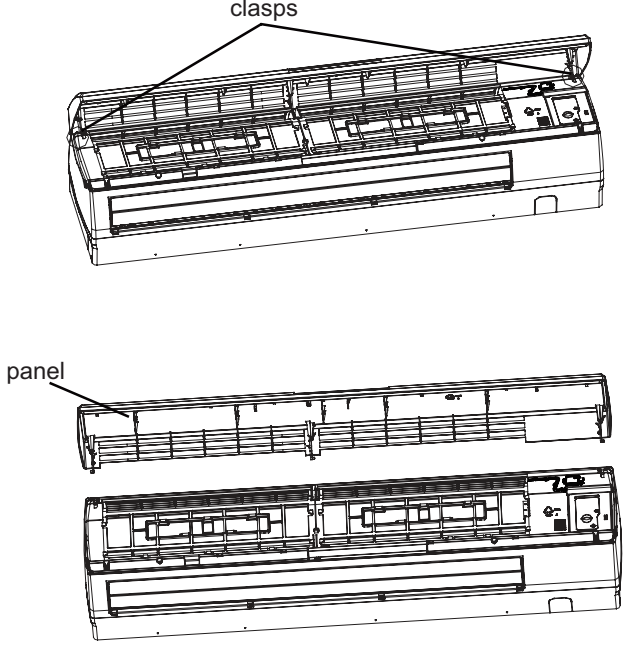
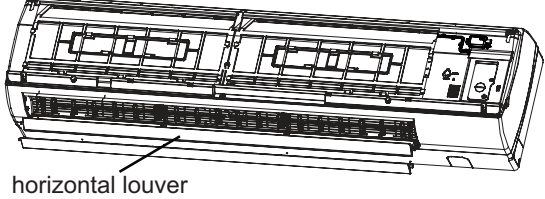
Steps	Procedure
3.Remove display	<p data-bbox="224 519 743 585">Remove screws fixing display, and then remove the display.</p> 
4.Remove panel	<p data-bbox="224 1137 711 1203">Pull the clasps at both sides slightly, and then remove the panel.</p> 
5.Remove horizontal louver	<p data-bbox="224 1793 743 1858">Remove the axial bush on the horizontal louver, and then remove the horizontal louver.</p> 

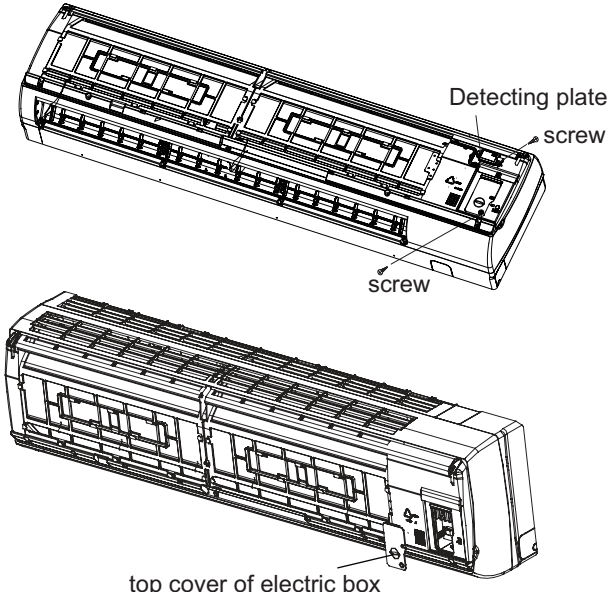
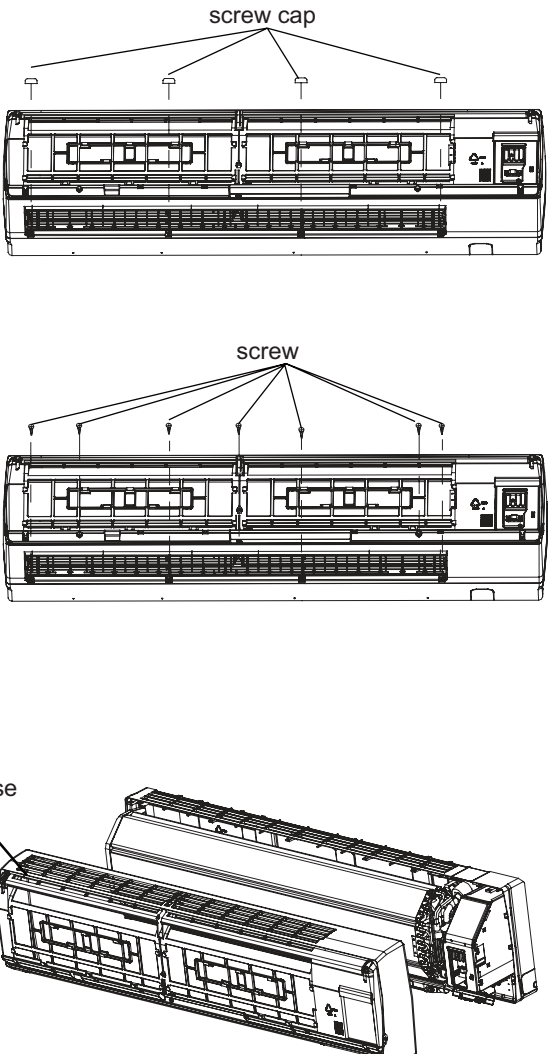
Steps	Procedure	
<p>6.Remove detecting plate and top cover of electric box</p> <p>a</p> <p>b</p>	<p>Remove the screw fixing detecting plate and then remove the detecting plate. Note:The position of detection board(WIFI) may be different for -different models.</p> <p>Remove screws fixing the top cover of electric box. Remove the top cover of electric box.</p>	
<p>7.Remove front case</p> <p>a</p> <p>b</p> <p>c</p>	<p>Remove the screw caps on front case.</p> <p>Remove screws connecting the front case.</p> <p>Remove the front case.</p>	

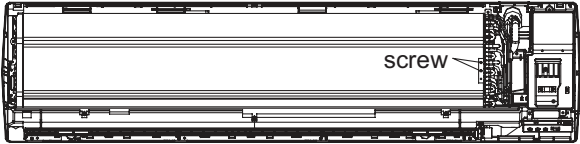
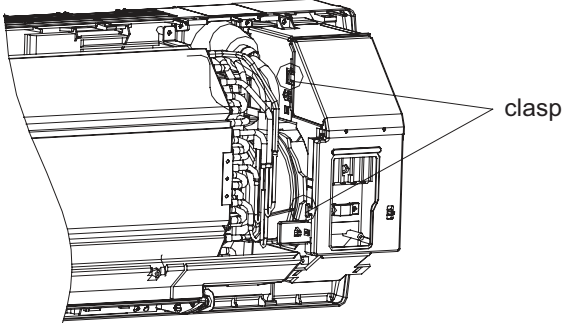
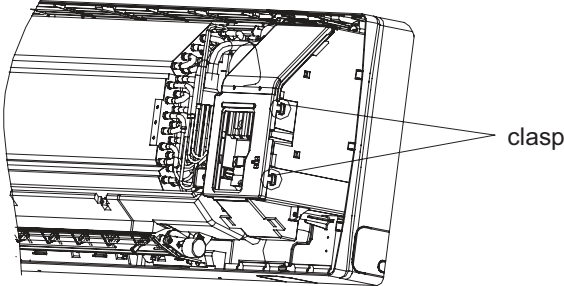
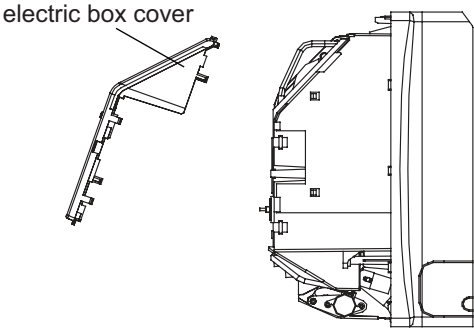
Steps	Procedure	
8.Remove earthing wire	Remove earthing screws, and then remove the earthing wire.	
9.Remove electric box cover	<p>a Loosen clasps at the left side of electric box.</p> <p>b Loosen clasps on the right side of electric box.</p> <p>b Remove electric box cover.</p>	  

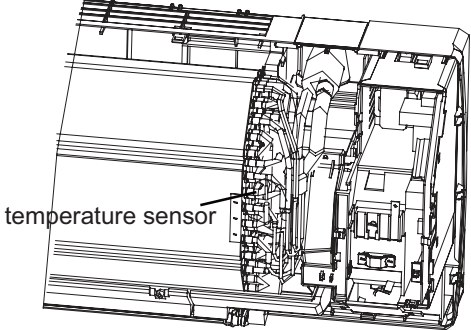
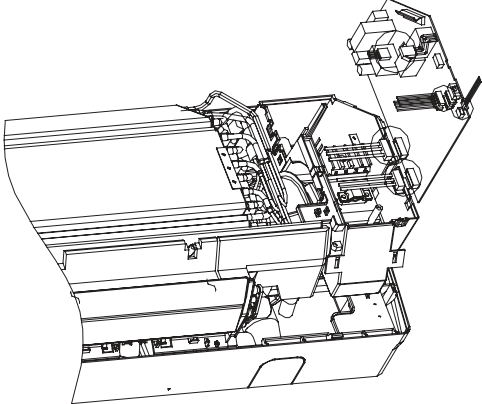
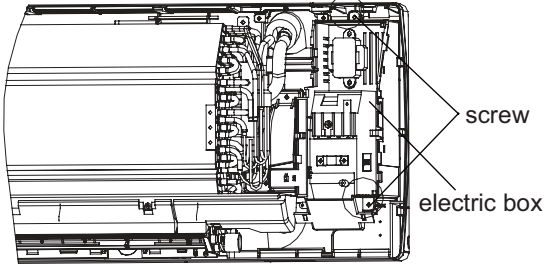
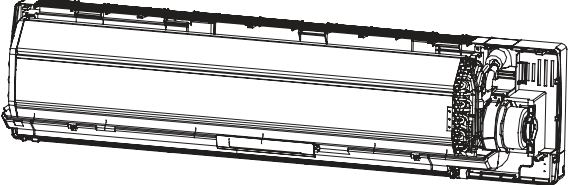
Steps	Procedure	
10.Remove temperature sensor		 <p>temperature sensor</p>
11.Remove electric box		
a	Pull out 6 sockets on PCB board.	
b	Pull out two screws on electric box.	 <p>screw</p> <p>electric box</p>
c	Remove the electric box.	

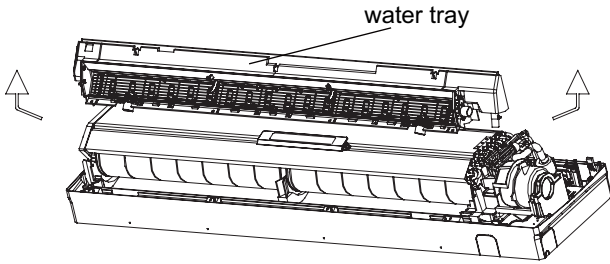
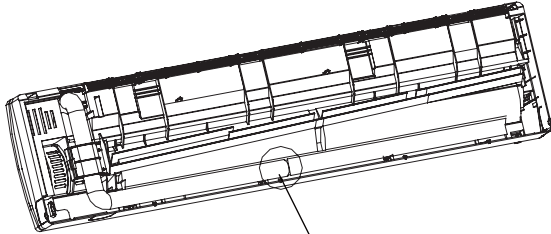
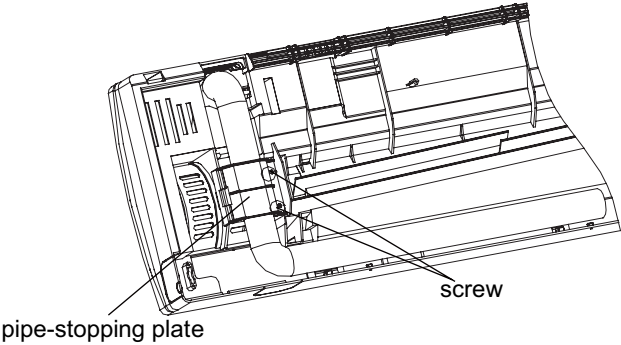
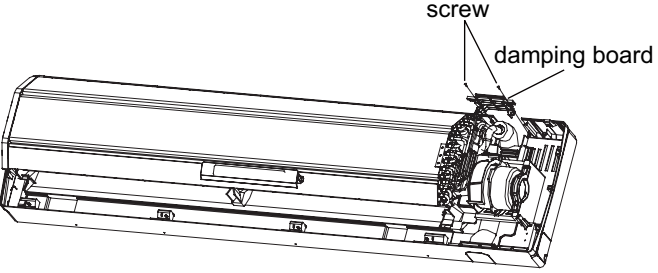
Steps	Procedure
12.Remove water tray	<p data-bbox="219 388 711 454">Pull the water tray upwards, and then remove the water tray.</p> 
13.Remove connection pipe between indoor and outdoor units	<p data-bbox="219 891 636 956">Separate the connection pipe between indoor and outdoor units.</p>  <p data-bbox="824 1033 1513 1065">connection position for indoor and outdoor units' connection pipe</p>
14.Remove pipe-stopping plate	<p data-bbox="219 1349 722 1437">Remove two screws on pipe-stopping plate for indoor unit, and then remove the pipe-stopping plate.</p>  <p data-bbox="815 1546 1019 1576">pipe-stopping plate</p> <p data-bbox="1253 1511 1318 1533">screw</p>
15.Remove damping board	<p data-bbox="219 1775 727 1841">Remove 2 screws on damping board, and then remove the damping board.</p>  <p data-bbox="1274 1655 1339 1677">screw</p> <p data-bbox="1339 1699 1507 1720">damping board</p>

Steps	Procedure
16.Remove evaporator	
a	Remove screws between evaporator and bottom case.
b	Turn over the indoor unit and adjust the pipe line to the position as shown by the broken line.
c	Lift up the evaporator, and then remove the evaporator.
17.Remove the fixing plate of motor	
	Remove 2 screws on fixing plate of motor, and then remove the fixing pate of motor.

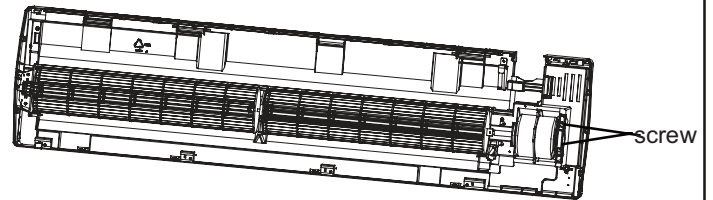
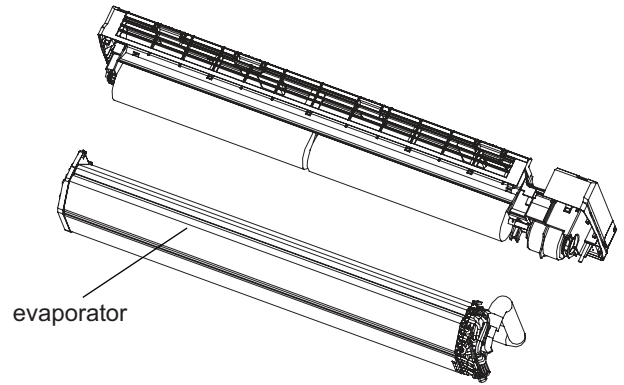
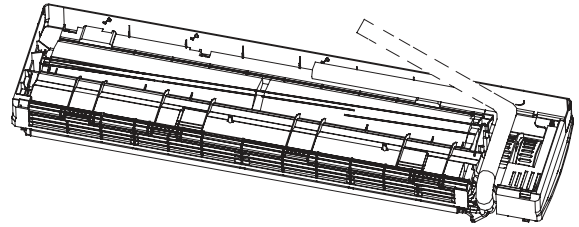
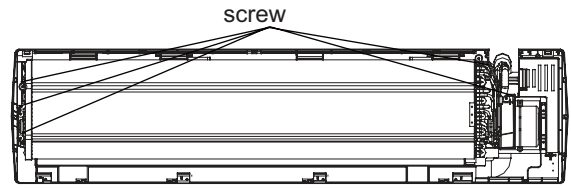

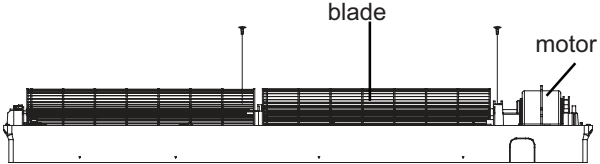
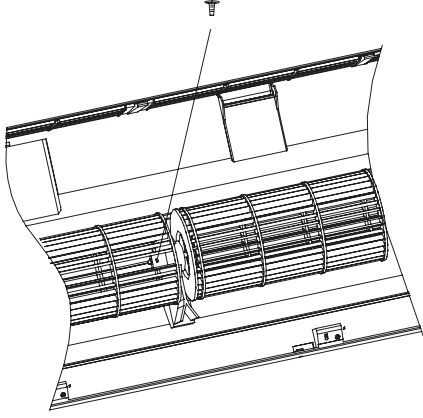
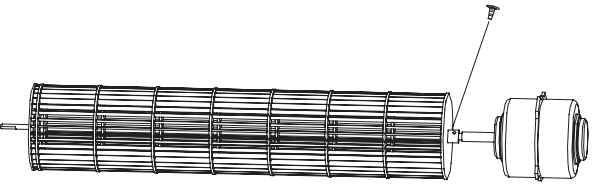
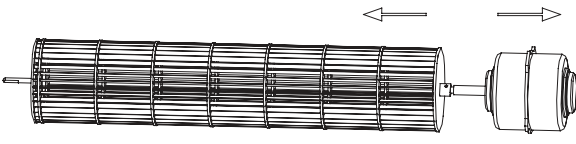
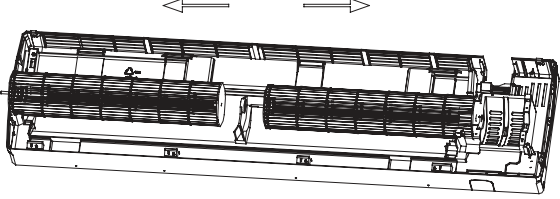
Steps	Procedure
18.Remove cross flow blade and motor	
a	<p>Remove screws fixing cross flow blade and motor.</p>   
b	<p>Remove the motor sub-assy.</p> 
c	<p>Separate two cross flow blade.</p> 

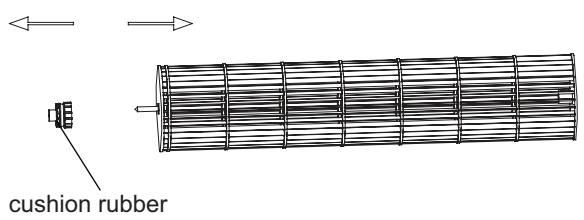
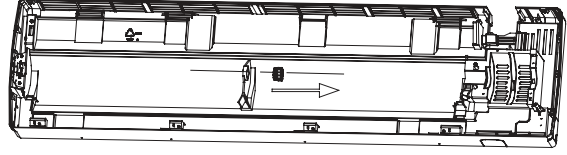
Steps	Procedure	
19.Remove cushion rubber		
a	Remove the cushion rubber on cross flow blade.	
b	Remove the cushion rubber from the base.	

11.2 Removal Procedure of Outdoor Unit

VIR30HP230V1BO

VIR36HP230V1BO

VIR36HP230V1CO LIVS36HP230V1CO

LIVV36HP230V1AO

Note: Take heat pump unit for example.

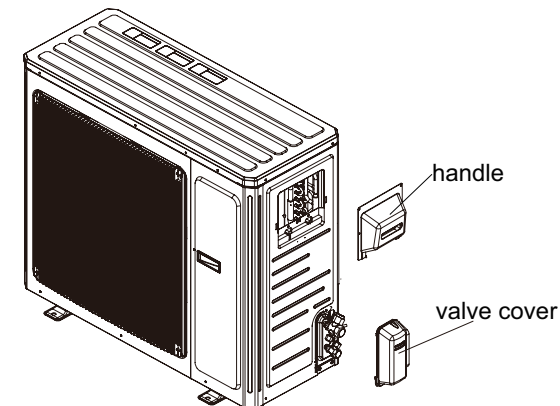
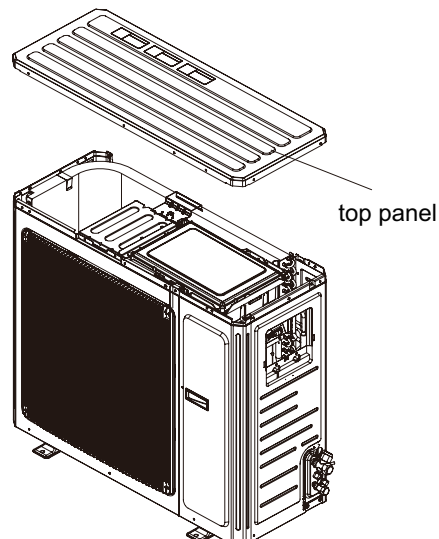
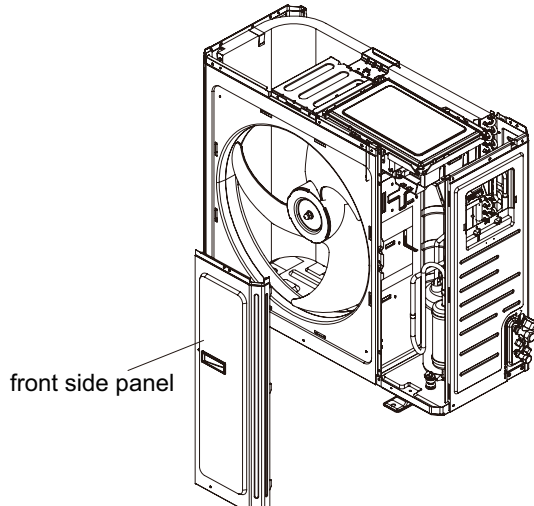
Steps	Procedure
1. Remove big handle, valve cover and top cover	<p data-bbox="186 535 730 666">Remove the screw connecting the big handle and right side plate, and then remove the big handle. Remove the screw connecting the valve cover and right side plate, and then remove the valve cover.</p> 
2. Remove top panel	<p data-bbox="186 1168 730 1255">Remove the screws connecting the top panel with the front panel and left&right side plate, and then remove the top panel.</p> 
3. Remove front side panel	<p data-bbox="186 1758 730 1845">Loosen the screws connecting the front side panel and chassis. Remove the front side panel.</p> 

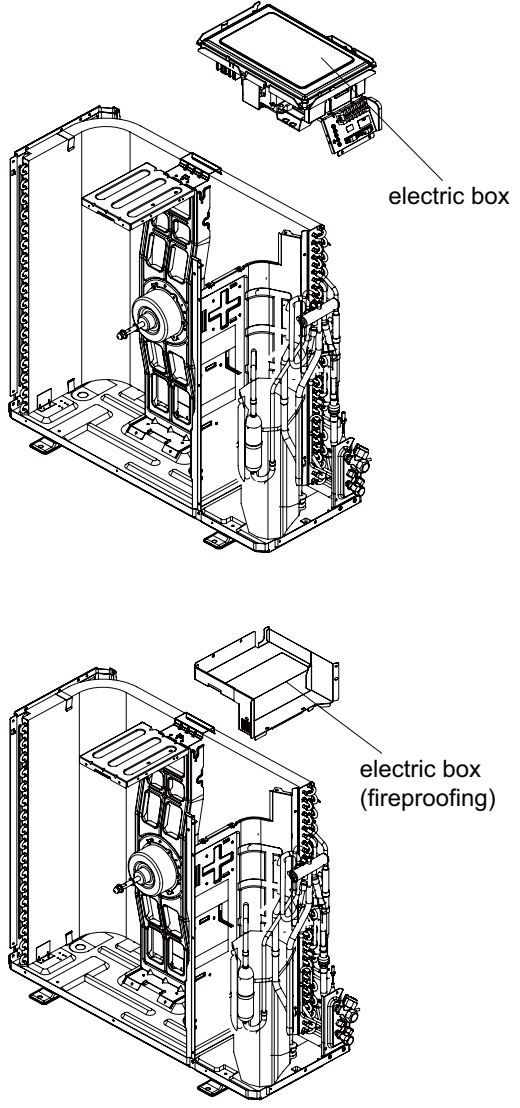
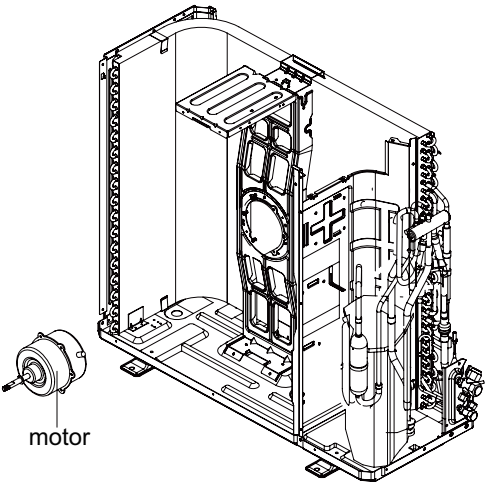
Steps	Procedure
<p>7.Remove electric box</p>	<p>Twist off the screws on electric box, cut off the tieline with scissors or pliers, pull out the wiring terminal, pull it upwards to remove the electric box.</p> <p>Twist off the screws on electric box (fireproofing) with screwdriver, and then remove the electric box (fireproofing).</p>  <p>The diagram consists of two parts. The top part shows a perspective view of the device with the electric box being removed. A label 'electric box' points to the box being pulled away. The bottom part shows the same device with the fireproofing box being removed. A label 'electric box (fireproofing)' points to the fireproofing box being pulled away.</p>
<p>8.Remove motor</p>	<p>Twist off the tapping screws fixing the motor, pull out the pin of leading wire for motor and then remove the motor.</p>  <p>The diagram shows a perspective view of the device with the motor being removed. A label 'motor' points to the motor being pulled out of the main assembly.</p>

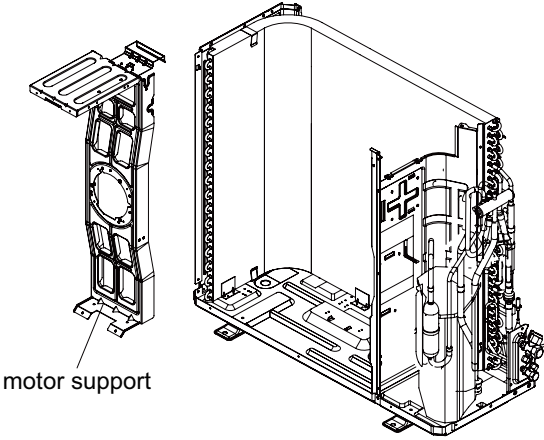
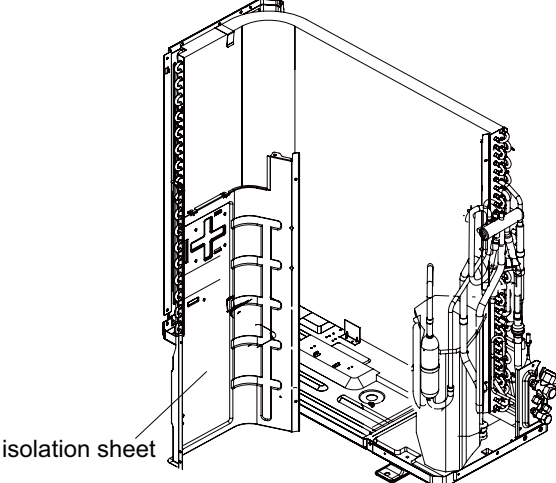
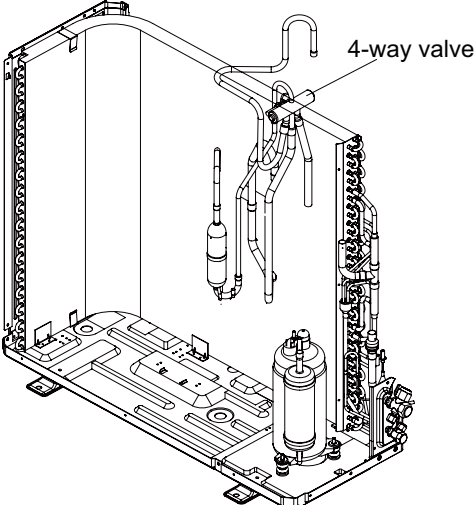
Steps	Procedure
9.Remove motor support	<p data-bbox="224 463 695 552">Twist off the tapping screws fixing the motor support, pull it upwards and then remove the motor support.</p> 
10.Remove isolation sheet	<p data-bbox="224 1052 722 1142">Twist off the screws connecting isolation sheet and end plate of condenser and chassis, and then remove the isolation sheet.</p> 
11.Remove 4-way valve	<p data-bbox="224 1589 690 1710">Unsolder the pipeline between compressor, condenser, gas and liquid valve, and then remove the 4-way valve. (note: release all refrigerant before unsoldering).</p> 

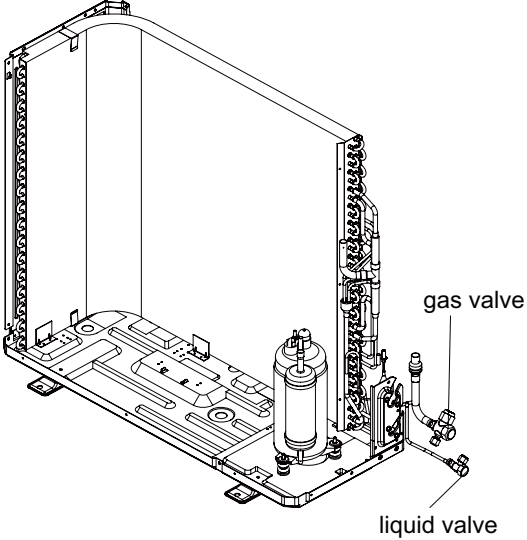
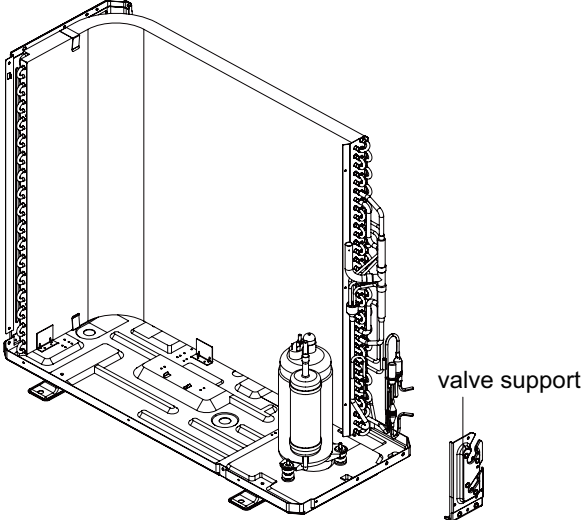
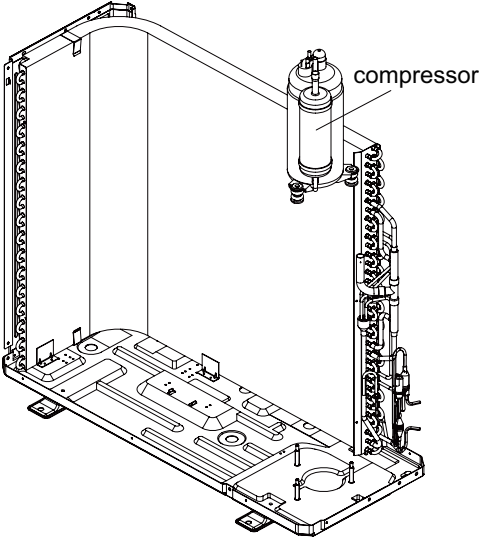
Steps	Procedure
12.Remove gas valve and liquid valve	<p>Twist off the 2 bolts fixing the valve sub-assy. Unsolder the soldering joint between gas valve and air-return pipe and then remove the gas valve.(note: when unsoldering the soldering joint, wrap the gas valve with wet cloth completely to avoid the damage to valve, and release all refrigerant completely at first). Unsolder the soldering joint between liquid valve and connection pipe of liquid valve, and then remove the liquid valve.</p> 
13.Remove valve support	<p>Twist off the screws connecting valve support and chassis, and then remove the valve support.</p> 
14.Remove compressor	<p>Twist off the 3 foot nuts on compressor and then remove the compressor.</p> 

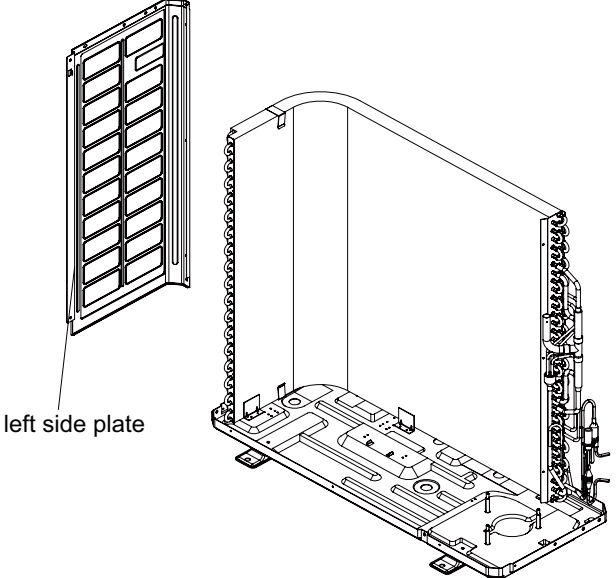
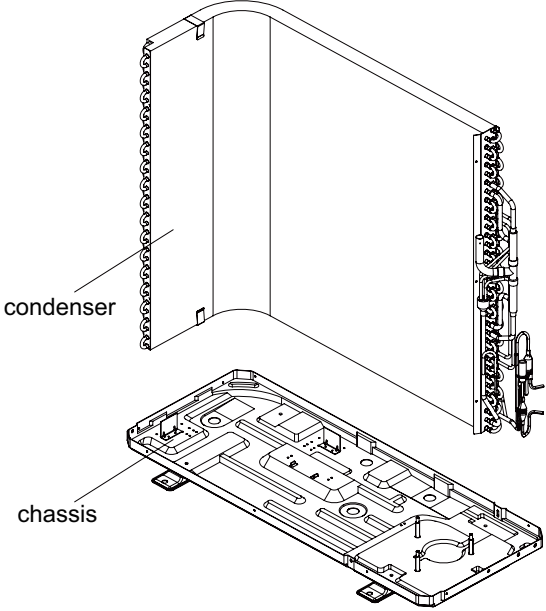
Steps	Procedure
15.Remove left side plate	<p data-bbox="215 410 743 497">Twist off the screws connecting the left side plate and chassis with screwdriver, and then remove the left side plate.</p> 
16.Remove chassis and condenser	<p data-bbox="215 1054 678 1120">Pull it upwards to separate the chassis and condenser.</p> 

VIRU36HP230V1AO VIRU30HP230V1AO

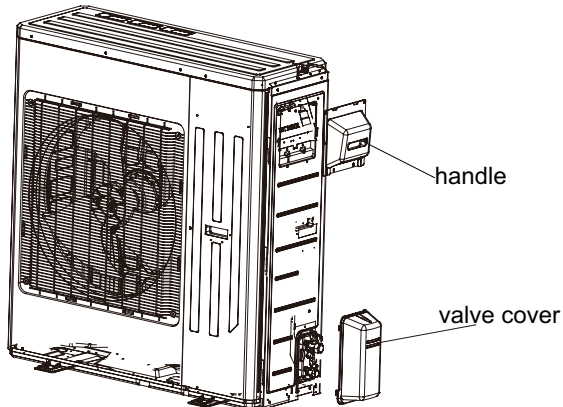
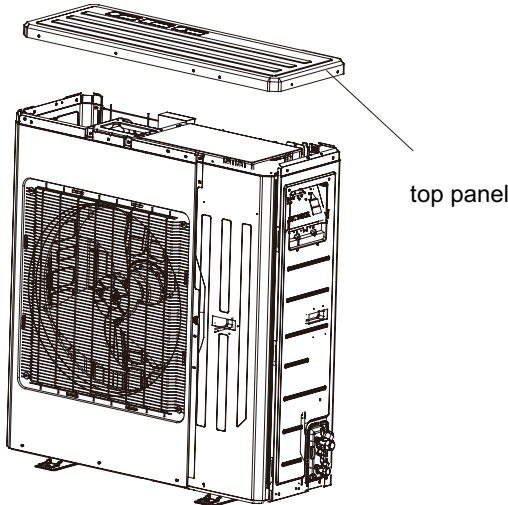
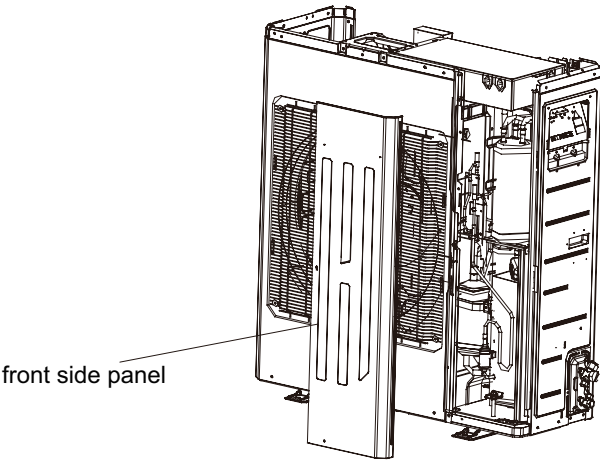
Steps	Procedure
<p>1. Remove big handle, valve cover and top cover</p>	<p>Remove the screw connecting the big handle and right side plate, and then remove the big handle. Remove the screw connecting the valve cover and right side plate, and then remove the valve cover.</p>  <p>Labels: handle, valve cover</p>
<p>2. Remove top panel</p>	<p>Remove the screws connecting the top panel with the front panel and left & right side plate, and then remove the top panel.</p>  <p>Label: top panel</p>
<p>3. Remove front side panel</p>	<p>Loosen the screws connecting the front side panel and chassis. Remove the front side panel.</p>  <p>Label: front side panel</p>

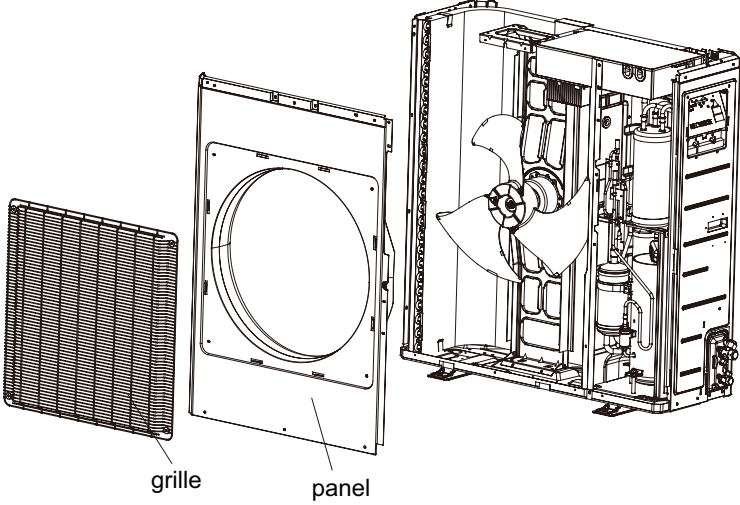
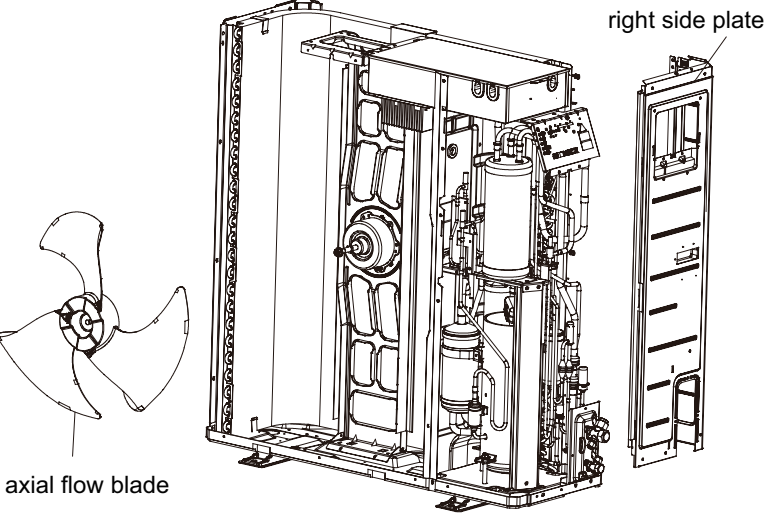
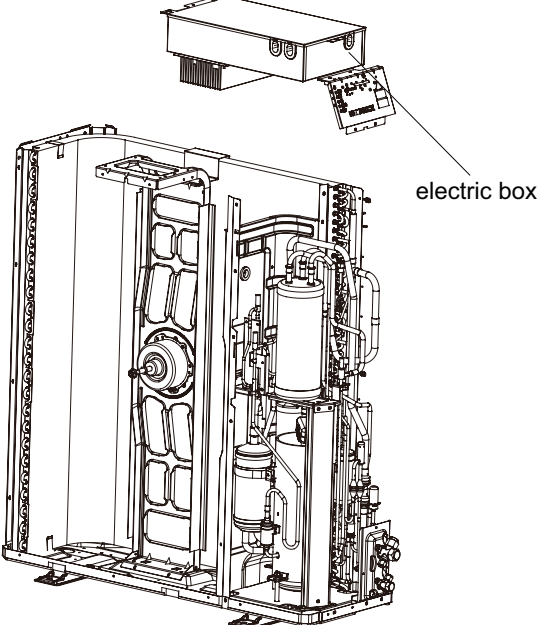
Steps	Procedure
<p>4.Remove grille and panel</p>	<p>Twist off the screws connecting the grille and panel, and then remove the grille.</p> <p>Twist off the screws connecting the panel, chassis and motor support with screw-driver, and then remove the panel.</p>  <p>grille panel</p>
<p>5.Remove right side plate and axial flow blade</p>	<p>Twist off the screws connecting the right side plate and chassis, valve support and condenser, and then remove the right side plate.</p> <p>Twist off the nuts on blade with wrench and then remove the axial flow blade.</p>  <p>axial flow blade right side plate</p>
<p>6.Remove electric box</p>	<p>Twist off the screws on electric box, cut off the tieline with scissors or pliers, pull out the wiring terminal, pull it upwards to remove the electric box.</p>  <p>electric box</p>

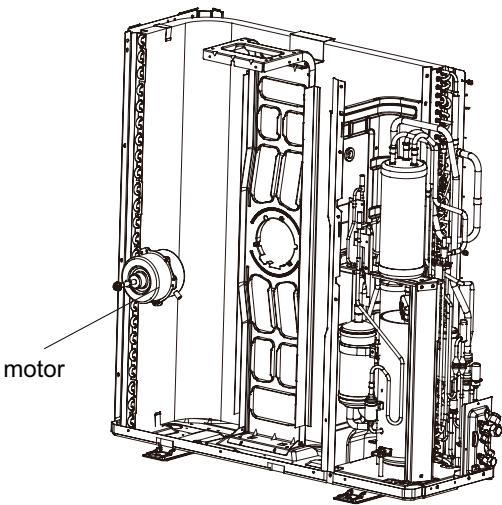
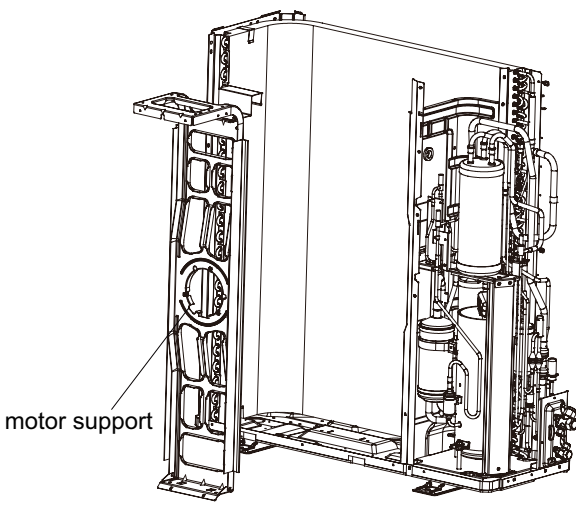
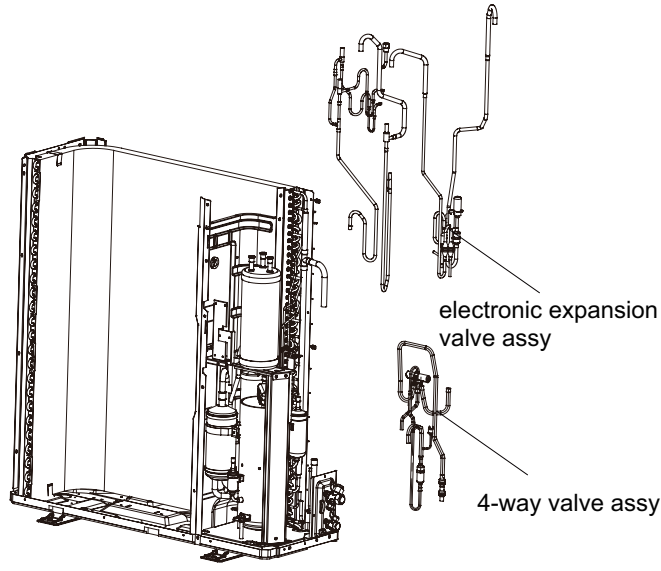
Steps	Procedure
8.Remove motor	<p>Twist off the tapping screws fixing the motor, pull out the pin of leading wire for motor and then remove the motor.</p> 
9.Remove motor support	<p>Twist off the tapping screws fixing the motor support, pull it upwards and then remove the motor support.</p> 
10.Remove 4-way valve assy and electronic expansion valve assy	<p>Unsolder the spot weld of 4-way valve assy, electronic expansion, compressor and condenser, and then remove the 4-way valve assy and electronic expansion sub-assy.</p> <p>Note: When unsoldering the spot weld, wrap the 4-way valve with wet cloth completely to avoid damaging the valve due to high temperature.</p> 

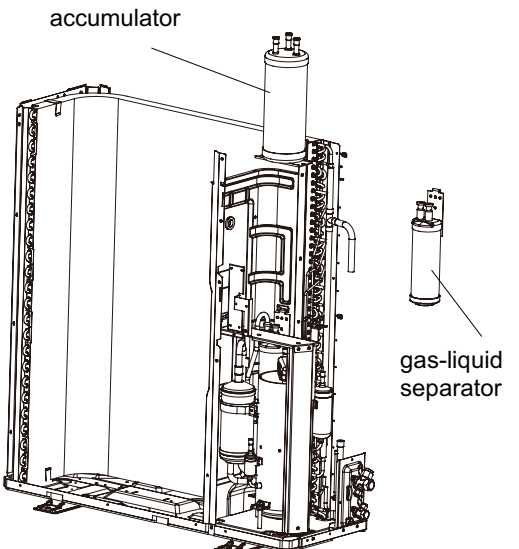
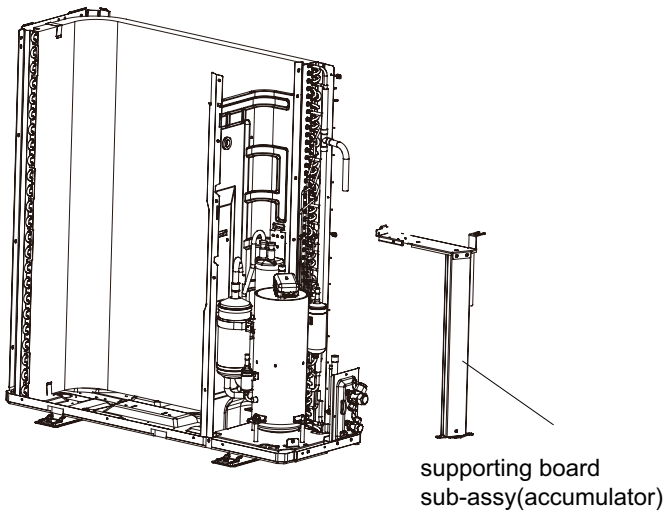
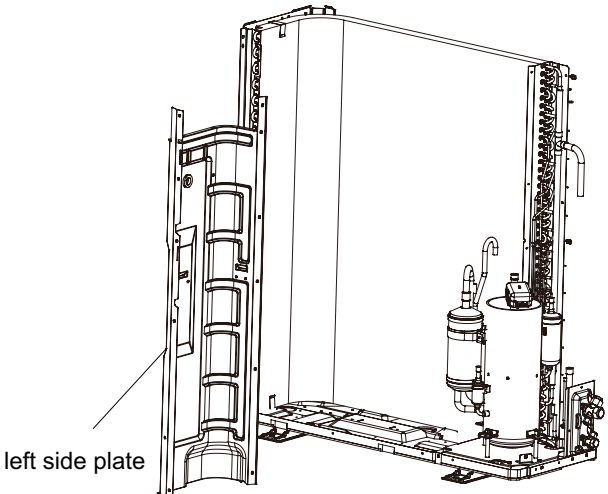
Steps	Procedure
<p>11.Remove accumulator and gas-liquid separator</p>	<p>Twist off the screws connecting accumulator and gas-liquid separator, and then remove the accumulator and gas-liquid separator.</p>  <p>accumulator</p> <p>gas-liquid separator</p>
<p>12.Remove supporting board sub-assy(accumulator)</p>	<p>Twist off the screws connecting supporting board sub-assy(accumulator) and then remove the supporting board sub-assy(accumulator).</p>  <p>supporting board sub-assy(accumulator)</p>
<p>13.Remove left side plate</p>	<p>Twist off the screws connecting the left side plate and chassis with screwdriver, and then remove the left side plate.</p>  <p>left side plate</p>

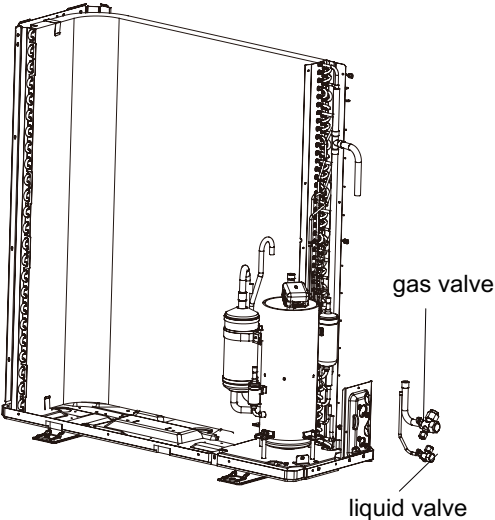
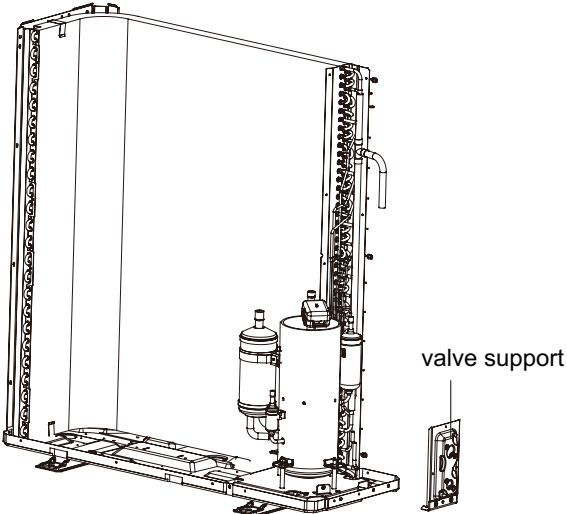
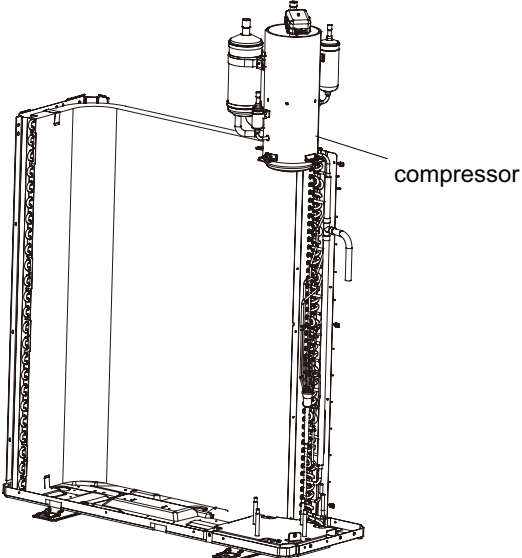
Steps	Procedure
14.Remove gas valve and liquid valve	<p>Twist off the 2 bolts fixing the valve sub-assy. Unsolder the soldering joint between gas valve and air-return pipe and then remove the gas valve.(note: when unsoldering the soldering joint, wrap the gas valve with wet cloth completely to avoid the damage to valve, and release all refrigerant completely at first). Unsolder the soldering joint between liquid valve and connection pipe of liquid valve, and then remove the liquid valve.</p>  <p style="text-align: right;">gas valve liquid valve</p>
15.Remove valve support	<p>Twist off the screws connecting valve support and chassis, and then remove the valve support.</p>  <p style="text-align: right;">valve support</p>
16.Remove compressor	<p>Twist off the 3 foot nuts on compressor and then remove the compressor.</p>  <p style="text-align: right;">compressor</p>

Appendix:

Appendix 1: Reference Sheet of Celsius and Fahrenheit

Conversion formula for Fahrenheit degree and Celsius degree: $T_f = T_c \times 1.8 + 32$

Set temperature

Fahrenheit display temperature (°F)	Fahrenheit (°F)	Celsius (°C)	Fahrenheit display temperature (°F)	Fahrenheit (°F)	Celsius (°C)	Fahrenheit display temperature (°F)	Fahrenheit (°F)	Celsius (°C)
61	60.8	16	69/70	69.8	21	78/79	78.8	26
62/63	62.6	17	71/72	71.6	22	80/81	80.6	27
64/65	64.4	18	73/74	73.4	23	82/83	82.4	28
66/67	66.2	19	75/76	75.2	24	84/85	84.2	29
68	68	20	77	77	25	86	86	30

Ambient temperature

Fahrenheit display temperature (°F)	Fahrenheit (°F)	Celsius (°C)	Fahrenheit display temperature (°F)	Fahrenheit (°F)	Celsius (°C)	Fahrenheit display temperature (°F)	Fahrenheit (°F)	Celsius (°C)
32/33	32	0	55/56	55.4	13	79/80	78.8	26
34/35	33.8	1	57/58	57.2	14	81	80.6	27
36	35.6	2	59/60	59	15	82/83	82.4	28
37/38	37.4	3	61/62	60.8	16	84/85	84.2	29
39/40	39.2	4	63	62.6	17	86/87	86	30
41/42	41	5	64/65	64.4	18	88/89	87.8	31
43/44	42.8	6	66/67	66.2	19	90	89.6	32
45	44.6	7	68/69	68	20	91/92	91.4	33
46/47	46.4	8	70/71	69.8	21	93/94	93.2	34
48/49	48.2	9	72	71.6	22	95/96	95	35
50/51	50	10	73/74	73.4	23	97/98	96.8	36
52/53	51.8	11	75/76	75.2	24	99	98.6	37
54	53.6	12	77/78	77	25			

Appendix 2: Configuration of Connection Pipe

- Standard length of connection pipe (More details please refer to the specifications.)
- Min. length of connection pipe is 9.84ft.
- Max. length of connection pipe and max. high difference.(More details please refer to the specifications.)
- The additional refrigerant oil and refrigerant charging required after prolonging connection pipe
 - After the length of connection pipe is prolonged for 32.81ft at the basis of standard length, you should add 5ml of refrigerant oil for each additional 16.40ft of connection pipe.
 - The calculation method of additional refrigerant charging amount (on the basis of liquid pipe):
 - When the length of connection pipe is above 16.40ft, add refrigerant according to the prolonged length of liquid pipe. The additional refrigerant charging amount per meter is different according to the diameter of liquid pipe. See the following sheet.
 - Additional refrigerant charging amount = prolonged length of liquid pipe X additional refrigerant charging amount per meter

Additional refrigerant charging amount for R22, R407C, R410A and R134a			
Diameter of connection pipe		Outdoor unit throttle	
Liquid pipe(inch)	Gas pipe(inch)	Cooling only(oz/ft.)	Cooling and heating(oz/ft.)
Φ1/4	Φ3/8or Φ1/2	0.2	0.2
Φ1/4 or Φ3/8	Φ5/8 or Φ3/4	0.2	0.2
Φ1/2	Φ3/4 or Φ7/8	0.3	1.3
Φ5/8	Φ1 or Φ1 1/4	0.7	1.3
Φ3/4	/	2.7	2.7
Φ7/8	/	3.8	3.8

Appendix 3: Pipe Expanding Method

⚠ Note:

Improper pipe expanding is the main cause of refrigerant leakage. Please expand the pipe according to the following steps:

A: Cut the pip

- Confirm the pipe length according to the distance of indoor unit and outdoor unit.
- Cut the required pipe with pipe cutter.

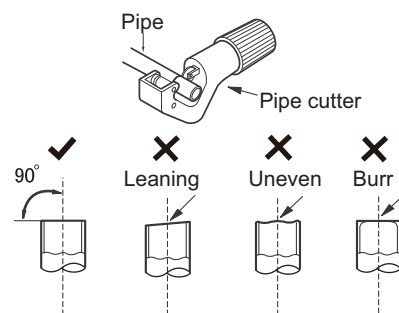

B: Remove the burrs

- Remove the burrs with shaper and prevent the burrs from getting into the pipe.

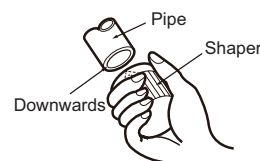

C: Put on suitable insulating pipe

D: Put on the union nut

- Remove the union nut on the indoor connection pipe and outdoor valve; install the union nut on the pipe.

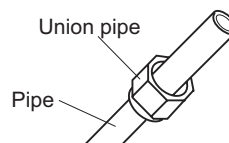

E: Expand the port

- Expand the port with expander.

⚠ Note:

- "A" is different according to the diameter, please refer to the sheet below:

Outer diameter(inch)	A(inch)	
	Max	Min
Φ1/4	2/39	1/36
Φ3/8	1/16	1/51
Φ1/2	1/14	1/51
Φ5/8	5/53	2/23

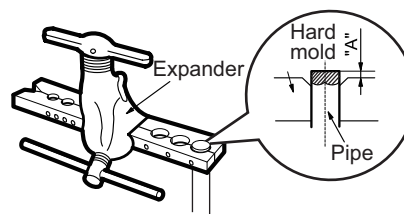

F: Inspection

- Check the quality of expanding port. If there is any blemish, expand the port again according to the steps above.

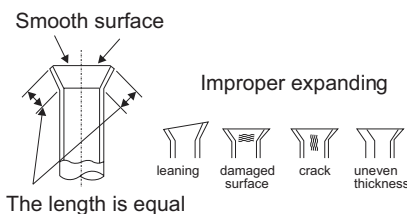

Appendix 4: List of Resistance for Temperature Sensor

Resistance Table of Ambient Temperature Sensor for Indoor and Outdoor Units(15K)

Temp.(°F)	Resistance(kΩ)	Temp.(°F)	Resistance(kΩ)	Temp.(°F)	Resistance(kΩ)	Temp.(°F)	Resistance(kΩ)
-2.2	138.1	68	18.75	138.2	3.848	208.4	1.071
-0.4	128.6	69.8	17.93	140	3.711	210.2	1.039
1.4	121.6	71.6	17.14	141.8	3.579	212	1.009
3.2	115	73.4	16.39	143.6	3.454	213.8	0.98
5	108.7	75.2	15.68	145.4	3.333	215.6	0.952
6.8	102.9	77	15	147.2	3.217	217.4	0.925
8.6	97.4	78.8	14.36	149	3.105	219.2	0.898
10.4	92.22	80.6	13.74	150.8	2.998	221	0.873
12.2	87.35	82.4	13.16	152.6	2.896	222.8	0.848
14	82.75	84.2	12.6	154.4	2.797	224.6	0.825
15.8	78.43	86	12.07	156.2	2.702	226.4	0.802
17.6	74.35	87.8	11.57	158	2.611	228.2	0.779
19.4	70.5	89.6	11.09	159.8	2.523	230	0.758
21.2	66.88	91.4	10.63	161.6	2.439	231.8	0.737
23	63.46	93.2	10.2	163.4	2.358	233.6	0.717
24.8	60.23	95	9.779	165.2	2.28	235.4	0.697
26.6	57.18	96.8	9.382	167	2.206	237.2	0.678
28.4	54.31	98.6	9.003	168.8	2.133	239	0.66
30.2	51.59	100.4	8.642	170.6	2.064	240.8	0.642
32	49.02	102.2	8.297	172.4	1.997	242.6	0.625
33.8	46.6	104	7.967	174.2	1.933	244.4	0.608
35.6	44.31	105.8	7.653	176	1.871	246.2	0.592
37.4	42.14	107.6	7.352	177.8	1.811	248	0.577
39.2	40.09	109.4	7.065	179.6	1.754	249.8	0.561
41	38.15	111.2	6.791	181.4	1.699	251.6	0.547
42.8	36.32	113	6.529	183.2	1.645	253.4	0.532
44.6	34.58	114.8	6.278	185	1.594	255.2	0.519
46.4	32.94	116.6	6.038	186.8	1.544	257	0.505
48.2	31.38	118.4	5.809	188.6	1.497	258.8	0.492
50	29.9	120.2	5.589	190.4	1.451	260.6	0.48
51.8	28.51	122	5.379	192.2	1.408	262.4	0.467
53.6	27.18	123.8	5.197	194	1.363	264.2	0.456
55.4	25.92	125.6	4.986	195.8	1.322	266	0.444
57.2	24.73	127.4	4.802	197.6	1.282	267.8	0.433
59	23.6	129.2	4.625	199.4	1.244	269.6	0.422
60.8	22.53	131	4.456	201.2	1.207	271.4	0.412
62.6	21.51	132.8	4.294	203	1.171	273.2	0.401
64.4	20.54	134.6	4.139	204.8	1.136	275	0.391
66.2	19.63	136.4	3.99	206.6	1.103	276.8	0.382

Resistance Table of Tube Temperature Sensors for Indoor and Outdoor (20K)

Temp.(°F)	Resistance(kΩ)	Temp.(°F)	Resistance(kΩ)	Temp.(°F)	Resistance(kΩ)	Temp.(°F)	Resistance(kΩ)
-2.2	181.4	68	25.01	138.2	5.13	208.4	1.427
-0.4	171.4	69.8	23.9	140	4.948	210.2	1.386
1.4	162.1	71.6	22.85	141.8	4.773	212	1.346
3.2	153.3	73.4	21.85	143.6	4.605	213.8	1.307
5	145	75.2	20.9	145.4	4.443	215.6	1.269
6.8	137.2	77	20	147.2	4.289	217.4	1.233
8.6	129.9	78.8	19.14	149	4.14	219.2	1.198
10.4	123	80.6	18.13	150.8	3.998	221	1.164
12.2	116.5	82.4	17.55	152.6	3.861	222.8	1.131
14	110.3	84.2	16.8	154.4	3.729	224.6	1.099
15.8	104.6	86	16.1	156.2	3.603	226.4	1.069
17.6	99.13	87.8	15.43	158	3.481	228.2	1.039
19.4	94	89.6	14.79	159.8	3.364	230	1.01
21.2	89.17	91.4	14.18	161.6	3.252	231.8	0.983
23	84.61	93.2	13.59	163.4	3.144	233.6	0.956
24.8	80.31	95	13.04	165.2	3.04	235.4	0.93
26.6	76.24	96.8	12.51	167	2.94	237.2	0.904
28.4	72.41	98.6	12	168.8	2.844	239	0.88
30.2	68.79	100.4	11.52	170.6	2.752	240.8	0.856
32	65.37	102.2	11.06	172.4	2.663	242.6	0.833
33.8	62.13	104	10.62	174.2	2.577	244.4	0.811
35.6	59.08	105.8	10.2	176	2.495	246.2	0.777
37.4	56.19	107.6	9.803	177.8	2.415	248	0.769
39.2	53.46	109.4	9.42	179.6	2.339	249.8	0.746
41	50.87	111.2	9.054	181.4	2.265	251.6	0.729
42.8	48.42	113	8.705	183.2	2.194	253.4	0.71
44.6	46.11	114.8	8.37	185	2.125	255.2	0.692
46.4	43.92	116.6	8.051	186.8	2.059	257	0.674
48.2	41.84	118.4	7.745	188.6	1.996	258.8	0.658
50	39.87	120.2	7.453	190.4	1.934	260.6	0.64
51.8	38.01	122	7.173	192.2	1.875	262.4	0.623
53.6	36.24	123.8	6.905	194	1.818	264.2	0.607
55.4	34.57	125.6	6.648	195.8	1.736	266	0.592
57.2	32.98	127.4	6.403	197.6	1.71	267.8	0.577
59	31.47	129.2	6.167	199.4	1.658	269.6	0.563
60.8	30.04	131	5.942	201.2	1.609	271.4	0.549
62.6	28.68	132.8	5.726	203	1.561	273.2	0.535
64.4	27.39	134.6	5.519	204.8	1.515	275	0.521
66.2	26.17	136.4	5.32	206.6	1.47	276.8	0.509

Resistance Table of Discharge Temperature Sensor for Outdoor(50K)

Temp.(°F)	Resistance(kΩ)	Temp.(°F)	Resistance(kΩ)	Temp.(°F)	Resistance(kΩ)	Temp.(°F)	Resistance(kΩ)
-20.2	853.5	50	98	120.2	18.34	190.4	4.754
-18.4	799.8	51.8	93.42	122	17.65	192.2	4.609
-16.6	750	53.6	89.07	123.8	16.99	194	4.469
-14.8	703.8	55.4	84.95	125.6	16.36	195.8	4.334
-13	660.8	57.2	81.05	127.4	15.75	197.6	4.204
-11.2	620.8	59	77.35	129.2	15.17	199.4	4.079
-9.4	580.6	60.8	73.83	131	14.62	201.2	3.958
-7.6	548.9	62.6	70.5	132.8	14.09	203	3.841
-5.8	516.6	64.4	67.34	134.6	13.58	204.8	3.728
-4	486.5	66.2	64.33	136.4	13.09	206.6	3.619
-2.2	458.3	68	61.48	138.2	12.62	208.4	3.514
-0.4	432	69.8	58.77	140	12.17	210.2	3.413
1.4	407.4	71.6	56.19	141.8	11.74	212	3.315
3.2	384.5	73.4	53.74	143.6	11.32	213.8	3.22
5	362.9	75.2	51.41	145.4	10.93	215.6	3.129
6.8	342.8	77	49.19	147.2	10.54	217.4	3.04
8.6	323.9	78.8	47.08	149	10.18	219.2	2.955
10.4	306.2	80.6	45.07	150.8	9.827	221	2.872
12.2	289.6	82.4	43.16	152.6	9.489	222.8	2.792
14	274	84.2	41.34	154.4	9.165	224.6	2.715
15.8	259.3	86	39.61	156.2	8.854	226.4	2.64
17.6	245.6	87.8	37.96	158	8.555	228.2	2.568
19.4	232.6	89.6	36.38	159.8	8.268	230	2.498
21.2	220.5	91.4	34.88	161.6	7.991	231.8	2.431
23	209	93.2	33.45	163.4	7.726	233.6	2.365
24.8	198.3	95	32.09	165.2	7.47	235.4	2.302
26.6	199.1	96.8	30.79	167	7.224	237.2	2.241
28.4	178.5	98.6	29.54	168.8	6.998	239	2.182
30.2	169.5	100.4	28.36	170.6	6.761	240.8	2.124
32	161	102.2	27.23	172.4	6.542	242.6	2.069
33.8	153	104	26.15	174.2	6.331	244.4	2.015
35.6	145.4	105.8	25.11	176	6.129	246.2	1.963
37.4	138.3	107.6	24.13	177.8	5.933	248	1.912
39.2	131.5	109.4	23.19	179.6	5.746	249.8	1.863
41	125.1	111.2	22.29	181.4	5.565	251.6	1.816
42.8	119.1	113	21.43	183.2	5.39	253.4	1.77
44.6	113.4	114.8	20.6	185	5.222	255.2	1.725
46.4	108	116.6	19.81	186.8	5.06	257	1.682
48.2	102.8	118.4	19.06	188.6	4.904	258.8	1.64



JF00302748

GREE_VIR B & C_VIRU_LIVS B & C_LIVV_30 & 36 SERVICE_01252021



GREE ELECTRIC APPLIANCES, INC. OF ZHUHAI

Add: West Jinji Rd, Qianshan, Zhuhai, Guangdong, China, 519070

Tel: (+86-756) 8522219

Fax: (+86-756) 8669426

E-mail: global@cn.gree.com www.gree.com

For product improvement, specifications and appearance in this manual are subject to change without prior notice.