



Submittal Data: UMAT48HP230V1AC 48,000 BTUH Ceiling Cassette Heat Pump System

Job Name Location Date

Purchaser Engineer

Submitted To For Reference Approval Construction

Unit Designation Schedule No.

GENERAL FEATURES

- Multi-Speed Fan
- 4-way Discharge Air
- Internal Condensate Drain Pump
- Wireless Remote Controllers
- Power Failure Recovery
- Sentry Condensate Overflow Protection
- Decorative Grille (Part# UMAT48GRILLE -Sold Separately)
- 5 yr. Limited Parts & Compressor Warranty (Residential Only)



System Ratings

Cooling		
Rated Capacity		48,000 BTU/H
Capacity Range		20,400-50,500 BTU/H
Power Input (Max)		5,700 W
SEER		16.0
EER		8.7
Heating at 47° F		
Rated Capacity		54,500 BTU/H
Capacity Range		17,500-61,500 BTU/H
Power Input (Max)		5,400 W
HSPF		9.0
COP		3.3
Heating at 17° F		
Rated Capacity		27,600 BTU/H
Operating Range		
Cooling	(Max)	118°F (48°C)
	(Min)	0°F (-18°C)
Heating	(Max)	75°F (24°C)
	(Min)	0°F (-18°C)
Refrigerant Piping Data		
Gas Pipe Size (OD)		5/8-in
Liquid Pipe Size (OD)		3/8-in
Connection Method		Flared
Factory Charge		140.8 oz
Additional Charge		0.6 oz/ft
Pre-Charge Length		25-ft
MAX Refrigerant Pipe Length		230-ft
MIN Refrigerant Pipe Length		10-ft
MAX Refrigerant Pipe Elevation		49-ft

Indoor Unit Data

Fan Motor	Output Power	1/7HP
	FLA	1.5 A
Airflow		
	Cooling Wet (Lo/Hi)	900/1350 CFM
	Heating Dry (Lo/Hi)	900/1350 CFM
Air Throw (max)		19.7 ft
Sound Level		
	Cooling (Min/Max)	41/53 dB(A)
	Heating (Min/Max)	41/53 dB(A)
Dehumidication		2.13 pt/hr
Condensate Drain Lift (Height)		33 in
Power Supply (Dedicated Circuit: Size Per Local Code)		
	Normal Operational Voltage	208/230 V, 1 Phase, 60 Hz
	Voltage Range	187 - 253 V
	MCA	2.0 A
	MOCP/Breaker Size	15 A
Communication Wire Size		18-2 AWG / 300V THHN

Outdoor Unit Data

Compressor		DC Inverter Driven Rotary
	RLA	35.5 A
Refrigerant Type		R410A
Fan Motor	Output Power	2 x 1/6HP
	FLA	2 x 2.0 A
Sound Level		
	Cooling/Heating	59/59 dB(A)
Power Supply (Dedicated Circuit)		
	Normal Operational Voltage	208/230 V, 1 Phase, 60 Hz
	Voltage Range	187 - 253 V
	Main Supply Wire Size	8 AWG
	MCA	36.5 A
	MOCP/Breaker Size	60 A



SYSTEM FEATURES	
Inverter Type	G10
Ultra Low Frequency Torque Control	Yes
Power Factor Correction	Yes
Compressor Type	Rotary
Refrigerant Type	R410A
Basepan With Electric Heater	YES
Compressor With Electric Heater	YES
Outdoor Fin Coating	Acrylic Resin
Intelligent Defrosting	YES
Intelligent Preheating	YES
Low Voltage Startup	YES
Memory/Power Failure Recovery	YES
Self Diagnosis	YES
Low Ambient Cooling	YES
Internal Condensate Pump	YES
XK60 (Opt) Wired Controller Interface	YES
Wi-Fi Interface	NO
Indoor Fan Type	Centrifugal
Multi Fan Speeds	3 Speeds
LED Display Indoor Unit	YES
Advance Filter	NO
Auxiliary Electrical Heater	NO
Ventilation (Outdoor Air)	Optional

REMOTE CONTROLLER FUNCTIONS	
Auto Mode	YES
Auto Fan	YES
Auto Swing (Continuous Sweep)	YES
Adjustable Swing Louvers (5 pos.)	YES
Clock on Remote Controller	YES
Dry Mode	YES
Dry Anti-Mildew (X-Fan) Mode	YES
Energy Saving Mode	NO
Dirty Filter Alert	NO
I Feel Function	YES
Lock on Remote Controller	YES
Quiet Mode	NO
Room Temperature Display (5 sec.)	YES
Sleep Mode	YES
4 Sleep Modes Options	YES
Timer Mode	YES
Turbo Mode	YES
Display On/Off Control	YES
Freeze Guard Mode	NO

EXTENDED RATINGS

COOLING PERFORMANCE

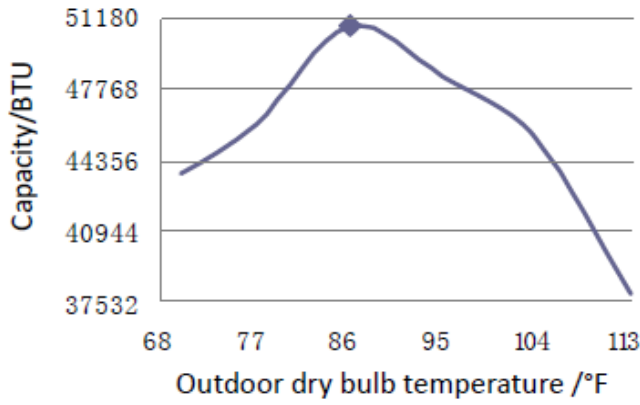

HEATING PERFORMANCE

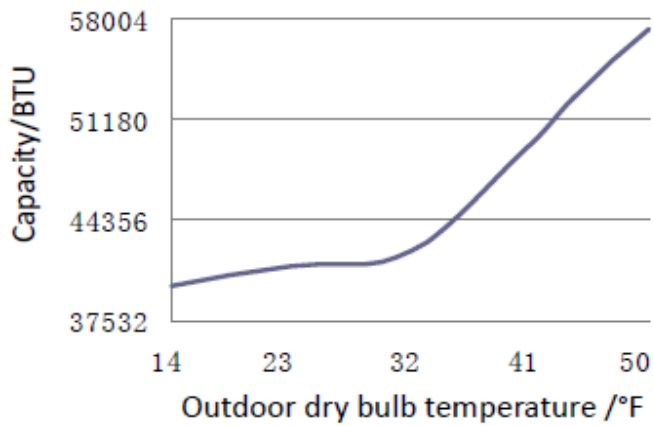

MINIMUM SPACING REQUIREMENTS

Units: inch (mm)

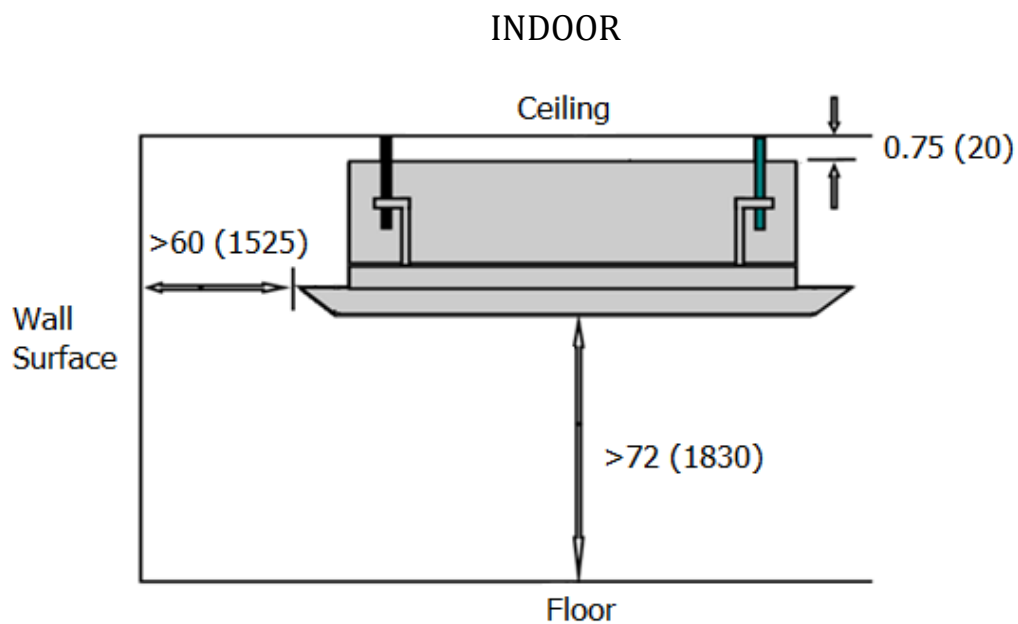

Units: inch (mm)

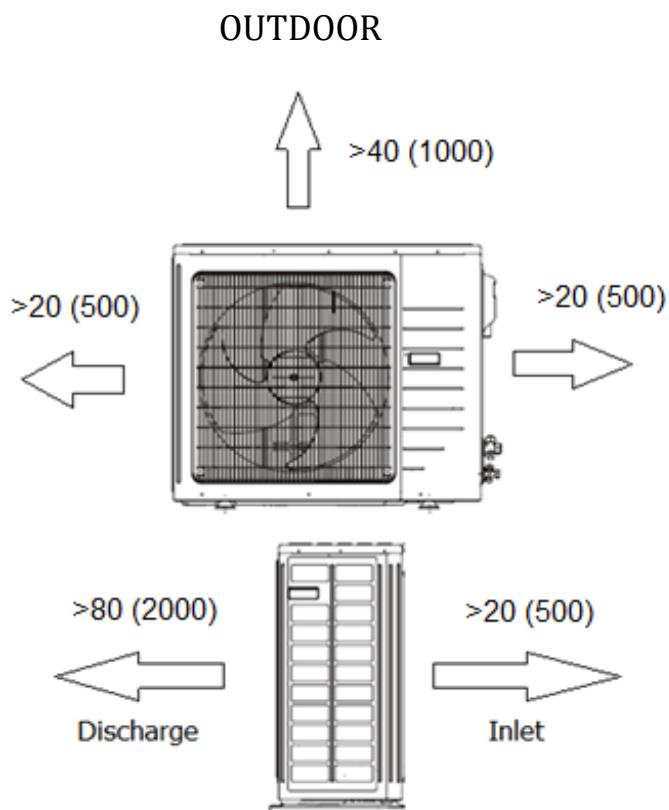

DIMENSIONAL SPECIFICATIONS

UMAT48HP230V1AC

INDOOR UNIT DIMENSIONS & WEIGHTS

Units: inch (mm)

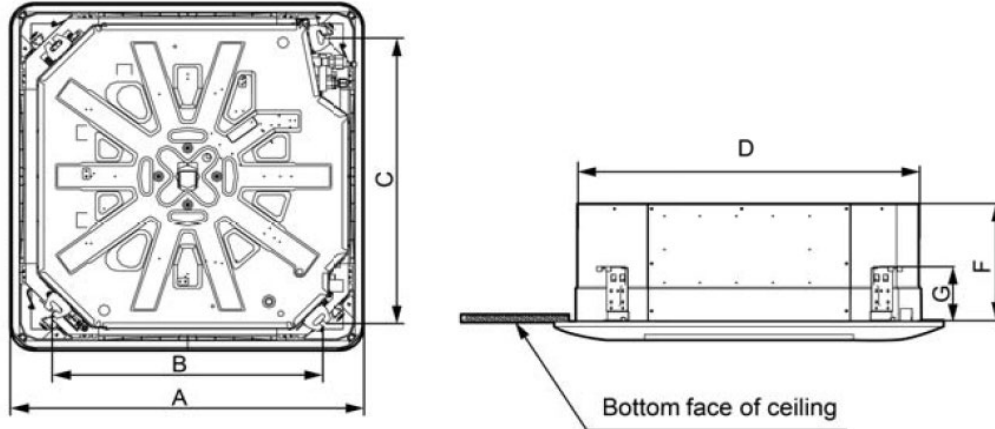

	A	B	C	D	F	G
in	41.0	31-1/8	33-1/8	35-7/8	11-3/8	(140)
mm	(1040)	(790)	(842)	(910)	(290)	290

Liquid Line Valve	3/8-in OD Flared
Gas Line Valve	5/8-in OD Flared
Drain Connector	1-in OD

Net Weight	94.6 lbs
Shipping Weight	110.0 lbs

OUTDOOR UNIT DIMENSIONS & WEIGHTS

Units: inch (mm)

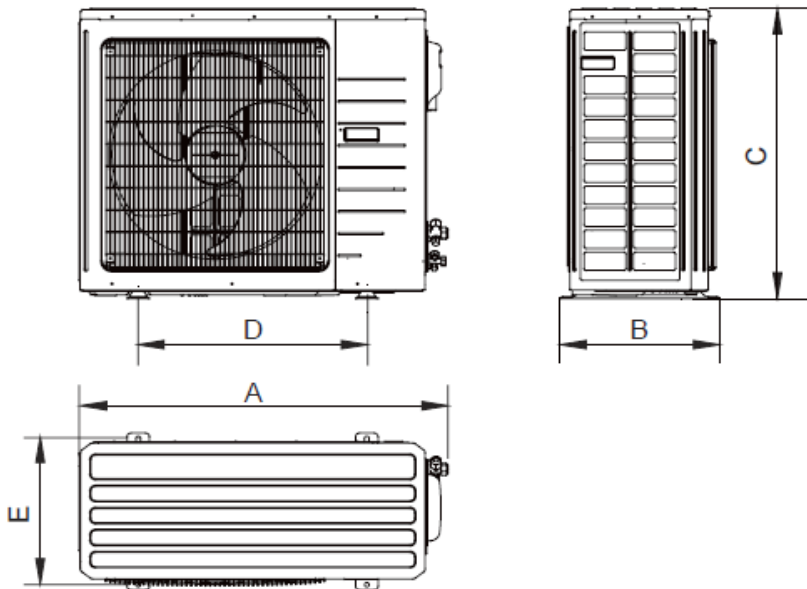

A	37-3/4 (960)
B	16-1/4 (410)
C	53-1/8 (1350)
D	22-1/2 (570)
E	14-3/4 (375)

Net Weight	231.0 lbs
Shipping Weight	253.0 lbs

Liquid Line Valve	3/8-in OD Flared
Gas Line Valve	5/8-in OD Flared

Notes:

1. Recommended Communication WireType 18-2 AWG Stranded Copper THHN 300V Wire
2. Power wiring size must comply with applicable national and local codes for both ID and OD dedicated circuits.
3. Test conditions are based on AHRI 210/240.

Specifications are subject to change without notice. Manufacturer reserves the right to discontinue or modify specifications or designs without notice or without incurring obligations. All rights reserved.