



**Ultra Heat GMV Multi VRF for
North America**

R410A(GC201603-1)

CONTENTS

PRODUCT	2
1 PRODUCT LIST	2
2 NOMENCLATURE	3
3 PRODUCT FEATURES.....	4
4 SPECIFICATIONS.....	5
5 CAPACITY CODE	10
6 PRINCIPAL OF OPERATION.....	11
CONTROL.....	13
1 Units' Control.....	14
2 Wired Controller	15
3 Remote Controller	34
INSTALLATION.....	36
1 Engineering Installation Preparation and Notice	37
2 Installation Materials Selection.....	37
3 Installation of outdoor unit	39
4 Installation of indoor Unit	40
5 Installation of Electronic Expansion Valve Assy (unit with external EXV).....	43
6 Installation of Refrigerant Pipeline	44
7 Installation of the Connection Pipe.....	47
8 Installation of Condensate Pipes.....	52
9 Electric Wiring	54
10 Debugging of Unit	58
MAINTENANCE.....	66
1 Malfunction List	67
2 Troubleshooting	69
3 Power Distribution of Unit.....	73
4 Removal of Parts.....	76
5 Vacuum drying for the system.	89
6 Exploded View of Unit and Parts' List	92

PRODUCT



PRODUCT

1 PRODUCT LIST

1.1 Outdoor Unit

Model	Product Code	Cooling Capacity	Heating Capacity	Power Supply	Refrigerant	Appearance
		Kw(Btu/h)	Kw(Btu/h)			
GMV-36WL/B-T(U)	CN850W0380	10.5 (36000)	13.2 (45000)	208/230V ~ 60Hz	R410A	
GMV-48WL/B-T(U)	CN850W0360	14.1 (48000)	15.8 (54000)			

1.2 Indoor Unit

1.2.1 Low static pressure duct

Model	Product Code	Cooling Capacity	Heating Capacity	Power Supply	Refrigerant	Appearance
		kW(Btu/h)	kW(Btu/h)			
GMV-ND07PLS/ A-T(U)	CM810N0080	2.2 (7500)	2.5 (8500)	208/230V ~ 60Hz	R410a	
GMV-ND09PLS/ A-T(U)	CM810N0090	2.8 (9500)	3.1 (10500)			
GMV-ND12PLS/ A-T(U)	CM810N0100	3.5 (12000)	4.0 (13500)			
GMV-ND14PLS/ A-T(U)	CM810N0120	4.0 (13800)	4.5 (15500)			
GMV-ND18PLS/ A-T(U)	CM810N0070	5.2 (18000)	5.2 (20000)			
GMV-ND22PLS/ A-T(U)	CM810N0110	6.3 (22000)	7.1 (24000)			

1.2.2 Four-way Cassette

Model	Product Code	Cooling Capacity	Heating Capacity	Power Supply	Refrigerant	Appearance
		kW (Btu/h)	kW (Btu/h)			
GMV-ND07T/ A-T(U)	CM500N0520	2.2 (7500)	2.5 (8500)	208/230V ~ 60Hz	R410a	
GMV-ND09T/ A-T(U)	CM500N0530	2.8 (9500)	3.1 (10500)			
GMV-ND12T/ A-T(U)	CM500N0540	3.5 (12000)	4.0 (13500)			
GMV-ND15T/ A-T(U)	CM810N0130	4.4 (15000)	5 (17000)			
GMV-ND18T/ A-T(U)	CM500N0510	5.3 (18000)	5.9 (20000)			
GMV-ND24T/ A-T(U)	CM500N0550	7.0 (24000)	7.9 (27000)			
GMV-ND30T/ A-T(U)	CM500N0560	8.8 (30000)	10 (34000)			
GMV-ND36T/ A-T(U)	CM500N0570	10.6 (36000)	11.7 (40000)			
GMV-ND42T/ A-T(U)	CM500N0580	12.3 (42000)	13.8 (47000)			
GMV-ND48T/ A-T(U)	CM500N0590	14.1 (48000)	15.8 (54000)			

1.2.3 Wall Mounted Type IDU

Model	Product Code	Cooling Capacity	Heating Capacity	Power Supply	Power Supply	Appearance
		kW (Btu/h)	kW (Btu/h)			
GMV-N07G/A3A-D(U)	CM100N1480	2.2 (7500)	2.5 (8500)	208/230V ~ 60Hz	R410a	
GMV-N09G/A3A-D(U)	CM100N1490	2.8 (9500)	3.2 (11000)			
GMV-N12G/A3A-D(U)	CM100N1500	3.5 (12000)	4.0 (13500)			
GMV-N18G/A3A-D(U)	CM100N1510	5.2 (18000)	5.8 (20000)			
GMV-N24G/A3A-D(U)	CM100N1520	7.0 (24000)	7.5 (25500)			

2 NOMENCLATURE

2.1 Nomenclature of outdoor units

GMV	□	-	□	□	□	□	W	□	/	□	□	□
1	2		3	4	5	6	7		8	9	10	

No.	Description	Options
1	Product code	GMV-Gree Multi VRF Units
2	Suitable climate	Blank-T1 condition; T2-low temperature climate; T3-high temperature climate
3	Unit type	DC Inverter (omit)
4	Function code	Q—Heat Recovery; S—Water Heater; W—Water-cooled Unit; X—Fresh Air Unit Leave blank if above functions are unavailable.
5	Code of cooling capacity	Nominal capacity/100(W)
6	Unit structure	M—Modular (top discharge); L—Non-modular (side discharge); blank—Non-modular (top discharge)
7	Refrigerant	R410a (omit)
8	Design No.	Named in order of A, B, C, or combined with 1, 2, 3...
9	Power supply	7000~18000W, 1 phase—omit; 3 phase—S

2.2 Nomenclature of indoor units

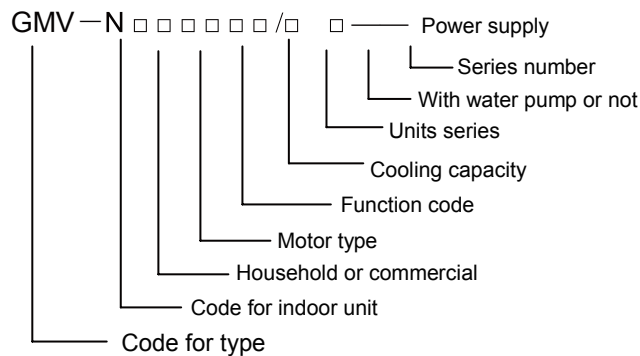

Code for multi VRF	—	Code for indoor unit	Motor type	Function code	Cooling capacity
GMV	—	N	D-DC motor Default-AC motor	R-heat pump L-cooling only X-fresh air W-dual heat sources Q-heat recovery Default-electric heating	Nominal cooling capacity/100(W)
Classification			With water pump or not	Series number	Power supply
PL-Low static pressure duct type indoor unit; P-Standard static pressure duct type indoor; PH-High static pressure duct type indoor unit; PB-Thin duct type indoor unit; T-Four-way cassette; TD-Single-way cassette; TS-Two-way cassette; C-Floor mounting unit; ZD-Floor ceiling unit; G-Wall-mounted unit			With water pump-S (All cassette indoor units are with water pump, S is not presented in the model same)	A, B, C... or 1, 2, 3...	Select power supply code according to power supply specification

3 PRODUCT FEATURES

3.1 General introduction

Gree Multi VRF System adopts inverter compressor technology. By changing the displacement of compressor, stepless capacity regulation within range of 15%~100% can be realized. Various product lineups are provided with capacity range from 36000Btu/h to 48000Btu/h, which can be widely used in residential, commercial and working area and especially applicable to places with big load change. It features Superior heating performance, high capacity and energy efficiency.

3.1.1 Features

- (1) Superior heating performance.
Continuous heating down to -20°C, without weakening, which is the highest level in the trade.
- (2) High capacity and energy efficiency
When heating at low temperature and cooling at high temperature, its capacity has increased by 60% and COP has increased by 20% compared to the traditional systems.
- (3) No-brige PFC control technology
Compared to traditional one, no-brige PFC control technology has many advantages like less energy wasting, low electromagnetism disturbing and so on.
- (4) Intelligent temperature and humidity control energy-saving technology
Use the intelligent temperature and humidity control energy-saving technology to make sure that the room temperature and humidity are comfortable for human beings. It save more than 30% energy and makes human beings far away from diseases.
- (5) Intelligent liquid-spray protection technology
With the intelligent liquid-spray protection technology, units can calculate the current air injection dryness and control the liquid height, to accurately control the air injection dryness.
- (6) New generation CAN bus communication
Due to the latest communication method—CAN Bus Communication, system's anti-interference capability is stronger and the control on indoor units is more accurate, with higher reliability. Specialized shield wire is no more needed and ordinary communication wire can be applied in the construction, which has increased the installation flexibility.
- (7) Reliable low-temperature running
The controller uses the low temperature elements, which can run reliably at -35°C. The compressor can normally start up below -35°C.
- (8) Small floor area and easy installation
The floor area it occupies is the smallest one in the same capacity at the market.
- (9) Complete protection
Units are equipped with a series of protection to accurately identify errors and protect the units, which has ensured reliable and safe operation.

3.1.2 Features of Duct Type Indoor Unit

- ◆Flexible setting and even air supply
Duct can be connected and air outlet and return air inlet can be set flexibly
- ◆Convenient installation
Can be installed in the ceiling
- ◆With fresh air function to improve indoor air quality
Fresh air duct can be connected
- ◆Wide adjusting range of static pressure and air volume
Static pressure and air volume can be set according to actual requirements

3.1.3 Features of Wall Mounted Type Indoor Unit

◆ Filter can be cleaned

The filter is removable and can be cleaned for easy maintenance.

◆ Quiet design

High-efficiency cross flow blade and imported silence valve are adopted, which greatly reduce the noise of entire unit.

◆ One IDU with several wired controller and several IDUs with one wired controller

One IDU can be connected with several wired controllers in order to control one IDU from different location; meanwhile, several IDUs can be connected with one wired controller in order to achieve centralized control of 16 IDUs in maximum.

◆ Wide air supply range

The air supply range is wide, so that the wind can be delivered to each corner of the room naturally and evenly.

◆ Super cooling and heating function

Intelligent temperature control technology is adopted with super cooling and heating function, so that the room temperature can reach set temperature rapidly.

◆ I-feel function

When I-feel function is activated, the unit can detect the temperature around the user and adjust the temperature, so that the comfort of user is improved. (Remote controller shall be equipped)

◆ Panel is removable

The panel of indoor unit can be removed easily for convenient maintenance.

◆ CAN bus communication technology and auto addressing

The response of the system is quicker with more reliable communication; auto addressing, non-polar communication and free wiring are available.

◆ Multiple protections

Anti-freezing protection, temperature sensor malfunction protection, fan motor overload protection, auxiliary electric heating overheat protection (This function is not included in pure heat pump unit).

4 SPECIFICATIONS

4.1 Outdoor Unit

Model			GMV-36WL/B-T(U)	GMV-48WL/B-T(U)
Product Code			CN850W0380	CN850W0360
Cooling capacity	kW(Btu/h)		10.5(36000)	14.1(48000)
Heating capacity	kW(Btu/h)		13.2(45000)	15.8(54000)
Circulating air volume	m ³ /h		6000	6000
Noise	dB(A)		56	57
Refrigerant charge volume	Kg(oz)		6.5	6.5
Energy efficiency level	Level		1	1
Power supply			208/230V~60Hz	208/230V~60Hz
Rated power input	Cooling	kW	2.6	4.2
	Heating	kW	3.1	4.2
Unit Dimensions (mm/inch)(WxDxH)			900×340×1345mm(35.4×13.4×53.0inch)	
Package Dimensions (mm/inch)(WxDxH)			993×453×1500mm(39.3×18.0×59.6 inch)	
Compressor			QXAW-F518zX440C	
Water-proof level			IPX4	IPX4
Suitable climite			T1	T1
Connection pipe	Gas	mm/inch	φ15.9(5/8)	φ15.9(5/8)
	Liquid	mm/inch	φ9.52(3/8)	φ9.52(3/8)
	Connection Method		Flare connection	Flare connection
Net weight		Kg	134.4	134.4
Minimum NO. of connectable indoor units			2	2
Maximum NO. of connectable indoor units			5	6
Total capacity index of to be connected indoor units		Min	50	50
		Max	100	100

Note:

- ① . The technical parameters are changed along with the products' improvement; please refer to the nameplate of the unit for actual data.
- ② . Noise is tested in the semi-anechoic room, so it should be slightly higher in the actual operation due to environmental change.

4.2 Indoor Unit

4.2.1 Low Static Pressure Duct Type IDU

Model		GMV-ND07PLS/A-T(U)	GMV-ND09PLS/A-T(U)	GMV-ND12PLS/A-T(U)	GMV-ND14PLS/A-T(U)	GMV-ND18PLS/A-T(U)	GMV-ND22PLS/A-T(U)	
Product Code		CM810N0080	CM810N0090	CM810N0100	CM810N0120	CM810N0070	CM810N0110	
Cooling Capacity	Btu/h	7500	9500	12000	14000	18000	22000	
	kW	2.2	2.8	3.5	4.0	5.3	6.3	
Heating Capacity	Btu/h	8500	10500	13500	15000	20000	24000	
	kW	2.5	3.1	4.0	4.5	5.9	7.1	
Casing finish		Galvanized Steel plate						
Dimensions (W×D×H)	outline	mm	700×615×200	700×615×200	700×615×200	900×615×200	1100×615×200	1100×615×200
		inch	27-1/2×24-1/4×7-7/8	27-1/2×24-1/4×7-7/8	27-1/2×24-1/4×7-7/8	35-3/8×24-1/4×7-7/8	43-1/4×24-1/4×7-7/8	43-1/4×24-1/4×7-7/8
	Packaging	mm	893×743×305	893×743×305	893×743×305	1123×743×305	1323×743×305	1323×743×305
		inch	35-1/8×29-1/4×12	35-1/8×29-1/4×12	35-1/8×29-1/4×12	44-1/2×29-1/4×12	52×29-1/4×12	52×29-1/4×12
Net Weight	lbs.	51	51	51	60	69	69	
	kg	23	23	23	27	31	31	
Gross Weight	lbs.	64	64	64	73	86	86	
	kg	29	29	29	33	39	39	
Pipe Connection	Liquid Side	mm	Φ6.35	Φ6.35	Φ6.35	Φ6.35	Φ9.52	Φ9.52
		inch	Φ1/4	Φ1/4	Φ1/4	Φ1/4	Φ3/8	Φ3/8
	Gas Side	mm	Φ9.52	Φ9.52	Φ12.7	Φ12.7	Φ15.9	Φ15.9
		inch	Φ3/8	Φ3/8	Φ1/2	Φ1/2	Φ5/8	Φ5/8
	Drain Pipe	mm	Φ25	Φ25	Φ25	Φ25	Φ25	Φ25
		inch	Φ1	Φ1	Φ1	Φ1	Φ1	Φ1
Power supply		1-phase 208-230V 60Hz						
Fan	Type * Quantity		Centrifugal*2	Centrifugal*2	Centrifugal*2	Centrifugal*3	Centrifugal*4	Centrifugal*4
	Driving Mechanism		Direct-driven					
	Motor Type		BLDC					
	Motor Power Input	W	43	43	43	52	99	99
	Motor Running Current	A	0.3	0.3	0.3	0.5	0.7	0.7
	Airflow Rate(H/M/L)	CFM	265/235/150	265/235/150	325/265/205	410/353/265	590/470/355	590/470/355
		m ³ /h	450/400/250	450/400/250	550/450/350	700/600/450	1000/800/600	1000/800/600
	External	Default	in.W.G.	0.06	0.06	0.06	0.06	0.06
			Pa	15	15	15	15	15
	Static Pressure	Range	in.W.G.	0~0.12	0~0.12	0~0.12	0~0.12	0~0.12
Pa			0~30	0~30	0~30	0~30	0~30	
Sound Pressure Level(H/M/L)		dB(A)	31/29/25	31/29/25	32/30/27	33/31/28	35/33/30	
Heat Exchanger		Fenestrate plain film --hydrophilic film						
Air Filter		PP						
Refrigeration Control Device		EXV						
Protection Device		Fuse						

4.2.2 4-way Cassette Type IDU

Model		GMV-ND07T/ A-T(U)	GMV-ND09T/ A-T(U)	GMV-ND12T/ A-T(U)	GMV-ND15T/ A-T(U)	GMV-ND18T/ A-T(U)	
Product Code		CM500N0520	CM500N0530	CM500N0540	CM810N0130	CM500N0510	
Cooling Capacity	Btu/h	7500	9500	12000	15000	18000	
	kW	2.2	2.8	3.5	4.4	5.3	
Heating Capacity	Btu/h	8500	10500	13500	17000	20000	
	kW	2.5	3.1	4.0	5	5.9	
Casing finish		Galvanized Steel plate					
Dimensions (W×D×H)	Body outline	mm	840×840×190	840×840×240	840×840×240	840×840×240	840×840×240
		inch	33×33×7 1/2	33×33×9-1/2	33×33×9-1/2	33×33×9-1/2	33×33×9-1/2
	Body Packaging	mm	960×960×257	960×960×310	960×960×310	960×960×310	960×960×310
		inch	37-3/4×37-3/4×10-1/8	37-3/4×37-3/4×12-1/4	37-3/4×37-3/4×12-1/4	37-3/4×37-3/4×12-1/4	37-3/4×37-3/4×12-1/4
	Panel outline	mm	950×950×65	950×950×65	950×950×65	950×950×65	950×950×65
		inch	37-3/8×37-3/8×2-1/2	37-3/8×37-3/8×2-1/2	37-3/8×37-3/8×2-1/2	37-3/8×37-3/8×2-1/2	37-3/8×37-3/8×2-1/2
	Panel Packaging	mm	1030×1035×118	1030×1035×118	1030×1035×118	1030×1035×118	1030×1035×118
		inch	40-1/2×40-1/2×4-5/8	40-1/2×40-1/2×4-5/8	40-1/2×40-1/2×4-5/8	40-1/2×40-1/2×4-5/8	40-1/2×40-1/2×4-5/8
Net Weigh	Main Body	lbs.	50	58	58	58	58
		kg	22.5	26.5	26.5	26.5	26.5
	Panel	lbs.	15-3/8	15-3/8	15-3/8	15-3/8	15-3/8
		kg	7.0	7.0	7.0	7.0	7.0
Gross Weigh	Main Body	lbs.	64	75	75	75	75
		kg	29	34	34	34	34
	Panel	lbs.	24-1/4	24-1/4	24-1/4	24-1/4	24-1/4
		kg	11.0	11.0	11.0	11.0	11.0
Pipe Connections	Liquid Side	mm	Φ6.35	Φ6.35	Φ6.35	Φ6.35	Φ9.52
		inch	Φ1/4	Φ1/4	Φ1/4	Φ1/4	Φ3/8
	Gas Side	mm	Φ9.52	Φ9.52	Φ12.7	Φ12.7	Φ15.9
		inch	Φ3/8	Φ3/8	Φ1/2	Φ1/2	Φ5/8
	Drain Pipe	mm	Φ25	Φ25	Φ25	Φ25	Φ25
		inch	Φ1	Φ1	Φ1	Φ1	Φ1
Power supply		1-phase 208-230V 60Hz					
Fan	Type * Quantity		Centrifugal*1	Centrifugal*1	Centrifugal*1	Centrifugal*1	Centrifugal*1
	Driving Mechanism		Direct-driven	Direct-driven	Direct-driven	Direct-driven	Direct-driven
	Motor Type		BLDC	BLDC	BLDC	BLDC	BLDC
	Motor Power Input	W	48	48	48	48	59
	Motor Running Current	A	0.3	0.5	0.5	0.5	0.5
	Airflow Rate(H/M/L)	CFM	440/385/325	590/530/440	590/530/440	590/530/440	590/530/440
m ³ /h		750/650/550	750/650/550	750/650/550	750/650/550	1000/900/750	
Sound Pressure Level (H/M/L)	dB(A)	36/34/31	36/34/31	36/34/31	36/34/31	37/35/32	
Heat Exchanger		Fenestrate plain film --hydrophilic film					
Air Filter		PP	PP	PP	PP	PP	
Insulation Material		Foamed polystyrene					
Refrigeration Control Device		EXV	EXV	EXV	EXV	EXV	
Protection Device		Fuse	Fuse	Fuse	Fuse	Fuse	
Panel name		TC01	TC01	TC01	TC01	TC01	

Model		GMV-ND24T/ A-T(U)	GMV-ND30T/ A-T(U)	GMV-ND36T/ A-T(U)	GMV-ND42T/ A-T(U)	GMV-ND48T/ A-T(U)	
Product code		CM500N0550	CM500N0560	CM500N0570	CM500N0580	CM500N0590	
Cooling Capacity	Btu/h	24000	30000	36000	42000	48000	
	kW	7	8.8	10.6	12.3	14.1	
Heating Capacity	Btu/h	27000	34000	40000	47000	54000	
	kW	7.9	10	11.7	13.8	15.8	
Casing finish		Galvanized Steel plate					
Dimensions (W×D×H)	Body outline	mm	840×840×240	840×840×320	840×840×320	840×840×320	840×840×320
		inch	33×33×9-1/2	33×33×12-5/8	33×33×12-5/8	33×33×12-5/8	33×33×12-5/8
	Body Packaging	mm	960×960×310	960×960×394	960×960×394	960×960×394	960×960×394
		inch	37-3/4×37-3/4×12-1/4	37-3/4×37-3/4×15-1/2	37-3/4×37-3/4×15-1/2	37-3/4×37-3/4×15-1/2	37-3/4×37-3/4×15-1/2
	Panel outline	mm	950×950×65	950×950×65	950×950×65	950×950×65	950×950×65
		inch	37-3/8×37-3/8×2-1/2	37-3/8×37-3/8×2-1/2	37-3/8×37-3/8×2-1/2	37-3/8×37-3/8×2-1/2	37-3/8×37-3/8×2-1/2
	Panel Packaging	mm	1030×1035×118	1030×1035×118	1030×1035×118	1030×1035×118	1030×1035×118
		inch	40-1/2×40-1/2×4-5/8	40-1/2×40-1/2×4-5/8	40-1/2×40-1/2×4-5/8	40-1/2×40-1/2×4-5/8	40-1/2×40-1/2×4-5/8
Net Weight	Main Body	lbs.	58	72	72	72	72
		kg	26.5	32.5	32.5	32.5	32.5
	Panel	lbs.	15-3/8	15-3/8	15-3/8	15-3/8	15-3/8
		kg	7.0	7.0	7.0	7.0	7.0
Gross Weight	Main Body	lbs.	75	88	88	88	88
		kg	34	40	40	40	40
	Panel	lbs.	24-1/4	24-1/4	24-1/4	24-1/4	24-1/4
		kg	11.0	11.0	11.0	11.0	11.0
Pipe Connections	Liquid Side	mm	Φ9.52	Φ9.52	Φ9.52	Φ9.52	Φ9.52
		inch	Φ3/8	Φ3/8	Φ3/8	Φ3/8	Φ3/8
	Gas Side	mm	Φ15.9	Φ15.9	Φ15.9	Φ15.9	Φ15.9
		inch	Φ5/8	Φ5/8	Φ5/8	Φ5/8	Φ5/8
	Drain Pipe	mm	Φ25	Φ25	Φ25	Φ25	Φ25
		inch	Φ1	Φ1	Φ1	Φ1	Φ1
Power supply		1-phase 208-230V 60Hz					
Fan	Type * Quantity		Centrifugal*1	Centrifugal*1	Centrifugal*1	Centrifugal*1	Centrifugal*1
	Driving Mechanism		Direct-driven	Direct-driven	Direct-driven	Direct-driven	Direct-driven
	Motor Type		BLDC	BLDC	BLDC	BLDC	BLDC
	Motor Power Input	W	59	98	110	110	110
	Motor Running Current	A	0.5	0.8	0.9	0.9	0.9
	Airflow Rate(H/M/L)	CFM	695/590/470	885/800/650	1000/825/650	1095/885/680	1095/885/680
m ³ /h		1180/1000/800	1500/1350/1100	1700/1400/1100	1860/1500/1150	1860/1500/1150	
Sound Pressure Level(H/M/L)	dB(A)	38/36/33	40/38/35	41/38/36	43/41/38	43/41/38	
Heat Exchanger		Fenestrate plain film --hydrophilic film					
Air Filter		PP	PP	PP	PP	PP	
Insulation Material		Foamed polystyrene					
Refrigeration Control Device		EXV	EXV	EXV	EXV	EXV	
Protection Device		Fuse	Fuse	Fuse	Fuse	Fuse	
Panel name		TC01	TC01	TC01	TC01	TC01	

4.2.3 Features of Wall Mounted

Model		GMV-N07G/A3A-D(U)	GMV-N09G/A3A-D(U)	GMV-N12G/A3A-D(U)	GMV-N18G/A3A-D(U)	GMV-N24G/A3A-D(U)	
Product code		CM100N1480	CM100N1490	CM100N1500	CM100N1510	CM100N1520	
Cooling Capacity	Btu/h	7500	9500	12000	18000	24000	
	kW	2.2	2.8	3.5	5.2	7	
Heating Capacity	Btu/h	8500	11000	13500	20000	25500	
	kW	2.5	3.2	4	5.8	7.5	
Casing finish		Galvanized Steel plate					
Dimensions (W×D×H)	outline	mm	843×180×275	843×180×275	940×200×298	940×200×298	1008×221×319
		inch	33 1/5×7×10 5/6	33 1/5×7×10 5/6	37×7 7/8×11 3/4	37×7 7/8×11 3/4	39 2/3×8 5/7×12 5/9
	Packaging	mm	973×258×370	973×258×370	1068×288×395	1068×288×395	1131×398×328
		inch	38 1/3×10 1/6×14 4/7	38 1/3×10 1/6×14 4/7	42×11 1/3×15 5/9	42×11 1/3×15 5/9	44 1/2×15 2/3×13
Net Weight		lbs.	22	22	27.6	27.6	33.1
		kg	10	10	12.5	12.5	15
Gross Weight		lbs.	27.6	27.6	33.1	33.1	40.8
		kg	12.5	12.5	15	15	18.5
Pipe Connections	Liquid Side	mm	Φ6.35	Φ6.35	Φ6.35	Φ6.35	Φ9.52
		inch	Φ1/4	Φ1/4	Φ1/4	Φ1/4	Φ3/8
	Gas Side	mm	Φ9.52	Φ9.52	Φ12.7	Φ12.7	Φ15.9
		inch	Φ3/8	Φ3/8	Φ1/2	Φ1/2	Φ5/8
	Drain Pipe	mm	Φ17	Φ17	Φ17	Φ17	Φ17
		inch	Φ2/3	Φ2/3	Φ2/3	Φ2/3	Φ2/3
Power supply		1-phase 208-230V 60Hz					
Fan	Type * Quantity		Cross-flow *1	Cross-flow *1	Cross-flow *1	Cross-flow *1	Cross-flow *1
	Driving Mechanism		Direct-driven				
	Motor Type		PG				
	Motor Power Input	W	50	50	60	60	70
	Motor Running Current	A	0.2	0.2	0.21	0.21	0.31
	Airflow Rate(H/M/L)	CFM	295/247/206	295/247/206	370/324/283	370/324/283	440/353/294
m ³ /h		500/420/350	500/420/350	630/550/480	630/550/480	750/600/500	
Sound Pressure Level(H/M/L)	dB(A)	38/34/30	38/34/30	44/41/38	44/41/38	44/41/38	
Heat Exchanger		Fenestrate plain film -- hydrophilic film					
Air Filter		PP+10%BCM+FP03					
Insulation Material		Foamed polystyrene					
Refrigeration Control Device		EXV					
Protection Device		Fuse					

4.3 Operation range

Cooling	Outdoor temperature: (50~129.2°F)
Heating	Outdoor temperature: (-31~80.6°F)

5 PRODUCT CAPACITY CORRECTION

5.1 Instruction of Product Capacity Correction

Nominal cooling capacity and nominal heating capacity are tested under given conditions:

- (1) Rated cooling or heating condition.
- (2) No height difference between indoor unit and outdoor unit.
- (3) Short connection pipe.

If the three conditions above have changed, the cooling and heating capacity will change correspondingly and correction is needed.



5.2 Capacity Code

Instruction of capacity code:

GMV-36WL/B-(U) and GMV-48WL/B-(U) are identical in components, systems and structure, etc.

5.3 Capacity Correction Formula

5.3.1 Rated capacity of outdoor unit

Model		GMV-36WL/B-T(U)	GMV-48WL/B-T(U)
Rated cooling capacity	kW(Btu/h)	10.5(36000)	14.1(48000)
Rated heating capacity	kW(Btu/h)	13.2(45000)	15.8(54000)

5.3.2 Correction factor of indoor and outdoor temperature

(1) Correction factor of cooling capacity

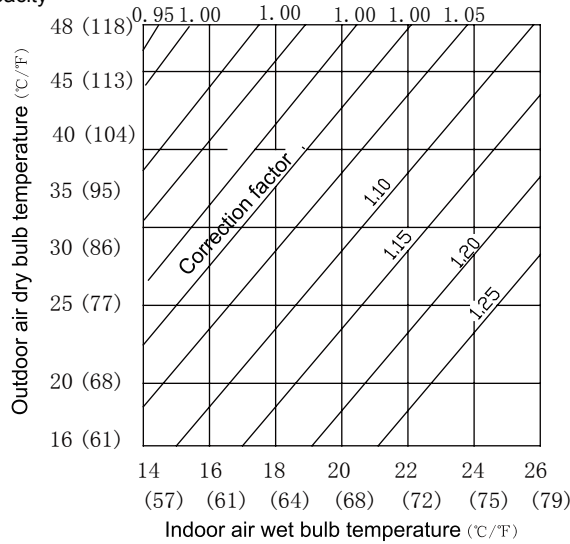

(2) Correction factor of heating capacity

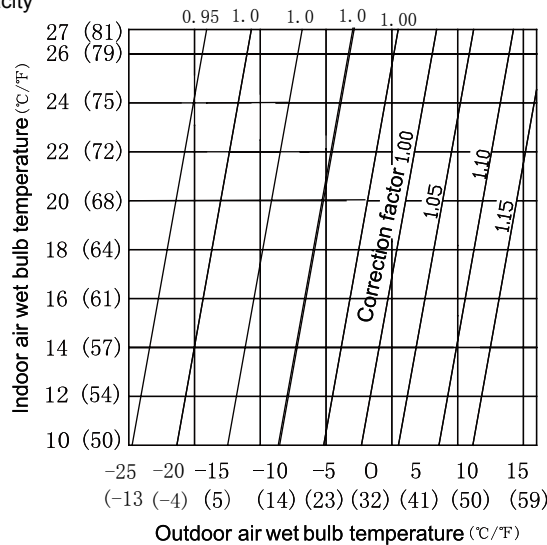

5.3.3 Correction factor of pipe length and height difference

(1) Symbol description:

Hp: Height difference in case indoor unit is below outdoor unit(m/feet);

Hm: Height difference in case indoor unit is above outdoor unit (m/feet);

L: Length of one-way equivalent pipe.

Below table shows the capacity variance ratio for 100% full load in standard working condition (thermostat setting is 16°C(61°F) for

cooling and 30°C(86°F) for heating).

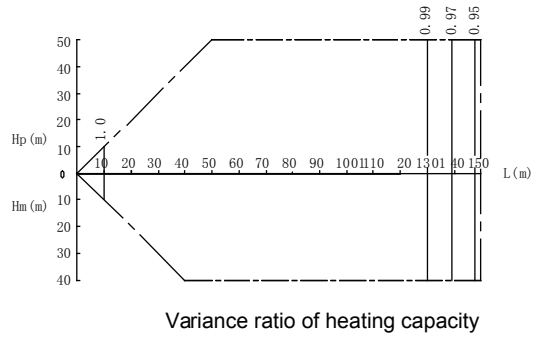
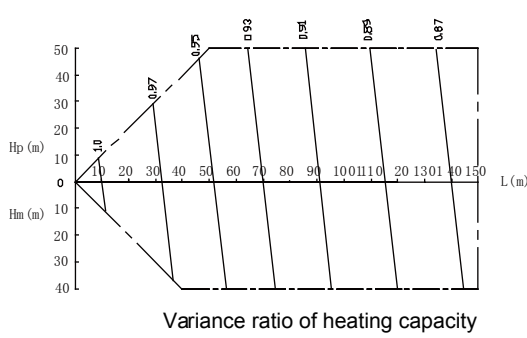

NOTE:

m	0	10	20	30	40	50	60	70	80	90	100	110	120	130	140	150
ft	0	33	66	98	131	164	197	230	262	295	328	361	394	427	459	492

6 PRINCIPAL OF OPERATION

Components in flowcharts are presented according to the following table:

Name	Compressor	4-way valve	Cut-off valve	One-way valve	Capillary tube
Symbol					
Name	Gas-liquid separator	Pressure switch	Pressure sensor	Axial-flow finned heat exchanger	Electronic expansion valve
Symbol					

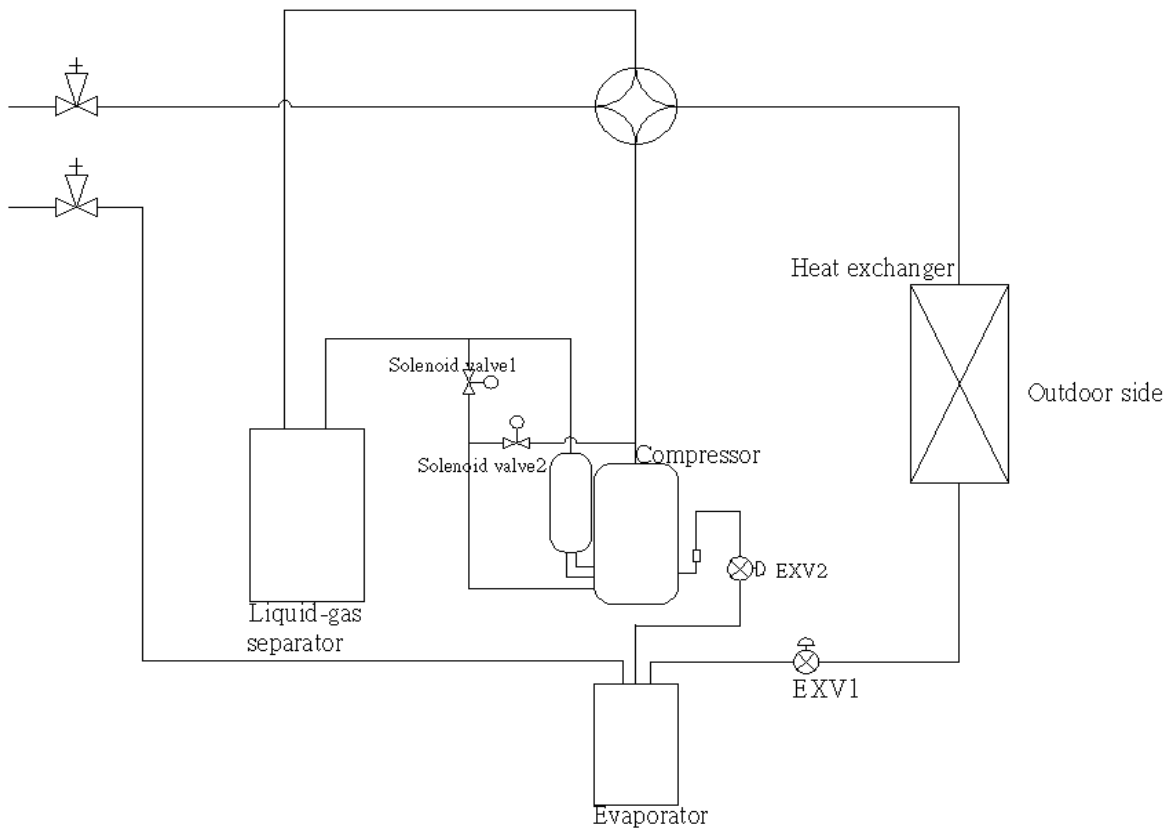

In cooling, the low-temperature and low-pressure refrigerant gas from each indoor heat exchanger will be merged and inhaled by the compressor and then become high-temperature and high-pressure gas, which will later be discharged into outdoor heat exchangers. By exchanging heat with outdoor air, refrigerant will turn to liquid and flow to each indoor unit via Y-type branch or manifold. Pressure and temperature of the refrigerant will then be lowered by throttle elements before it flows into indoor heat exchangers. After exchanging heat with indoor air, refrigerant will become low-temperature and low-pressure gas again and repeat the circulation so as to realize the cooling effect. In heating, 4-way valve will be energized to make refrigerant circulate in a reverse direction of cooling. Refrigerant will release heat in indoor heat exchangers (electric heating elements will also work under certain circumstance and release heat) and absorb heat in outdoor heat exchangers circularly so as to realize the heating effect.

CONTROL

CONTROL

1 Units' Control

1.1 Schematic diagram of units' control

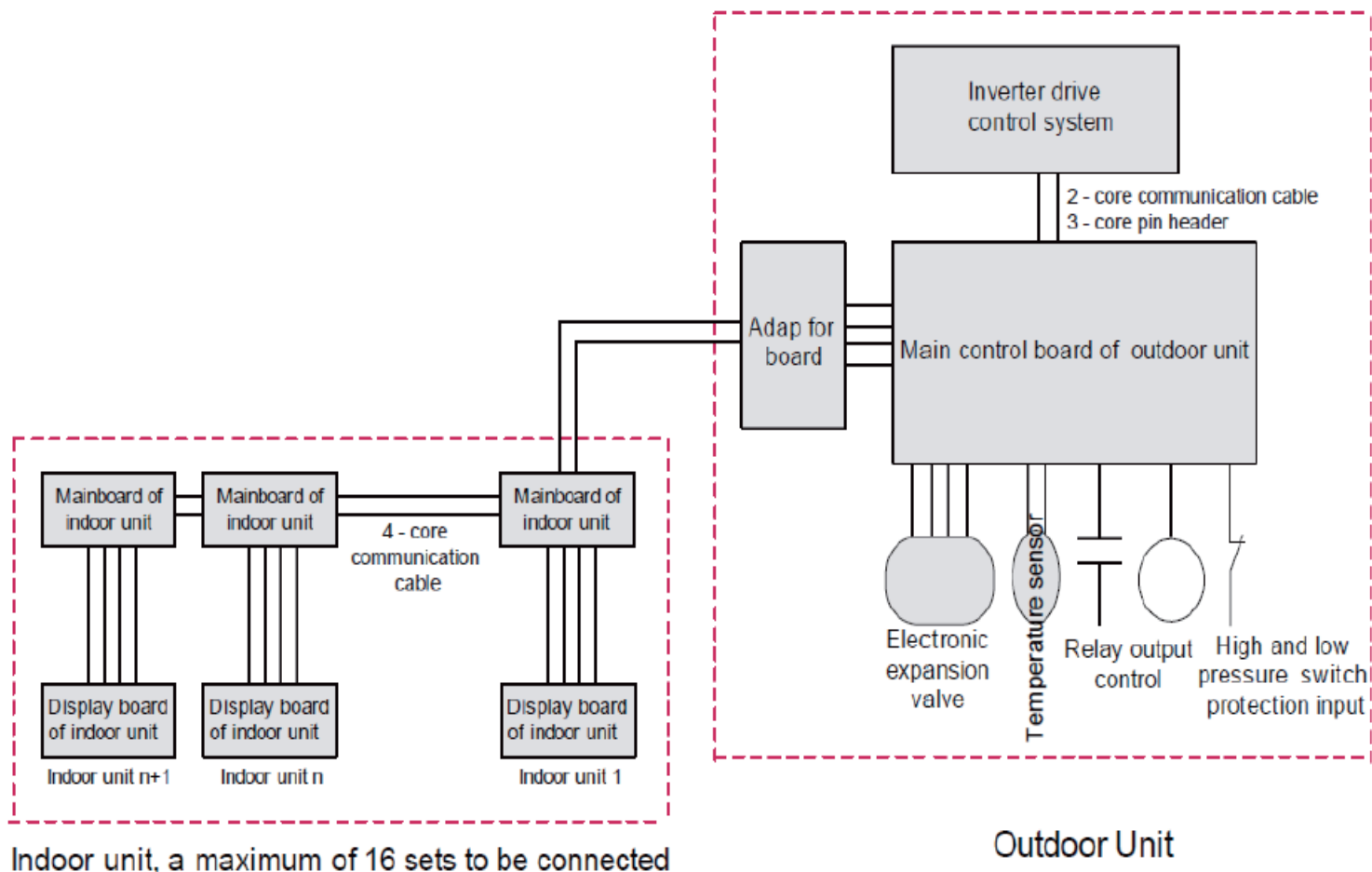

Air conditioning units can be divided into indoor unit and outdoor unit. A maximum of 16 sets of indoor units can be connected to an outdoor unit. 2-core (3-core pin header) communication cable is used for the connection between indoor unit and outdoor unit. Indoor unit is connected to display board via 4-core communication cable. In engineering installation, address dial-up of the display board and the mainboard of indoor unit shall be dialed. The address dial-up of the mainboard of indoor unit must be identical with that of the display board of the same indoor unit. Address dial-up of different indoor unit must vary. Multi VRF indoor unit is applicable to all digital or inverter outdoor units.

Controller of outdoor unit falls into two categories in terms of its function, i.e. main control system and inverter drive control system

2 Wired Controller

2.1 Control panel



Fig. 1.1 Appearance of wired controller

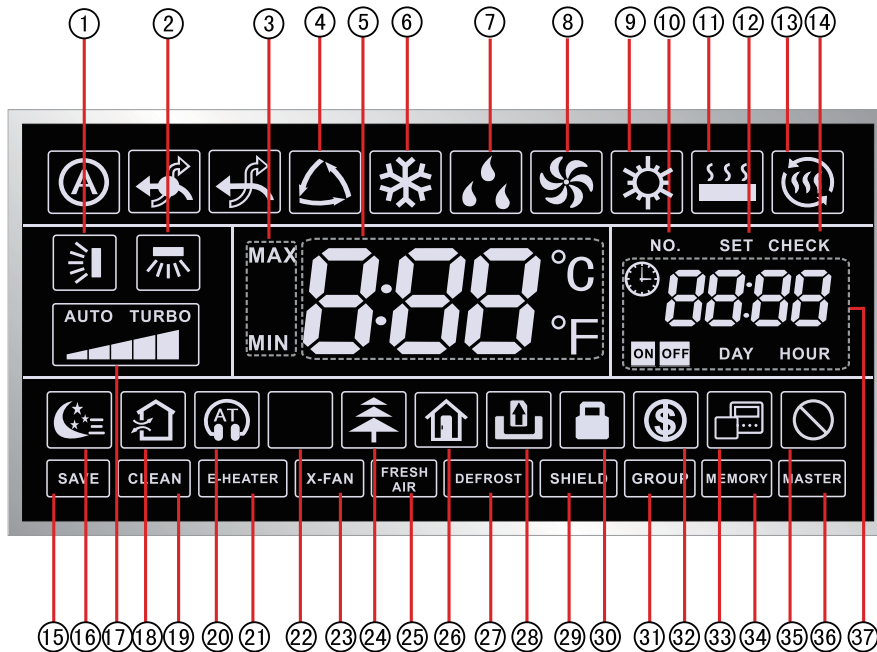

Fig. 1.2 LCD graphics of wired controller

◆ LCD Display Instruction

Table 1.1 LCD display instruction

No.	Symbols	Instructions
1		Up and down swing function
2		Left and right swing function
3		It's valid under Save mode and displays during setting process. Temperature lower limit for Cooling: Limit the minimum temperature value under Cooling or Dry mode. Temperature upper limit for Heating: Limit the maximum temperature value under Heating, Space Heating or 3D Heating mode.
4		Auto mode (Under Auto mode, the indoor units will automatically select their operating mode as per the temperature change so as to make the ambient comfortable.)
5		It shows the setting temperature value(In case the wired controller is controlling a Fresh Air Indoor Unit, then the temperature zone will display FAP)



6		Cooling mode
7		Dry mode
8		Fan mode
9		Heating mode
10		When inquiring or setting project number of indoor unit, it displays "NO." icon
11		Floor Heating mode (When Heating and Floor Heating simultaneously shows up, it indicates 3D Heating is activated.)
12		Display "SET" icon under parameter setting interface
13		Space Heating mode
14		Display "CHECK" icon under parameter view interface
15		Outdoor unit operates under Save mode/upper limit of system capacitor less 100%/remote Save status
16		Sleep status
17		Current set fan speed (including auto, low speed, medium-low speed, medium speed, medium-high speed, high speed and turbo seven status)
18		Air status
19		Remind to clean the filter
20		Quiet status (including Quiet and Auto Quiet two status)
21		Allow auxiliary electric heating On icon
22		Light On/Off function
23		X-fan function
24		Health function
25		Fresh air status
26		Out function
27		Outdoor unit defrosting status
28		Gate-control function
29		Shielding status
30		Child Lock status
31		One wired controller controls multiple indoor units
32		Save status of indoor unit
33		It indicates the current wired controller is the slave wired controller (address of wired controller is 02)
34		Memory status (The indoor unit resumes the original setting state after power failure and then power recovery)
35		Invalid operation
36		Current wired controller connects master indoor unit
37		Timer zone: Display system clock and timer status

Note: When wired controller is connected with different indoor units, some functions will be different

◆ Button Graphics

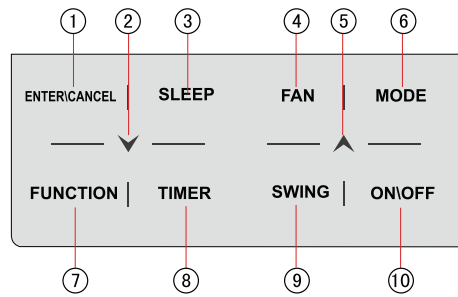

Fig. 1.3 Button graphics

2.2 Installation and removal

2.2.1 Installation dimensions

Unit:mm

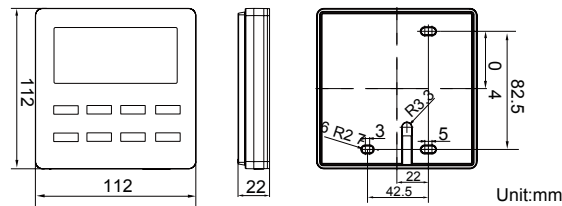

Fig.2.1.1 Dimension of wired controller

mm	112	22	2.7	3.3	5	42.5	40	82.5
inch	4.41	0.87	0.11	0.13	0.20	1.67	1.57	3.25

2.2.2 Installation method

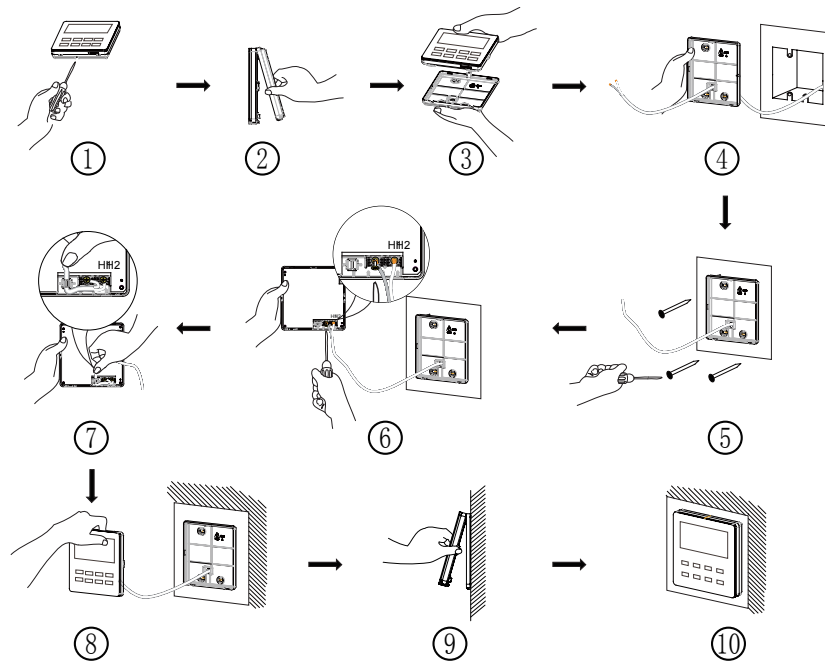

Fig. 2.2.2 Installation diagram for wired controller

Above is a simple installation method of wired controller. Please pay attention to the following:

- 1) Before installation, disconnect power of the indoor unit. Do not operate when power is connected.
- 2) 2-core twisted pair cable from the installation hole on the wall and lead it through the hole on the back plate of wired controller.
- 3) Place the wired controller on wall and secure its back plate on wall with screw M4X25.
- 4) Connect the 2-core twisted pair cable to terminal H1 and terminal H2. Tighten up the screws.
- 5) Stick the cable in the slot that is left of the terminals and buckle the wired controller's panel with its back plate.

⚠ CAUTION

If caliber of the communication cord is too large, which causes difficulty in leading or sticking the cord according to above point 2 and point 5, strip some of the sheath of the communication cable to meet the installation requirement.

2.2.3 Removal method

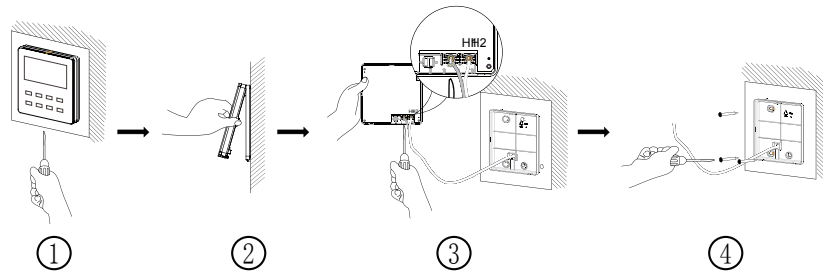

Fig.2.1.3 Removal of Wired Controller

2.2.4 Connection of communication cord

There are 4 ways to connect wired controller with indoor units' network:

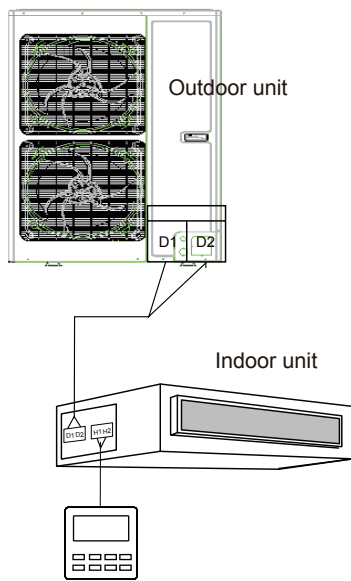

Fig. 2.2.4.1 One wired controller controls one indoor unit

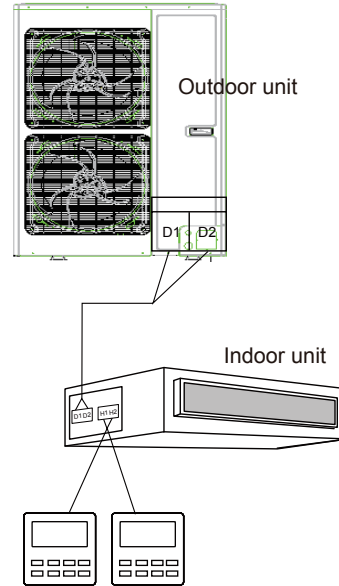

Fig. 2.2.4.2 Two wired controllers control one indoor unit

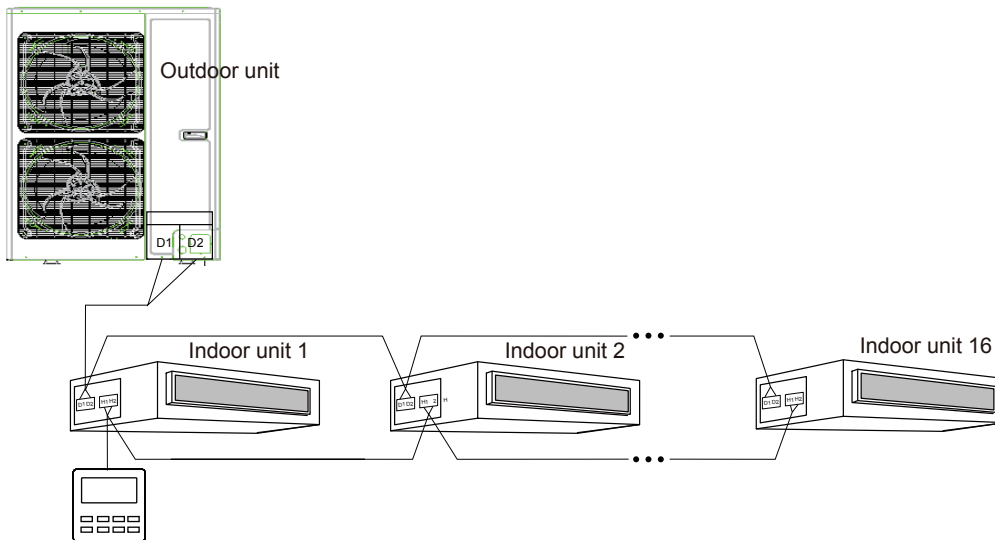

Fig. 2.2.4.3 One wired controller controls multiple indoor units simultaneously

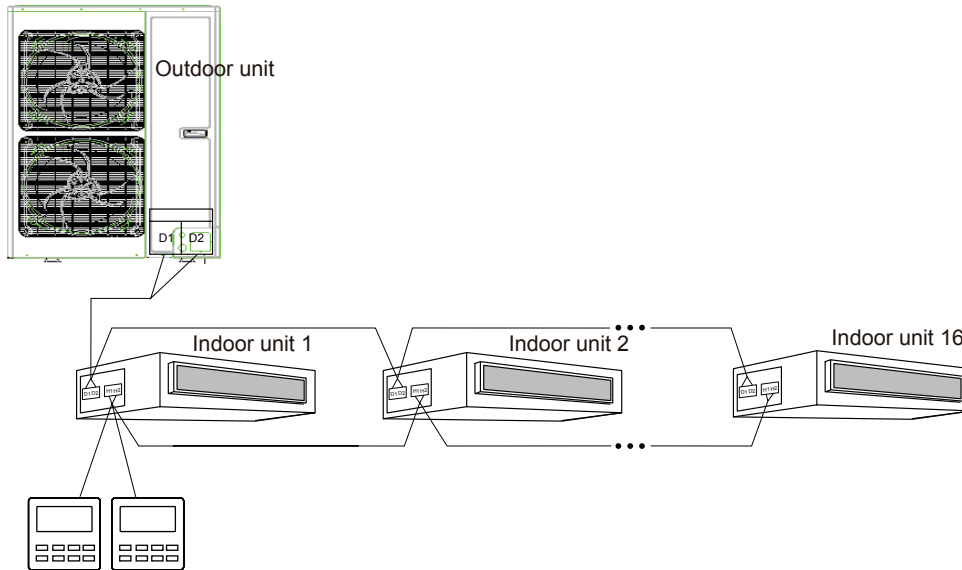

Fig. 3.6 Two wired controllers control multiple indoor units simultaneously

2.3 Engineering Test

1) Mater IDU Settings

In power-off status, press and hold the “MODE” button for five seconds to set the IDU connected with the current wired controller to master IDU. If the setting is successful, MASTER icon will be on.

2) User Parameter Query

Engineering Parameters can be queried in power-on or power-off status.

- (1) Press and hold the “FUNCTION” button for five seconds to enter the user parameter query interface. The temperature area display “C00” and “CHECK” is on.
- (2) Select a parameter code by pressing “^” or “v”
- (3) Press “ENTER/CANCEL” button to return to the upper-level menu till quitting parameter query.

The user parameter query list is as follows:

Parameter Code	Parameter Name	Parameter Range	View Method
C00	Parameter setting ingress	-	-
C01	Project number query of IDU and faulty IDU location	1-255: Project number of online IDU	<p>Operation method: In “C01” status, press “MODE” button to enter project number query of IDU. Press “^” or “v” to switch the IDU SN.</p> <p>Display mode: Temperature area: displays the fault of current IDU Timer area: displays project number of current IDU Special operations: After users press the “MODE” button to enter project number query, the buzzer of the IDU operated by the wired controller will ring till users quit “C01” query or</p>

			switch to the next IDU
C03	Indoor unit quantity query in the system network	1-80	Timer area: displays the number of IDUs in the system network.
C06	Preferential operation query	00: Common operation 01: Preferential operation	Operation method: In "C06" status, press MODE button to enter Preferential operation query interface. Press ^ or v to switch the IDU SN. Display mode: Temperature area: displays project number of current IDU Timer area: displays the preferential operation setting value of the current IDU
C07	Indoor environment temperature query	-	Operation method: In "C07" status, press MODE button to enter the indoor environment temperature query interface. Press ^ or v to switch the IDU SN. Display mode: Temperature area: displays project number of current IDU Timer area: displays the temperature value of the environment temperature sensor after replenishment.
C08	Prompt time query for air filter cleaning	4-416: days	Timer area: displays the prompt time query for air filter cleaning
C09	Wired controller address query	01, 02	Timer area: displays the address of the current wired controller
C11	Indoor unit quantity query in one-to-many mode	1-16	Timer area: displays the number of IDUs controlled by the wired controller
C12	Outdoor environment temperature query	-	Timer area: displays the temperature value of the environment temperature sensor of the master ODU.

Note:

- a. In parameter query status, FAN, TIMER, SLEEP, and SWING are invalid. By pressing the "ON/OFF" button, users can return to the main interface but not power on/off the unit.
- b. In parameter query status, signals of the remote controller are invalid.

3) User Parameter Settings

Engineering Parameters can be set in power-on or power-off status.

- (1) Press and hold the FUNCTION button for five seconds to enter the user parameter query interface. The temperature area displays C00. Press and hold the FUNCTION button for another five seconds to enter the

wired controller parameter setting interface. The temperature area displays "P00".

(2) Select a parameter code by pressing "▲" or "▼". Press the "MODE" button to switch to parameter value setting. The parameter value blinks. Adjust the parameter value by pressing "▲" or "▼" and press the "ENTER/CANCEL" to complete settings.

(3) Press "ENTER/CANCEL" button to return to the upper-level menu till quitting parameter settings.

The user parameter setting list is as follows:

Parameter Code	Parameter Name	Parameter Range	Default Value	Remark
P10	Master IDU settings	00: does not change the master/slave status of the current IDU. 01: sets the current IDU to master IDU	00	After the IDU connected with the current wired controller is successfully set to master IDU, "MASTER" on the wired controller is on.
P11	Infrared connection settings of wired controller	00: disabled 01: enabled	01	This setting can only be enabled through the master wired controller. When the infrared remote receiving function of wired controller is disabled, neither the master nor slave wired controller can receive remote signals. The wired controller can only be operated by pressing.
P13	Wired controller address settings	01: Master wired controller 02: Slave wired controller	01	When two wired controllers simultaneously control one or more IDUs, the two controllers should use different addresses. The slave wired controller (address:02) does not have the unit parameter setting function except its own address settings.
P14	Group-controlled IDU quantity settings	00: disabled 01-16: number of indoor units	01	This value is set based on the number of connected IDUs. If the current value is inconsistent with the actual number of group-controlled IDUs, an "L9" fault may occur.
P30	Static pressure settings for indoor fan	Type 1: 03.04.05.06.07 Type 2: 01.02.03.04.05.06.07.08.09	05	After identifying the IDU type, the wired controller only displays the available static pressure levels. 1. The static pressure levels fall into five levels and nine levels for VRF IDUs. The wired controller only displays the static pressure levels matched with the identified IDU type. 2. When the HBS network consists of IDUs with both five and nine static



				pressure levels according to the maximum control principle. If the static pressure levels received by the IDU from wired controller, remote controller, or remote monitoring system exceed the setting range, the limit value prevails. 3. During power-on and synchronization the setting value of static pressure levels is determined by setting of the IDU.
P31	High-ceiling installation	00: standard-ceiling installation height 01: high-ceiling installation height	00	
P33	Timer function settings	00: common timing 01: time-point timing	00	
P34	Repeating validity for time-point timing	00: single timing 01: repeated everyday	00	This setting is valid only when the timer function is set to time-point timing.
P37	Cooling setting temperature in automatic mode	17°C ~ 30°C	25°C	Cooling setting temperature - heating setting temperature ≥ 1 C.
P38	Heating setting temperature in automatic mode	16°C ~ 29°C	20°C	Note: The two settings are still valid in remote shielding status.
P43	Preferential operation settings	00: common operation 01: preferential operation	00	When power supply is insufficient, users are allowed to power on/off the IDU set with preferential operation and other IDUs are forcibly powered off. A fault code is displayed on the IDU that is forcibly powered off.
P46	Accumulated time clearing for air filter cleaning	00: not cleared 01: cleared	00	

Note:

- a. In parameter query status, FAN, TIMER, SLEEP, and SWING are invalid. By pressing the "ON/OFF" button, users can return to the main interface but not power on/off the unit.
- b. In parameter query status, signals of the remote controller are invalid.

2.4 Operation Instructions

1) On/Off

Press ON/OFF button to turn on the unit.

Press ON/OFF button again to turn off the unit.

The interfaces of On/Off status are shown as follow:

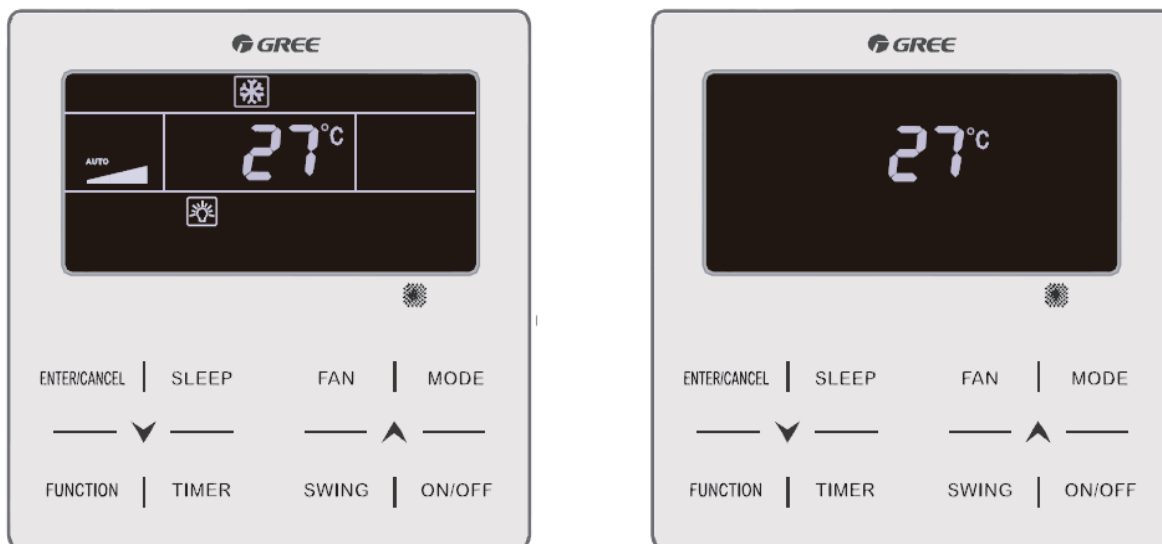

2) Mode Setting

Under On status, pressing MODE button can set mode circularly as:

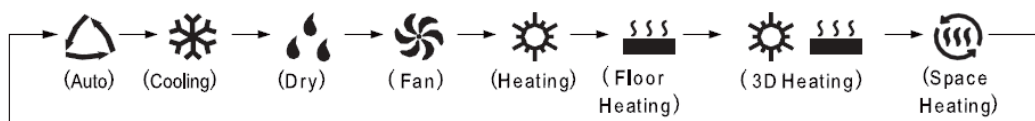

OR

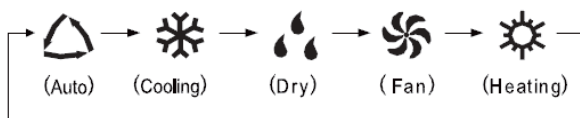

Note:

- ① There will be different mode with different model of the unit. The wired controller will select the range of setting mode according to the model of indoor unit
- ② Only in master indoor unit that AUTO mode can be set.
- ③ Under the AUTO mode, when the indoor unit is cooling, and will be on; when the indoor unit is heating, and will be on.

3) Temperature Setting

Pressing or button in On status increases or decreases set temperature by 1°C; holding or button increases or decreases set temperature by 1°C every 0.3s.

In Cooling, Fan, Heating, Floor Heating, 3D Heating or Space Heating mode, temperature setting range is 16°C~30°C.

In Dry mode, the temperature setting range is 12°C, 16°C~30°C. In Dry mode, when temperature is 16°C,



continuously press “V” button twice to decrease temperature to 12°C (when Save function is activated, the temperature in Dry mode can't be adjusted to 12°C and the setting range is “lowest temperature in Save mode” ~ 30°C).

Note:

- ① Under Auto mode or Out function is activated, the setting temperature can not be adjusted by pressing “^” or “V”
- ② When the wired controller is connected with a Fresh Air Indoor Unit, setting temperature won't be displayed and can't be adjusted via “^” or “V” button. The air outlet temperature in cooling or heating can only be set in the parameter setting status.

4) Fan Speed Setting

Under On status, pressing FAN button can set fan speed circularly as:

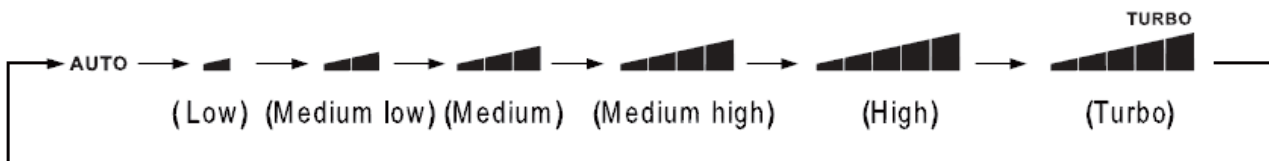

Note: Under the DRY mode, the fan will be kept running at the low speed and the fan speed isn't adjustable

5) Timer setting

The wired controller is equipped with two kinds of timer: general timer and clock timer. General timer is factory defaulted setting. Please refer to parameter setting

a. General Timer

Unit On/Off after a desired hour can be set through general timer.

Set Timer: when timer is not set, press TIMER button to enter timer setting and “HOUR” icon is blinking. Press “^” or “V” button to adjust timer time. Press TIMER button to save the setting and then exit setting.

Cancel Timer: when timer is set, press TIMER button to cancel it.

Timer setting range: 0.5~24h. Pressing “^” or “V” button increases or decreases timer time by 0.5h; holding “^” or “V” button increases or decreases timer time by 0.5h every 0.3s.

In unit On status, timer Off setting is shown as follow:

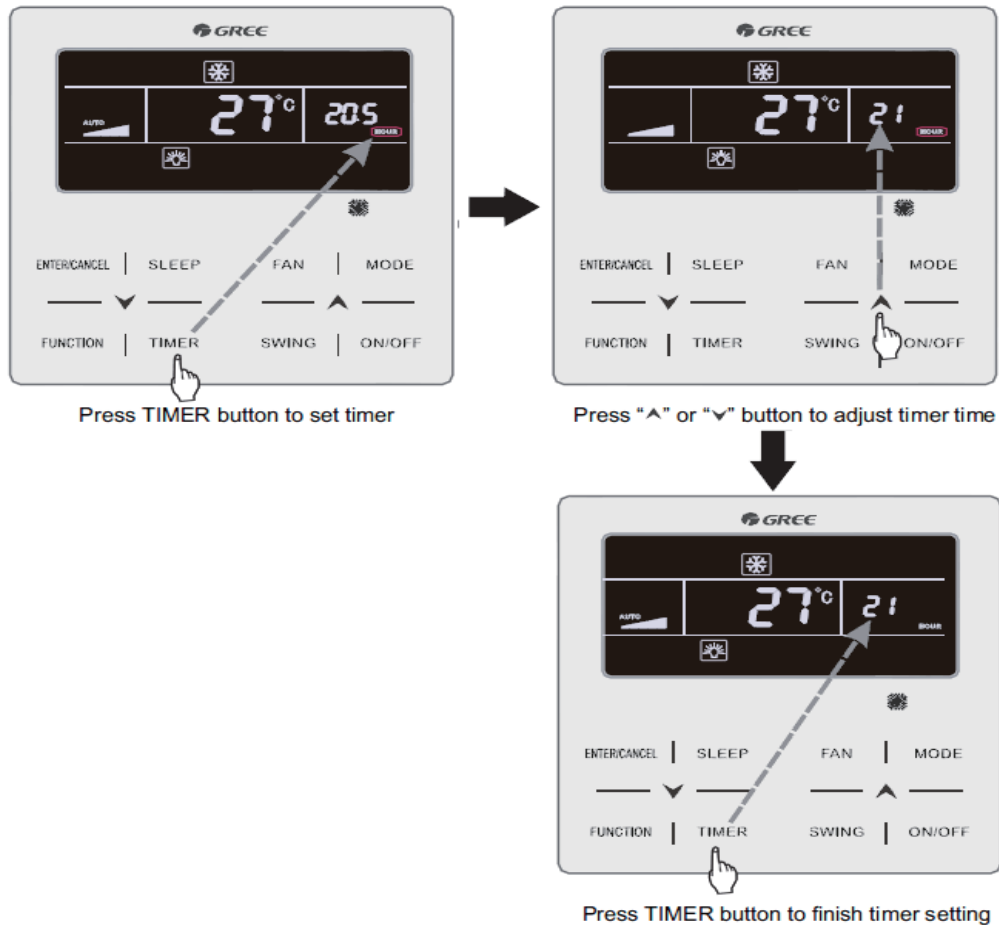

b. Clock Setting Clock display: when the timer setting way is clock timer, timer zone displays system clock in unit On and Off status. "🕒" icon is bright and the clock can be set at this time.

Clock setting: long press TIMER button for 5s to enter clock setting and "🕒" icon is blinking. Pressing "▲" or "▼" button increases or decreases clock time by 1min; holding "▲" or "▼" button for 5s increases or decreases clock time by 10min; Press ENTER/CANCEL button or TIMER button to save the setting and then exit setting.

c. Clock Timer

Unit On/Off at a certain time can be set through clock timer.

Set Timer:

- (1) Press TIMER button to enter timer on setting and the "ON" icon is blinking;
- (2) Press "▲" or "▼" button to adjust unit On time. Press ENTER/CANCEL button to finish setting;
- (3) Before pressing ENTER/CANCEL button, pressing TIMER button can save unit On time and then switch to unit Off time setting with "OFF" icon blinking;
- (4) Press "▲" or "▼" button to adjust unit Off time. Press ENTER/CANCEL button to finish setting;

Cancel Timer:

Press TIMER button to enter timer setting; press TIMER button again to switch to the setting of unit ON time or unit Off time; press ENTER/CANCEL button to cancel timer.

Pressing “^” or “v” button increases or decreases timer time by 1min; holding “^” or “v” button for 5s increases or decreases timer time by 10min.

Clock Timer setting is shown as follow:

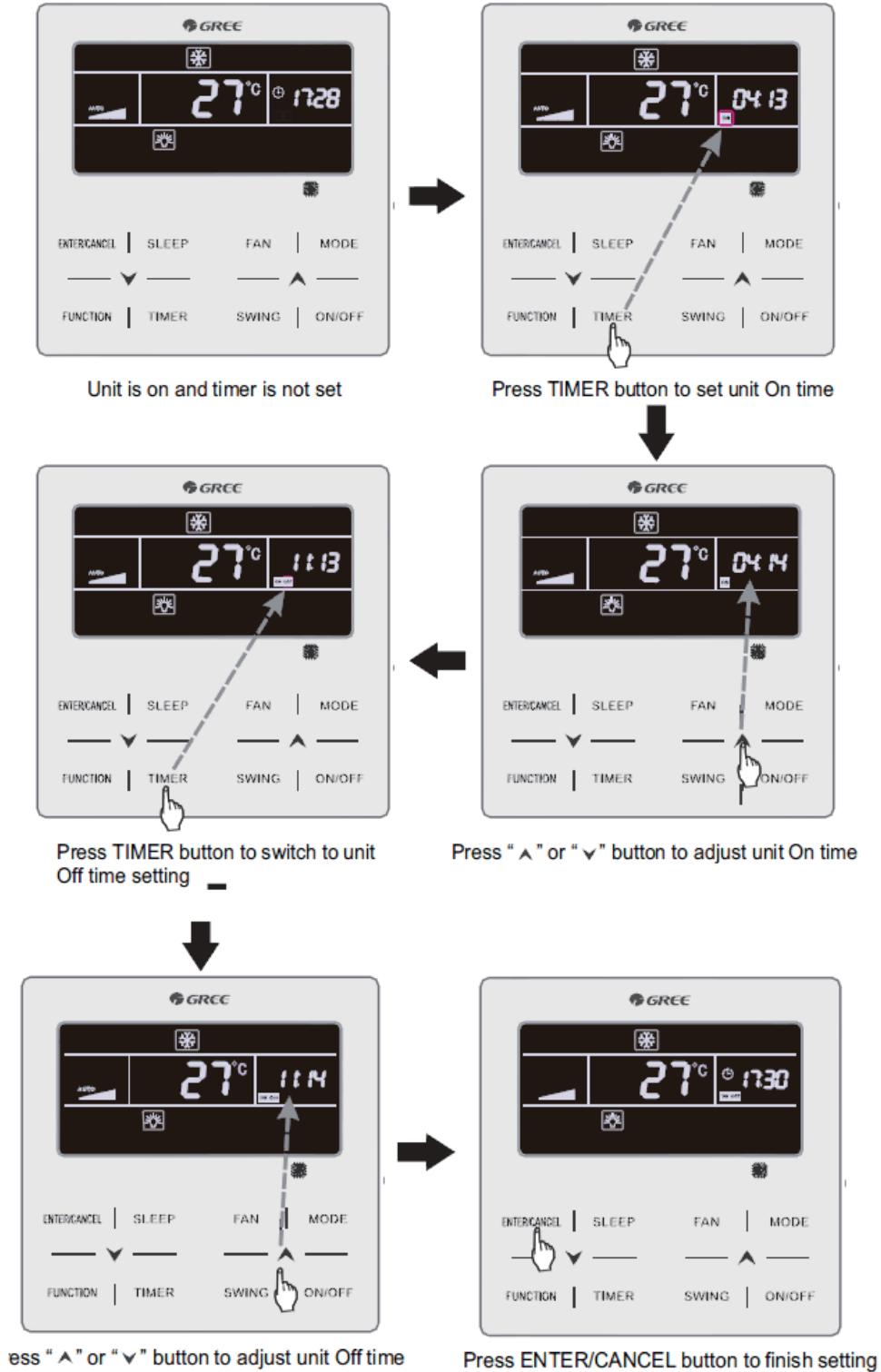

6) Swing Setting In unit on status, up & down swing function and left & right swing function can be set.

(1) Up & down swing function

Up & down swing function has two modes: simple swing mode and fixed-angle swing mode. In unit off status, press “SWING” button and ▲ button together for 5 seconds to switch between simple swing mode and fixed-angle swing mode. Up & down swing icon  will blink during switching.

- a. When simple swing mode is set in unit on status, press “SWING” button to start or stop up & down swing.
- b. When fixed-angle swing mode is set in unit on status, press “SWING” button to adjust swing angle circularly as below:

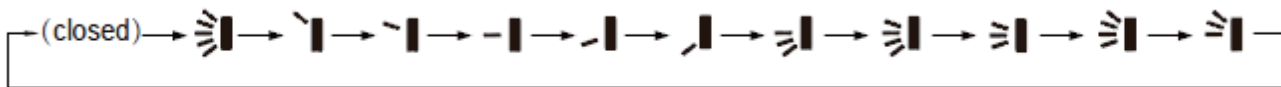

(2) Left & right swing function



Start left & right swing: In unit on status, press “FUNCTION” button to switch to left & right swing function with left & right swing icon  blinking, and then press “ENTER/CANCEL” button to start left & right swing.

When left & right swing is activated, left & right swing  will be bright.

Cancel left & right swing: When left & right swing is activated, press “FUNCTION” button to switch to left & right swing with left & right swing icon  blinking, and then press “ENTER/ CANCEL” button to cancel left & right swing.

7) Quiet Setting

Quiet Function: decrease the noise of indoor unit and achieve the quiet effect. Quiet function has two modes: Quiet mode and Auto Quiet mode. It is available only in Auto, Cooling, Dry, Fan, Heating, 3D heating, Space heating mode.

Turn on Quiet Function: press FUNCTION button to turn to Quiet function and then  icon or auto quiet icon  is blinking. At this moment, press “^” or “v” button to switch between quiet and auto quiet, and then press ENTER/CANCEL button to activate.

Turn off Quiet Function: press FUNCTION button to turn to Quiet function and then press ENTER/CANCEL button to cancel Quiet function.

The setting of Quiet function is shown as follow:



Press FUNCTION button to turn to Quiet function



Press "▲" or "▼" button to switch between Quiet and Auto Quiet



Press ENTER/CANCEL button to activate Quiet function

8) Sleep Setting

Sleep Function: in this mode, the unit will operate according to the preset sleep curve to provide comfortable sleep environment.

Turn on/off Sleep Function: in unit On status, press SLEEP button to activate or cancel Sleep function.

When Sleep function is activated, "☾" icon is bright and quiet or auto quiet mode is also activated.

When Sleep function is closed, if quiet function is activated before starting Sleep function, only sleep function

is closed while quiet function is still activated;

Under Auto, Fan or Floor Heating mode, this Sleep function is not available.

9) Air Setting

Air Function: Adjust the amount of indoor fresh air to improve air quality and keep indoor air fresh.

Turn on Air Function: When unit is on or off, press FUNCTION button and select Air...  icon will blink and the unit enters into Air setting. Temperature zone shows the level of Air setting, which can be adjusted by pressing “^” or “v” button. The adjustment range is 1~10. Press ENTER/ CANCEL button to turn on Air function.

Turn off Air Function: When Air function is on, press FUNCTION button to select Air, then press ENTER/CANCEL button to cancel this setting.

The setting of Air function function is shown as follow:

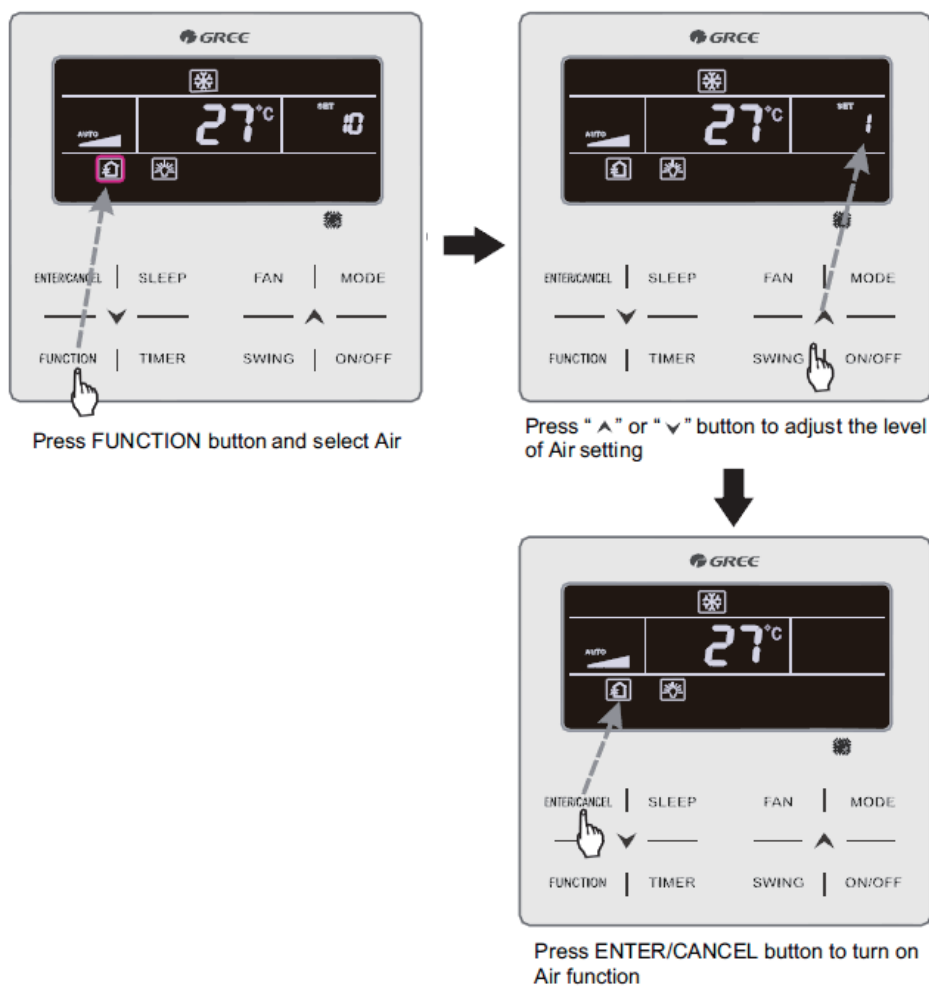

10) Light On/Off Setting

Light On/Off Function: Light of indoor unit can be turned on or off.

Turn on the Light: When unit is on or off, press FUNCTION button to select Light function.  icon will blink. Press ENTER/CANCEL to turn on the light.

Turn off the Light: When light of indoor unit is on, press FUNCTION button to select Light. Then press ENTER/CANCEL to turn off the light.

Note:

When there is no button operation on the wired controller or no remote control signal is received for 20s continuously:

- ① If Light function is activated, the back light of LCD will turn to half bright.
- ② If Light function is off, the back light of LCD will be off.

11) Save Setting



Save Function: Air conditioner can be operated in small temperature range by setting the minimum temperature under Cooling and Dry modes and setting maximum temperature under Heating, 3D Heating and Space Heating modes. Thus, energy saving can be realized.

Save Setting:

Save Setting for Cooling: When unit is on and under Cooling or Dry mode, press FUNCTION button to select Save function.  icon will blink and MIN icon lit up. Press "▲" button to adjust to the minimum temperature. Press ENTER/CANCEL button to activate this function.

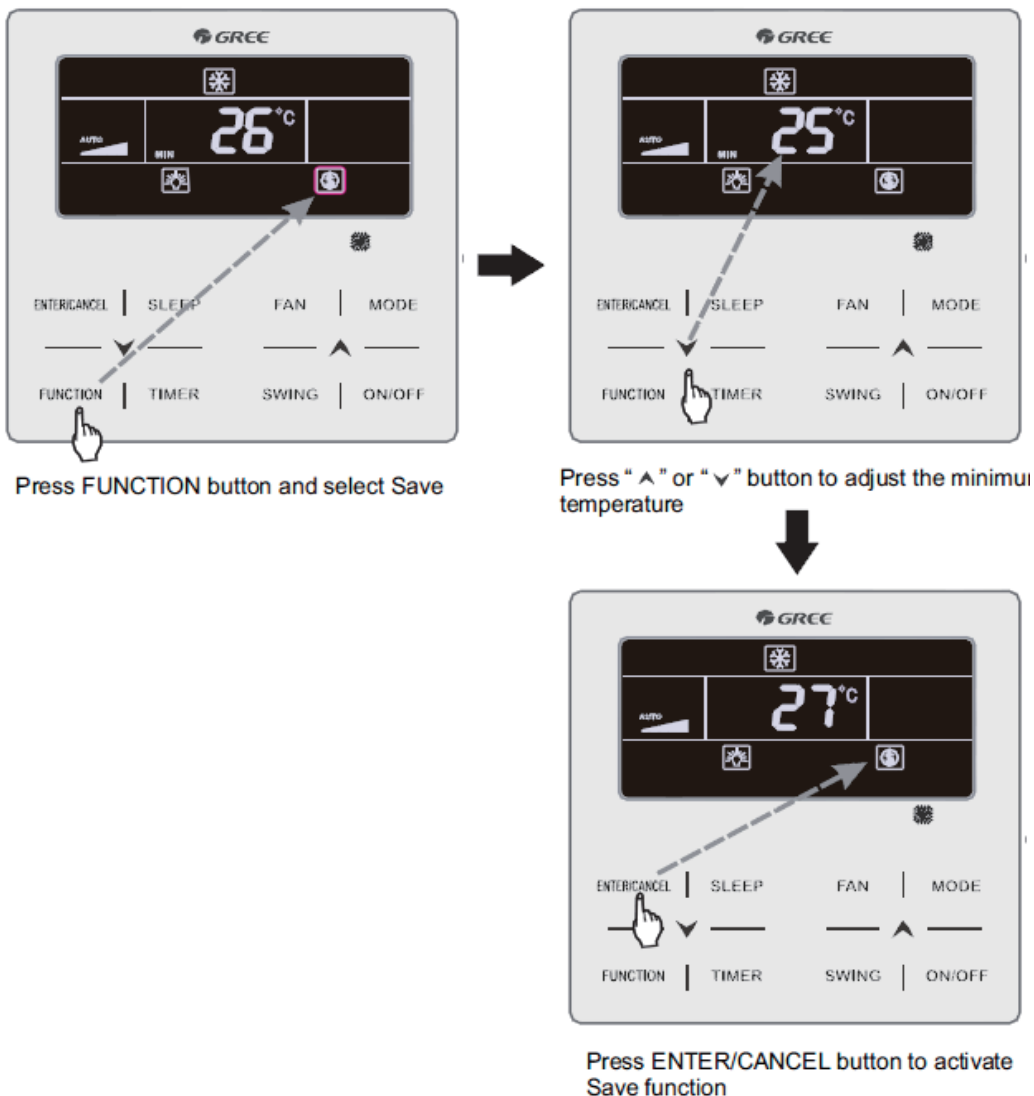
The setting of Save function is shown as follow:





Save Setting for Heating: When unit is on and under Heating, 3D Heating and Space Heating modes, press FUNCTION button to select Save function.  icon will blink and MAX icon lit up. Press  button to adjust the MAXIMUM temperature. Press ENTER/CANCEL button to turn on this function.

Turn off Save Function: Press FUNCTION button and select Save function.  icon blinks. Then press ENTER/CANCEL button to cancel this setting.

12) Filter Clean Reminder Setting

Filter Clean Reminder Function: Unit will remember its own operating time. When the setting time is up, this function will remind you to clean the filter. A dirty filter will result in bad heating and cooling performance, abnormal protection, bacteria gathering, etc.

Turn on Filter Clean Reminder Function: When unit is on, press FUNCTION button and select Filter Clean Reminder.  icon will blink. Press  button to adjust the cleaning level, of which the range is 00, 10-39. Press ENTER/CANCEL to turn on this function.

Turn off Filter Clean Reminder Function: When unit is on and this function has been turned on, press FUNCTION button and select Clean. Then  icon will blink. Set the cleaning level as 00 and press ENTER/CANCEL function to cancel this setting.

When Filter Clean Reminder time is up,  icon will light up to remind you to clean the filter. Press FUNCTION button to turn to Filter Clean Reminder Function, then press SWING/ ENTER to cancel reminding, and it will retime according to the original cleaning level. The clean reminding can be cancel only when you didn't reset the cleaning level under the setting of Filter Clean Reminder Function.

The setting of Filter Clean Reminder function is shown as follow:

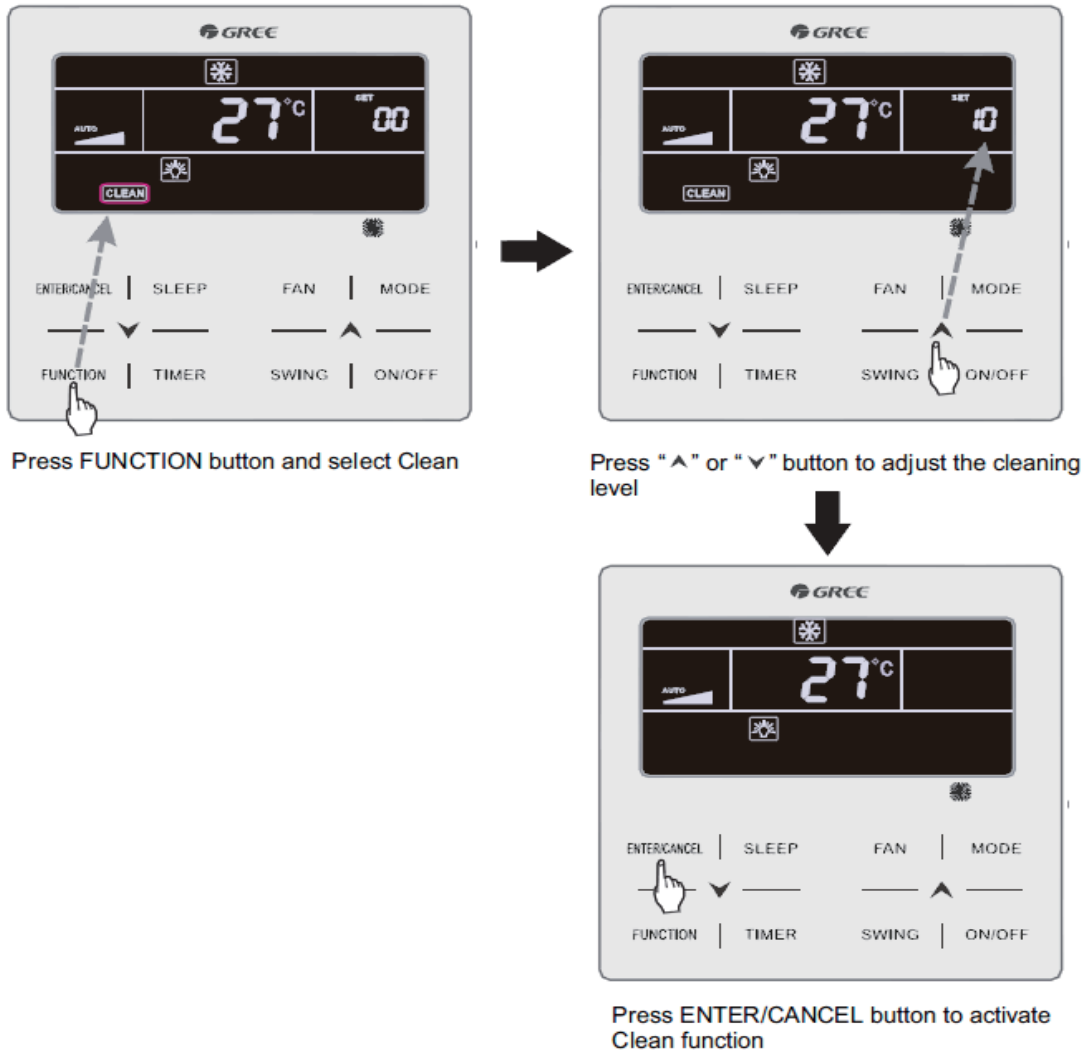

Note:

Description on cleaning level: When setting the Filter Clean Reminder Function, timer zone will display 2 digits, of which the former indicates the pollution degree of operating place and the latter indicates the operating time of indoor unit. There are 4 types of situations:

Cleaning Level	Description of Levels
Turn off Clean Reminder	Timer zone shows 00
Slight Pollution	The former digit shows 1 while the latter one shows 0, which indicates the accumulating operating time is 5500 hours. Each time the latter digit increases 1, the operating time increases 500 hours. When it reaches 9, it means the operating time is 10000 hours
Medium Pollution	The former digit shows 2 while the latter one shows 0, which indicates the accumulating operating time is 1400 hours. Each time the latter digit increases 1, the operating time increases 400 hours. When it reaches 9, it means the operating time is 5000 hours

Heavy Pollution	The former digit shows 3 while the latter one shows 0, which indicates the accumulating operating time is 100 hours. Each time the latter digit increases 1, the operating time increases 100 hours. When it reaches 9, it means the operating time is 1000 hours.
-----------------	--

13) X-fan Setting

X-fan Function: If unit is turned off under Cooling or Dry mode, the evaporator of indoor unit will be dried off automatically to prevent bacteria and mould from gathering.

Turn on X-fan: When unit is on or under Cooling or Dry mode, press FUNCTION button to select X-fan.  icon will blink. Then press ENTER/CANCEL button to turn on this function.

Turn off X-fan: When X-fan function is on, press FUNCTION button to select X-fan.  icon will blink. Then press ENTER/CANCEL button to turn off this function.

14) Out Setting

Out Function: This is used to maintain indoor temperature so that unit can realize fast heating after it is turned on. This function can only be used under Heating mode.



Turn on Out Function: Under Heating mode, press FUNCTION button to select Out.  icon will blink. Then press ENTER/CANCEL button to turn on this function.

Turn off Out Function: When this function is on, press FUNCTION button to select Out.  icon will blink. Then press ENTER/CANCEL button to turn off this function.





15) Remote Shield Function

Remote Shield Function: Remote monitor or central controller can disable the relevant functions of wired controller so as to realize the function of remote control.

Remote Shield Function includes all shield and partial shield. When All Shield function is on, all controls of the wired controller are disabled. When Partial Shield function is on, those controls that are shielded will be disabled.

When the remote monitor or central controller activates Remote Shield on the wired controller,  icon will show. If user wants to control through the wired controller,  icon will blink to remind that these controls are disabled.

16) Child Lock Function

When unit is turned on normally or turned off,   button together for 5 seconds will turn on Child Lock function.  will show on the display. Press   together again for 5 seconds to turn off this function.

All the other buttons will be disabled when Child Lock function is on.

17) Gate-control Function



When there is Gate-control System, user can insert a card to turn on the unit or pull off a card to turn off the unit. When the card is re-inserted, the unit will recover the operation as state in memory. When the card is pulled off (or improperly inserted),  icon will show.

2.5 Error display

When there occurs any error during operation, the temperature display zone on the wired controller will show error codes. If several errors happen at the same time, error codes will show on the display repeatedly.

Note: If error occurs, please turn off the unit and send for professionals to repair.

The display of Outdoor Unit High Pressure Protection when unit is on is shown as follow:



3 Remote Controller

(1) Remote controller YAD1F

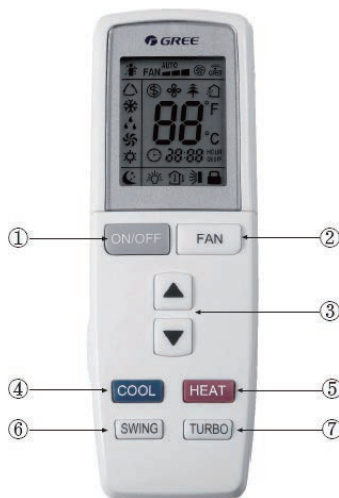

1) Button name and function introduction (outside)

No.	Button name	Function
1	ON/OFF	Turn on or turn off the unit
2	FAN	Set fan speed
3	▲/▼	Set temperature and time
4	COOL	Set cooling function
5	HEAT	Set heating function
6	SWING	Set swing status
7	TURBO	Set turbo function

2) Button name and function introduction (inside)

No.	Button name	Function
1	MODE	Set operation mode
2	TIMER ON	Set timer on function
3	TIMER OFF	Set timer off function
4	LIGHT	Set light function
5	I FEEL	Set I FEEL function
6	X-FAN	Set X-FAN function
7	TEMP	Switch temperature displaying type on the unit's display
8	HEALTH	Set health function
9	CLOCK	Set clock of the system
10	SLEEP	Set sleep function

(2) Remote controller YV1L1



No.	Button name	Function
1	ON/OFF	Turn on or turn off the unit
2	FAN	Set fan speed
3	▲/▼	Set temperature and time
4	MODE	Set operation mode
5		Set quiet function
6		Set health function and air function
7		Set left&right swing status
8		Set up&down swing status
9	X-FAN	Set X-FAN function
10	TIMER ON	Set timer on function
11	TIMER OFF	Set timer off function
12	SAVE	Set energy-saving function
13	SLEEP	Set sleep function
14	LIGHT	Set light function
15	CLOCK	Set clock of the system
16	I FEEL	Set I FEEL function
17	TEMP	Switch temperature displaying type on the unit's display



INSTALLATION

INSTALLATION

1 Engineering Installation Preparation and Notice

1.1 Installation notice

Personnel and property safety are highly concerned during the entire installation process. Installation implementation must abide by relevant national safety regulations to ensure personnel and property safety.

All personnel involved in the installation must attend safety education courses and pass corresponding safety examinations before installation. Only qualified personnel can attend the installation. Relevant personnel must be held responsible for any violation of the regulation.

1.2 Installation key points and importance

VRF air conditioning systems use refrigerant, instead of other agent, to directly evaporate to carry out the system heat. High level of pipe cleanness and dryness is required in the system. Since various pipes need to be prepared and laid out onsite, carelessness or maloperation during installation may leave impurities, water, or dust inside refrigerant pipes. If the design fails to meet the requirement, various problems may occur in the system or even lead to system breakdown.

Problems that usually occur during installation are as follows:

No.	Installation Problem	Possible Consequence
1	Dust or impurities enter into the refrigeration system.	Pipes are more likely to be blocked; air conditioning performance is reduced; compressor wear is increased or even hinder the normal operation of the system and burn the compressor.
2	Nitrogen is not filled into the refrigerant pipe or insufficient Nitrogen is filled before welding.	Pipes are more likely to be blocked; air conditioning performance is reduced; compressor wear is increased or even hinder the normal operation of the system and burn the compressor.
3	The vacuum degree in the refrigerant pipe is insufficient.	The refrigeration performance is reduced. The system fails to keep normal operation due to frequent protection measures. When the problem getting serious, compressor and other major components can be damaged.
4	Water enters into the refrigeration system.	Copper plating may appear on the compressor and reduce the compressor efficiency with abnormal noise generated; failures may occur in the system due to ice plug.
5	The refrigerant pipe specifications do not meet the configuration requirements.	Smaller configuration specifications can increase the system pipe resistance and affect the cooling performance; larger configuration specifications are waste of materials and can also reduce the cooling performance.
6	Refrigerant pipe is blocked.	The cooling performance is reduced; in certain cases, it may cause long-term compressor operating under overheat conditions; the lubricating effect can be affected and the compressor may be burnt if impurities were mixed with the lubricating oil.
7	Refrigerant pipe exceeds the limit.	The loss in pipe is considerable and the unit energy efficiency decreases, which are harmful for long-term running of the system.
8	Incorrect amount of refrigerant is filled.	The system cannot correctly control the flow allocation; the compressor may be operating under over-heating environment or running when the refrigerant flows back to the compressor.
9	The refrigerant pipe leaks.	Insufficient refrigerant circulating in the system decreases the cooling performance of the air conditioner. Long-term operation under such circumstance may cause an overheating compressor or even damage the compressor.
10	Water drainage from the condensate water pipe is not smooth.	Residual water in IDUs can affect the normal operation of the system. The possible water leakage can damage the IDU's decoration.
11	The ratio of slop for condensate water pipe is insufficient or the condensate water pipe is incorrectly connected.	Reverse slop or inconsistent connection of condensate water pipe can hinder the smooth drainage and cause leakage of the IDU.
12	The air channel is improperly fixed.	The air channel will deform; vibration and noise occur during unit operating.
13	The guide vane of air channel is not reasonably manufactured.	Uneven air quantity allocation reduces the overall performance of the air conditioner.



14	The refrigerant pipe or condensate water pipe does not meet the insulation requirement.	Water can easily condensate and drip to damage the indoor decoration, or even trigger the protection mode of system due to overheating operation.
15	The installation space for IDU is insufficient.	Since there is a lack of space for maintenance and checking, indoor decoration might need to be damaged during such operation.
16	The IDU or the location of the air outlet or return air inlet is not designed reasonably.	The air outlet or return air inlet may be short-circuited, thus affecting the air conditioning performance.
17	The ODU is improperly installed.	The ODU is difficult to be maintained; unit exhaust is not smooth, which reduces the heat exchanging performance or even prevent the system from normal operation; in addition, the cold and hot air for heat exchange and the noise may annoy people in surrounding areas.
18	Power cables are incorrectly provided.	Unit components may be damaged and potential safety hazard may occur.
19	Control communication cables are incorrectly provided or improperly connected.	The normal communication in the system fails or the control over IDUs and ODUs turn in a mess.
20	Control communication cables are not properly protected.	The communication cables are short-circuited or disconnected, and the unit cannot be started up due to communication failure.

2 Installation Materials Selection

The materials, equipment and instruments used during air conditioning engineering construction must have certifications and test reports. Products with fireproof requirements must be provided with fireproof inspection certificates and must meet national and relevant compulsory standards. If environmentally-friendly materials are to be used as required by customers, all such materials must meet national environmental protection requirement and be provided with relevant certificates.

2.1 Refrigerant piping

- (1) Material requirement: Dephosphorization drawing copper pipe for air conditioners;
- (2) Appearance requirement: The inner and outer surface of pipe should be smooth without pinhole, crack, peeling, blister, inclusion, copper powder, carbon deposition, rust, dirt or severe oxide film, and without obvious scratch, pit, spot and other defects.
- (3) Test report: Certifications and quality test reports must be provided.
- (4) The tensile strength must be at least 240 kgf/mm².
- (5) Specifications requirement.

R410A Refrigerant System		
OD (mm/inch)	Wall Thickness (mm)	Model
Φ6.35(1/4)	≥0.8	0
Φ9.52(3/8)	≥0.8	0
Φ12.70(1/2)	≥0.8	0
Φ15.9(5/8)	≥1.0	0
Φ19.05(3/4)	≥1.0	0

- (6) After the inner part of the copper pipe is cleaned and dried, the inlet and outlet must be sealed tightly by using pipe caps, plugs or adhesive tapes.

2.2 Condensate water pipe

- (1) Pipes that can be used for air conditioner drainage include: water supplying UPVC pipe, PP-R pipe, PP-C pipe, and HDG steel pipe;
- (2) All relevant certificates and quality test reports are provided.
- (3) Requirements for specifications and wall thickness
Water supplying UPVC pipe: Φ32mm×2mm, Φ40mm×2mm, Φ50mm×2.5mm;
HDG steel pipe: Φ25mm×3.25mm, Φ32mm×3.25mm, Φ40mm×3.5mm, Φ50mm×3.5mm.
- (4) Requirements for specifications and wall thickness
Water supplying UPVC pipe: Φ32mm×2mm, Φ40mm×2mm, Φ50mm×2.5mm;
HDG steel pipe: Φ25mm×3.25mm, Φ32mm×3.25mm, Φ40mm×3.5mm, Φ50mm×3.5mm.

2.3 Insulation material

- (1) Rubber foam insulation material;
- (2) Flame retardancy level: B1 or higher;
- (3) Refractoriness: at least 120oC;
- (4) The insulation thickness of condensate water pipe: at least 10 mm;
- (5) When the diameter of copper pipe is equal to or greater than Φ15.9 mm, the thickness of insulation material should be at least 20 mm; when the diameter of copper pipe is less than 15.9 mm, the thickness of insulation material should be at least 15 mm.

2.4 Communication cable and control cable

NOTICE!: For air conditioning units installed in places with strong electromagnetic interference, shielded wire must be used as the communication cables of the IDU and wired controller, and shielded twisted pairs must be used as the communication cables between IDUs and between the IDU and ODU.

Communication cable selection for ODU and IDUs.

Wire Type	Communication Cables Between IDU and Indoor (Outdoor) Unit L(m)	Number of Wire Pieces x Wire Diameter (mm ²)	Wire Standard	Remark
Common sheath twisted pair copper core (RVV)	L≤1000	≥2×0.75	GB/T 5023.3-2008	If the wire diameter is enlarged to 2×1mm ² , the overall communication length can reach 1500 m.

Communication cable selection for IDU and wired controller

Wire Type	Total Length of Communication Cables of the IDU and Wired Controller L(m)	Number of Wire Pieces x Wire Diameter (mm ²)	Wire Standard	Remark
Common sheath twisted pair copper core (RVV)	L≤250	≥2×0.75	GB/T 5023.3-2008	communication length cannot exceed 250 m.

2.5 Power cable

Only copper conductors can be used as power cables. The copper conductors must meet relevant national standard and satisfy the carrying capacity of unit.

2.6 Hanger rod and support

- (1) Hanger rod: M8 or M10;
- (2) U-steel: 14# or above;
- (3) Angle steel: 30mm×30mm×3mm or above;
- (4) Round steel: Φ10mm or above.

3 Installation of outdoor unit

3.1 Check before installation

- (1) Before installation, please check the power cord if it complies with the power supply requirement on the nameplate. Make sure the power supply is safe.
- (2) This air conditioner must be properly grounded through the receptacle to avoid electric shock. The ground wire shouldn't be connected with gas pipe, water pipe, lightning arrester or telephone line.
- (3) Maintain good air circulation to avoid lacking oxygen.
- (4) Read this manual carefully before installation.

3.2 Selection of installation site

- (1) Select a location which is strong enough to hold unit's weight so that unit can stand still and erect.
- (2) Make sure the unit is not exposed to sun and rain. And the location can resist dust, typhoon and earthquake.
- (3) Please keep the unit away from inflammable, explosive and corrosive gas or waste gas.
- (4) Make sure the location has space for heat exchange and maintenance so that unit can operate reliably with good ventilation.
- (5) ODU and IDU should stay as close as possible to shorten the length of refrigerant pipe and reduce bend angles.
- (6) Select a location which is out of children's reach. Keep the unit away from children.

3.3 Carrying and installing outdoor unit

When carrying the outdoor unit, hang the unit in four directions with two sufficient ropes. In order to avoid excursion from the center, the angle of ropes must be smaller than 40° during hanging and moving.

3.4 Installation notices

- ◆ In order to ensure proper operation, the selection of installation site must conform to the following principle:
- ◆ The discharged air of outdoor unit will not flow back and there is sufficient space around the unit for maintenance;
- ◆ The installation site must be well ventilated to ensure sufficient air intake and discharge. Make sure there is no obstacle at the air inlet and air outlet. If there is any obstacle, please remove it;
- ◆ The installation site shall be able to withstand the weight of outdoor unit and capable for soundproof and vibration. The air outlet and noise of unit will not affect neighbors;
- ◆ The hanging of outdoor unit must use appointed hanging hole. Pay attention to protect the unit during hanging and installation. Prohibit hitting the sheet metal to avoid rust in the future.
- ◆ Avoid direct sunlight;
- ◆ The rain and condensation water can be drained out smoothly;

- ◆ The outdoor unit will not be embedded by the snow and not affected by garbage and oil smog;
- ◆ The installation of outdoor unit shall adopt rubber damping pad or spring damper to reduce noise and vibration;
- ◆ The installation dimension shall accord with the installation requirement of this manual and the outdoor unit must be fixed at the installation site;
- ◆ The installation shall be done by professional technicians.

3.5 Fixing and damping of unit

The outdoor unit shall be fixed with 4 M12 bolts and closely contacted with the foundation. Otherwise, big vibration and noise will be caused.

The outdoor unit shall be fixed firmly. The rubber board with thickness over 20mm or corrugated rubber damping pad shall be applied between the unit and foundation.

3.6 Outline dimension and position of installation hole

When carrying the outdoor unit, hang the unit in four directions with two sufficient ropes. In order to avoid excursion from the center, the angel of ropes must be smaller than 40° during hanging and moving.

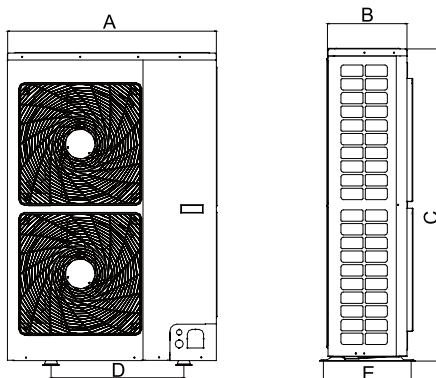

Unit:mm(inch)

Model	A	B	C	D	E
GMV-36WL/B-T(U)	900(35-3/8)	340(13-3/8)	1345	572(22-1/2)	378
GMV-48WL/B-T(U)			(53)		(15)

3.7 Installation space requirement

If all sides of the ODU (including the top) are surrounded by walls, process according to the following requirements for installation space:

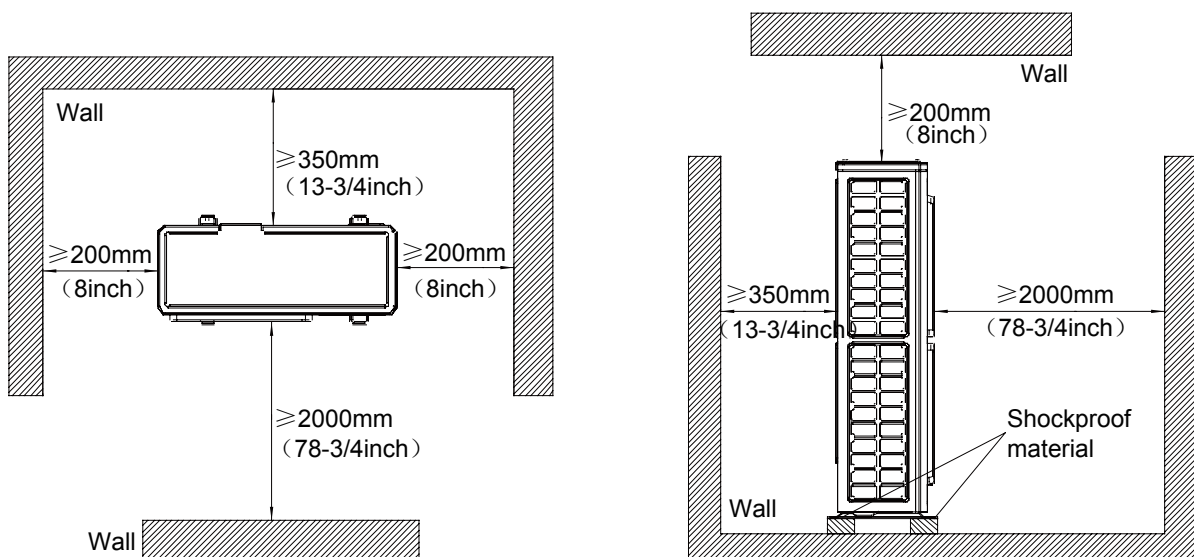

4 Installation of indoor Unit

4.1 Installation of quiet design duct type indoor unit

4.1.1 Low Static Pressure Duct Type Unit

The following diagram is applicable for units with the cooling capacity ranging from 7 k Btu/h to 22 k Btu/h.

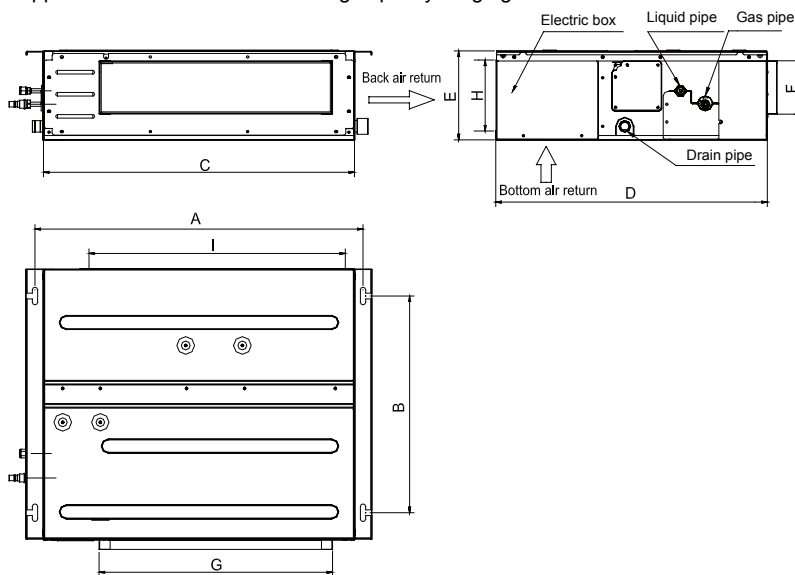

The following table lists the detailed dimensions.

Unit: mm(inch)

Model \ Item	A	B	C	D	E	F	G	H	I
GMV-ND07PLS/A-T(U) GMV-ND09PLS/A-T(U) GMV-ND12PLS/A-T(U)	742 (29-1/5)	491 (19-1/3)	700 (27-5/9)	615 (24-1/5)	200 (7-7/8)	121 (4-3/4)	528 (20-4/5)	161 (6-1/3)	580 (22-5/6)
GMV-ND14PLS/A-T(U)	942 (37)	491 (19-1/3)	900 (35-3/7)	615 (24-1/5)	200 (7-7/8)	121 (4-3/4)	728 (28-2/3)	161 (6-1/3)	780 (30-5/7)
GMV-ND18PLS/A-T(U) GMV-ND22PLS/A-T(U)	1142 (45)	491 (19-1/3)	1100 (43-1/3)	615 (24-1/5)	200 (7-7/8)	121 (4-3/4)	928 (36-1/2)	161 (6-1/3)	980 (38-4/7)

4.1.2 Installation space

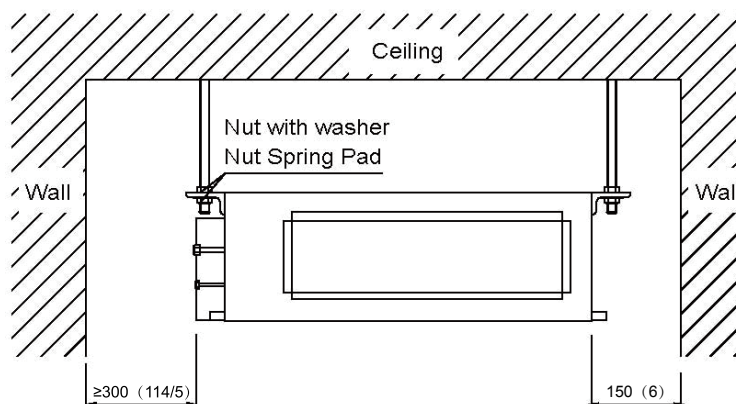

4.1.3 Installation notice

(1) Installation dimension (refer to the outline dimension in the figure)

(2) Installation foundation

Make sure the top hanging rod, ceiling and building structure have sufficient strength to withstand the weight of unit.

(3) Installation site and environment

Keep the unit from insolation and rain;

Keep the unit from fire, flammable objects, corrosive gas or exhaust gas;

Please reserve ventilation space;

Please reserve sufficient space for maintenance;

Please take proper measures to reduce noise and vibration.

(4) Electrical installation of unit

All electrical installation must be done by professionals according to national and local laws and regulations.

The unit must be grounded reliably. Please connect wire according to the wiring diagram on the unit.

4.2 Four-way Cassette Indoor Unit

4.2.1 Requirements for external dimensions and installation and maintenance spaces

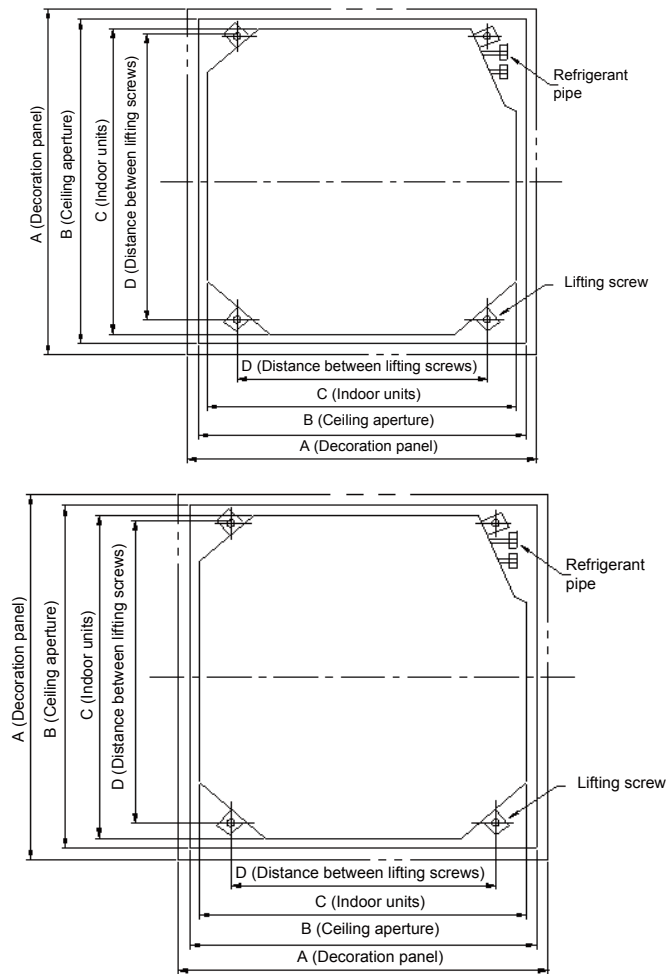

Unit: mm(inch)

Model	A	B	C	D	E	G	H
GMV-ND07T/A-T(U)	950 (37-2/5)	890 (35)	840 (33)	680 (26-7/9)	780 (30-5/7)	65 (2-5/9)	210 (8-1/4)
GMV-ND09T/A-T(U) GMV-ND12T/A-T(U) GMV-ND15T/A-T(U) GMV-ND18T/A-T(U) GMV-ND24T/A-T(U)	950 (37-2/5)	890 (35)	840 (33)	680 (26-7/9)	780 (30-5/7)	65 (2-5/9)	260 (10-1/4)
GMV-ND30T/A-T(U) GMV-ND36T/A-T(U) GMV-ND42T/A-T(U) GMV-ND48T/A-T(U)	950 (37-2/5)	890 (35)	840 (33)	680 (26-7/9)	780 (30-5/7)	65 (2-5/9)	340 (13-2/5)

4.3 Installation of wall-mounted indoor unit

4.3.1 Outline and installation dimension

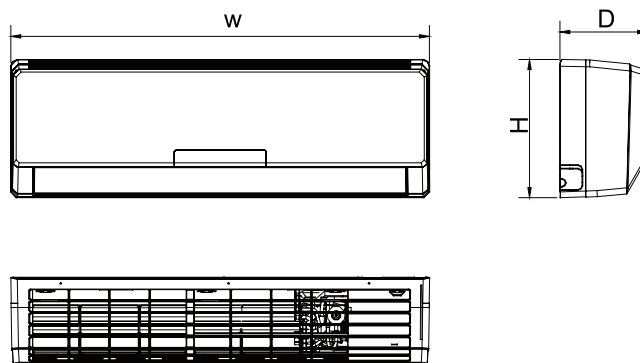

Unit: mm(inch)

Model	W	H	D
GMV-N07G/A3A-D(U) GMV-N09G/A3A-D(U)	843(33-1/5)	275(10-5/6)	180(7)
GMV-N12G/A3A-D(U) GMV-N18G/A3A-D(U)	940(37)	298(11-3/4)	200(7-7/8)
GMV-N24G/A3A-D(U)	1008(39-2/3)	221(8-5/7)	319(12-5/9)

4.3.2 Installation space

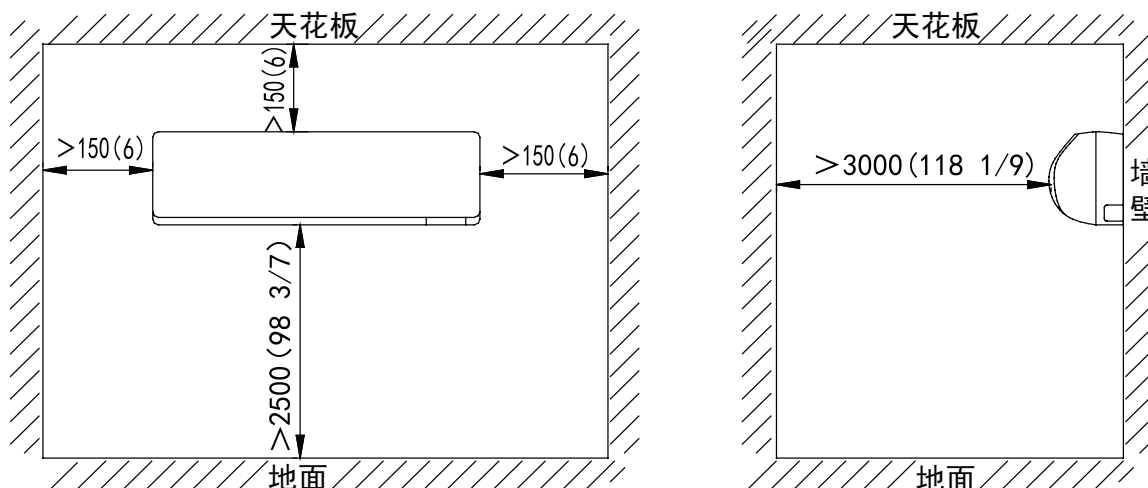

4.3.3 Installation notice

- (1) Installation dimension (refer to the outline dimension in the figure shown above)
- (2) Installation foundation
Make sure the top hanger has sufficient strength to withstand the weight of unit.
- (3) Installation site and environment
Keep the unit from insolation and rain;
Water can be drained from drainage pipe conveniently;
Keep the unit from fire, flammable objects, corrosive gap or exhaust gas;
There can't be any obstacle at air inlet and air outlet to in order to keep good ventilation;
Please reserve sufficient space for maintenance;
Please take proper measures to reduce noise and vibration.

4.3.4 Electrical installation of unit

- All electrical installation must be done by professionals according to national and local laws and regulations.
- The unit must be grounded reliably according to related requirements in GB 50169.
- Please connect wire according to the wiring diagram on the unit.

5 Installation of Electronic Expansion Valve Assy (unit with external EXV)

The EXV of indoor unit is built-in.



6 Installation of Refrigerant Pipeline

6.1 Allowable Length and Height Difference of Connection Pipe

Y type branch joint is adopted to connect indoor and outdoor units. Connecting method is shown in the figure below:

NOTICE! Equivalent length of one Y-type branch is 0.5m(1-5/8feet).

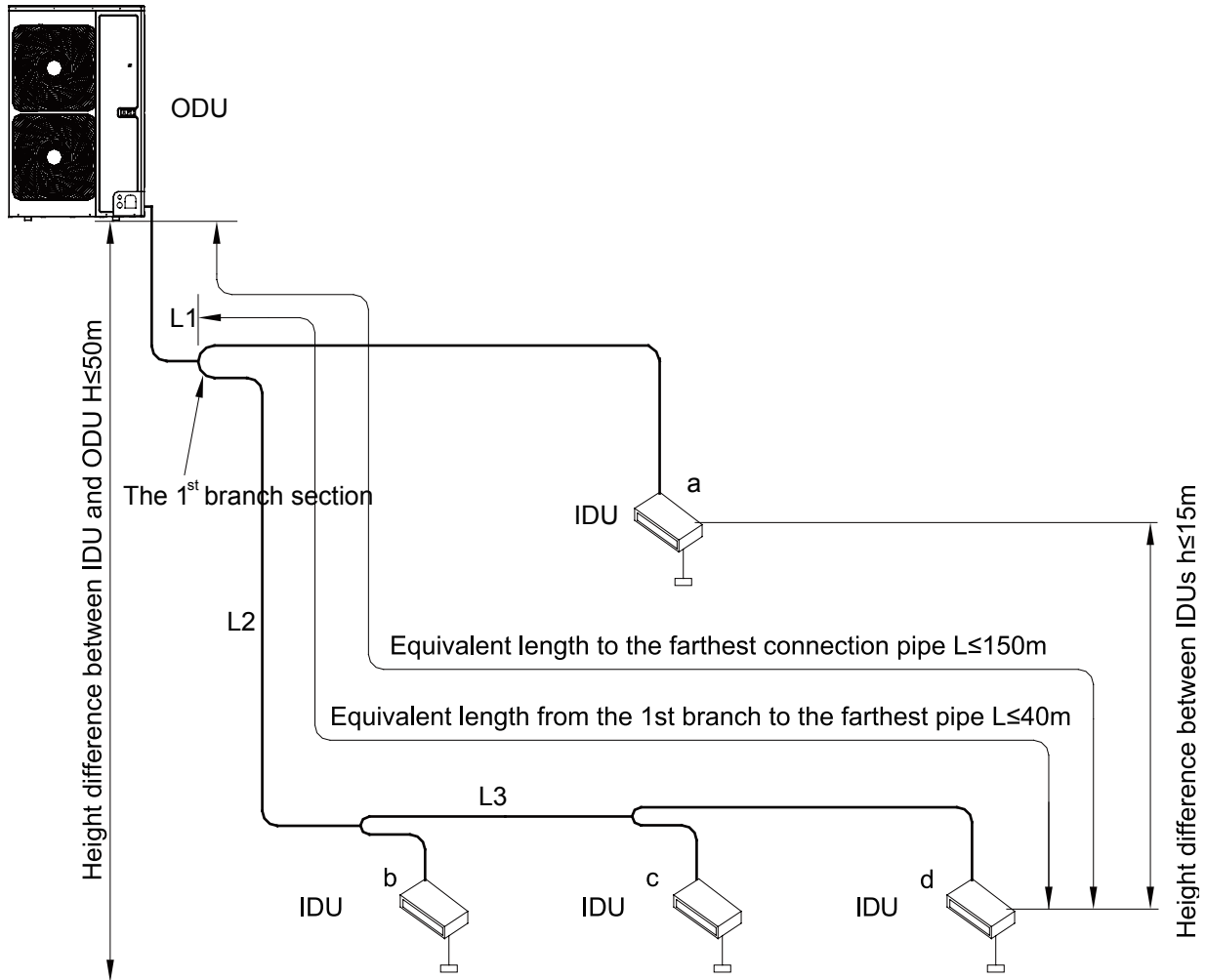

Each Y-type branch equals to 0.5m and each branch header equals to 1.0m.

Piping parameters of GMV-36WL/B-T(U) 、GMV-48WL/B-T(U):

		Allowable value(m/feet)	Fitting pipe
Total length (actual length) of fitting pipe		300(984)	$L1+L2+L3+a+b+c+d$
Length of farthest fitting pipe (m)	Actual length	120(394)	$L1+L2+L3+d$
	Equivalent length	150(492)	
From the 1 st branch to the farthest indoor pipe		40(131)	$L2+L3+d$
Height difference between ODU and IDU	ODU at upper side	50(164)	—
	ODU at lower side	40(131)	—
Height difference between IDUs		15(49)	—

6.2 Dimension of Pipe (Main Pipe) from ODU to the 1st Indoor Branch

Dimension of pipe from ODU to the 1st indoor branch will be determined by the dimension of outdoor connection pipe.

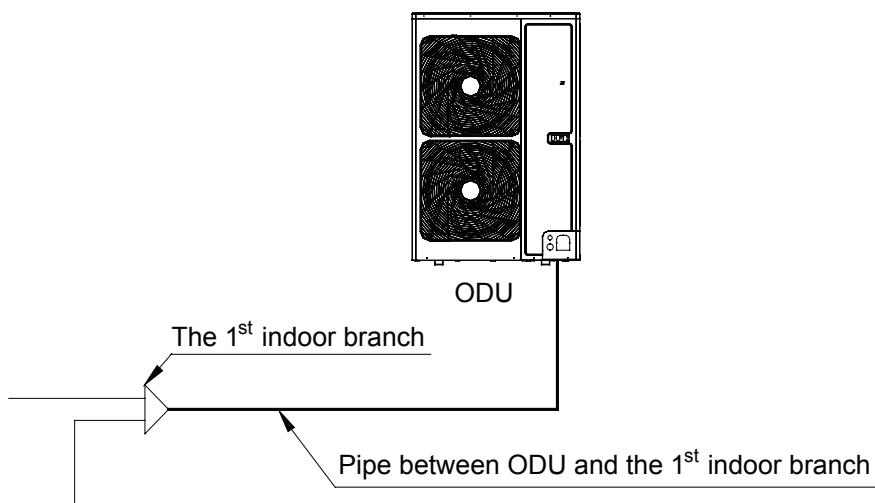

Dimension of outdoor connection pipe:

Basic module	Pipe dimension		Connection method
	Gas pipe (mm/inch)	Liquid pipe(mm/inch)	
GMV-36WL/B-T(U)	$\Phi 15.9(5/8)$	$\Phi 9.52(3/8)$	Flared joint
GMV-48WL/B-T(U)	$\Phi 15.9(5/8)$	$\Phi 9.52(3/8)$	

6.3 Selection of Indoor Branches

Select indoor branches according to the total capacity of downstream indoor units.

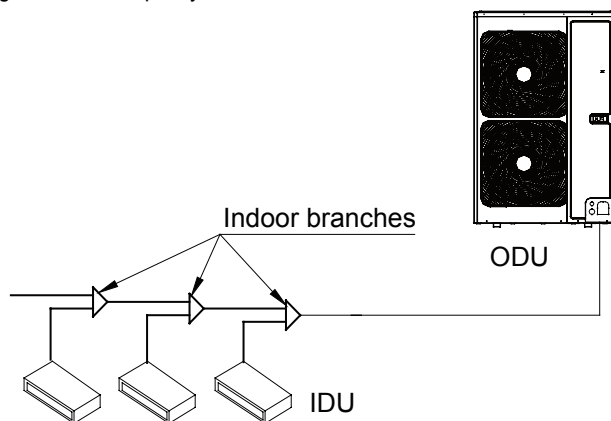

R410A Refrigerant system	Total capacity of downstream indoor units C (Btu/h)	Model
Y type branch	$C \leq 6800$	FQ01A

6.4 Dimension of Pipe between Indoor Branches

Select pipe between indoor branches according to the capacity of downstream indoor units; if the capacity exceeds that of the outdoor unit, capacity of outdoor unit prevails.

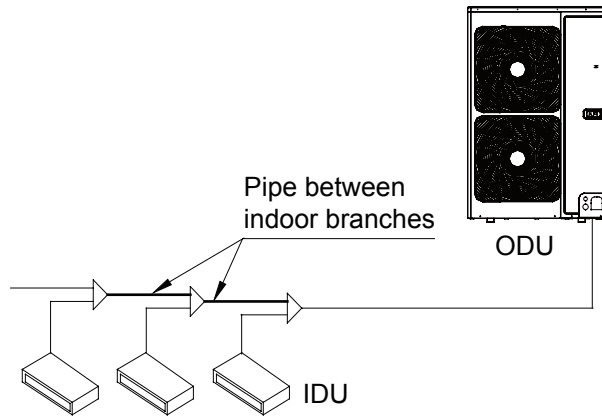

Total capacity of downstream indoor units C (Btu/h)	Gas pipe(mm/inch)	Liquid pipe(mm/inch)
$C \leq 19000$	$\Phi 12.7(1/2)$	$\Phi 6.35(1/4)$
$19000 < C \leq 48500$	$\Phi 15.9(5/8)$	$\Phi 9.52(3/8)$
$48500 < C \leq 75000$	$\Phi 19.05(3/4)$	$\Phi 9.52(3/8)$

6.5 Dimension of Pipe between Indoor Branch and IDU

Dimension of pipe between indoor branch and IDU should be consistent with the dimension of indoor pipe.

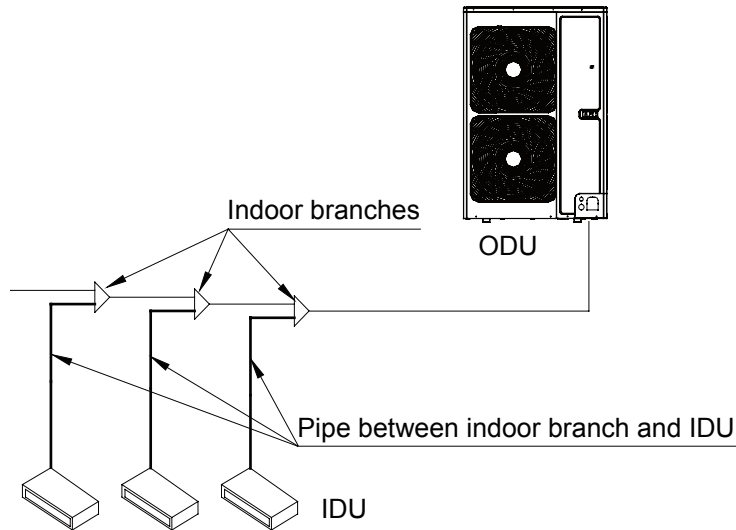

Rated capacity of IDU C (Btu/h)	Gas pipe(mm/inch)	Liquid pipe(mm/inch)
$C \leq 9600$	$\Phi 9.52(3/8)$	$\Phi 6.35(1/4)$
$9600 < C \leq 17000$	$\Phi 12.7(1/2)$	$\Phi 6.35(1/4)$
$17000 < C \leq 48000$	$\Phi 15.9(5/8)$	$\Phi 9.52(3/8)$
$48000 < C \leq 55000$	$\Phi 19.05(3/4)$	$\Phi 9.52(3/8)$
$55000 < C \leq 96000$	$\Phi 22.2(7/8)$	$\Phi 9.52(3/8)$

NOTICE! If the distance between IDU and its nearest branch is over 10m(33feet), then the liquid pipe of IDU (rated capacity ≤ 17000 Btu/h) shall be enlarged.

7 Installation of the Connection Pipe

⚠ CAUTION

- 1) Conform to the following principles during pipe connection: Connection pipe should be as short as possible, so is the height difference between indoor and outdoor units. Keep the number of bends as little as possible. Radius of curvature should be as large as possible.
- 2) Weld the connection pipe between indoor and outdoor units. Please strictly follow the requirements for welding process. Rosin joint or pin hole is not allowed.
- 3) When laying the pipe, be careful not to distort it. Radius of bending parts should be over 200mm(8inch). Note that pipes cannot be repeatedly bent or stretched; otherwise the material will get harder. Do not bend or stretch the pipe for more than 3 times at the same position.

7.1 Flaring Process

- 1) Use pipe cutter to cut the connection pipe in case it is unshaped.
- 2) Keep the pipe downward in case cutting scraps get into the pipe. Clear away the burrs after cutting.
- 3) Remove the flared nut connecting indoor connection pipe and outdoor unit. Then use flaring tool to fix the flared nut into the pipe.
- 4) Check if the flared part is flaring evenly and if there is any crack.

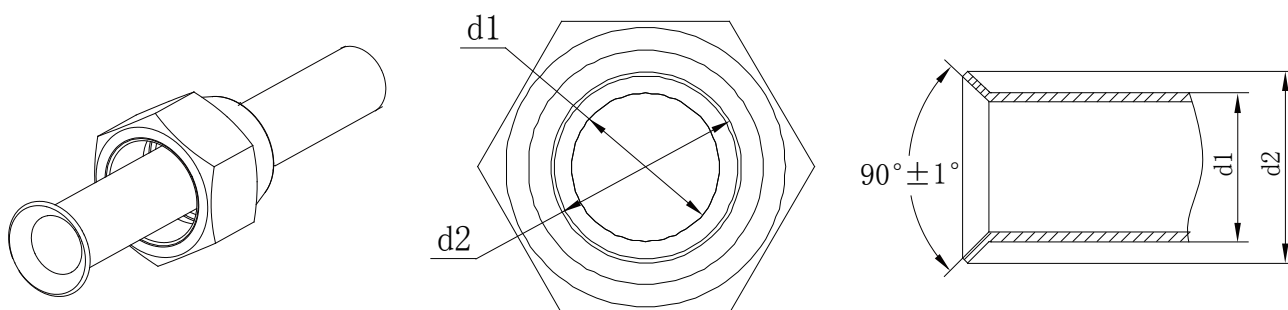

7.1.1 Pipe Bending

- 1) Reshape the pipe by hand. Be careful not to damage the pipe.

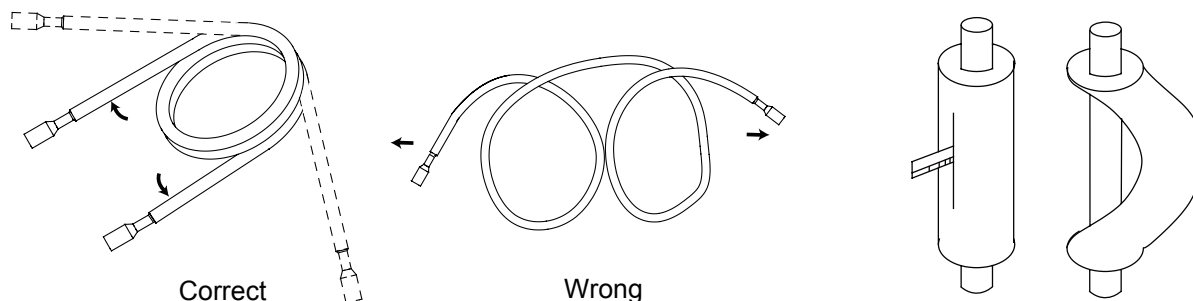

- 2) Do not bend the pipe over 90°.
- 3) If pipe is repeatedly bent or stretched, it will get hard and difficult to bend and stretch again. Therefore, do not bend or stretch the bend for over 3 times.
- 4) In case that direct bending will open cracks to the pipe, first use sharp cutter to cut the insulating layer, as shown in Fig.11. Do not bend the pipe until it is exposed. When bending is done, wrap the pipe with insulating layer and then secure it with adhesive tape.

7.1.2 Indoor Pipe Connection

- 1) Remove pipe cover and pipe plug.
- 2) Direct the flared part of copper pipe to the center of screwed joint. Twist on the flared nut tightly by hand, as in Fig.12. (Make sure indoor pipe is correctly connected. Improper location of the center will prevent flared nut from being securely twisted. Thread of nut will get damaged if the flared nut is twisted forcibly.)
- 3) Use torque wrench to twist on the flared nut tightly until the wrench gives out a click sound. (Hold the handle of wrench and make it at right angle to the pipe.

⚠ CAUTION

- 1) Use sponge to wrap the un-insulated connection pipe and joint. Then tie the sponge tightly with plastic tape.



2) Connection pipe should be supported by a bearer rather than the unit.

3) The bending angle of piping should not be too small; otherwise the piping might have cracks. Please use a pipe bender to bend the pipe.

4) When connecting IDU with connection pipe, do not pull the big and small joints of IDU with force in case the capillary tube or other tubes have cracks and cause leakage.

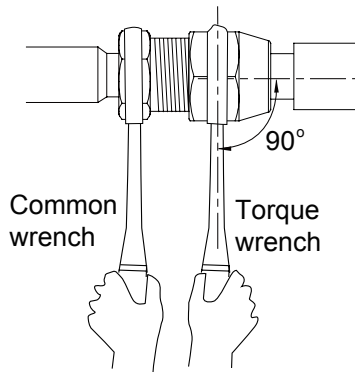
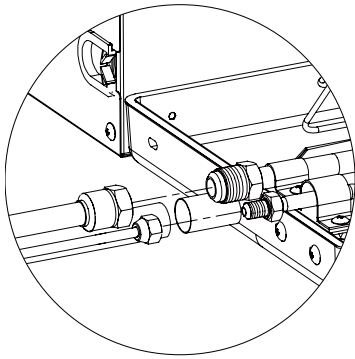

Pipe dimension	Tightening torque
6mm(1/4inch)	15-30N•m(11-22ft.-lb.)
9.5mm(3/8 inch)	35-40N•m(26-29ft.-lb.)
12.7mm(1/2 inch)	45-50N•m(33-37ft.-lb.)
16mm(5/8 inch)	60-65N•m(44-48ft.-lb.)

7.1.3 Outdoor Pipe Connection

Twist the flared nut on the connection pipe of outdoor valves. Twisting method is the same as for indoor pipe connection.

Below is the piping diagram of GMV-36WL/B-T(U), GMV-48WL/B-T(U). According to customer requirement or space limit, outlet pipe can be installed from the front, right or rear side.

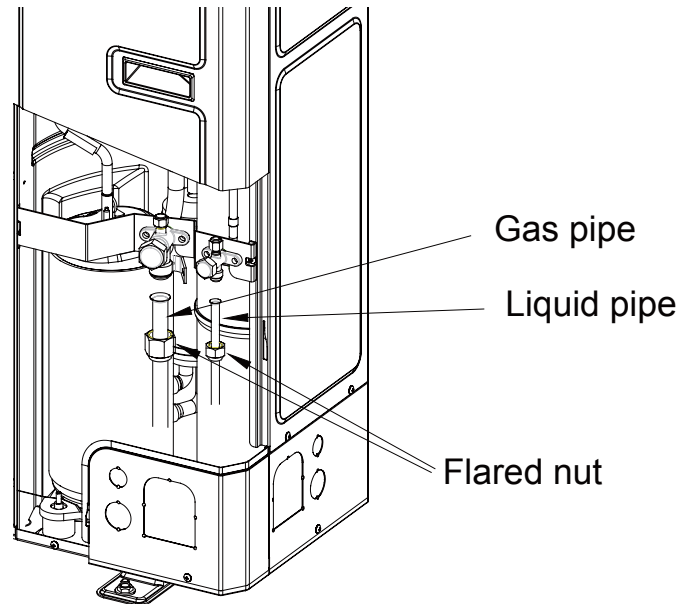

7.1.4 Installation of Y-type Branch

1) Y-type Branch

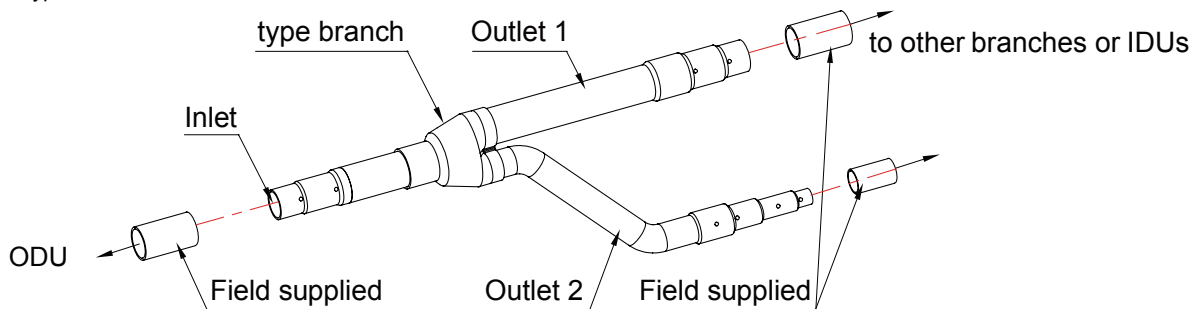

- 2) Y-type branch has several pipe sections with different dimension, which facilitates to match with various copper pipes. Use pipe cutter to cut in the middle of the pipe section that is of proper dimension and remove burrs as well.
- 3) Y-type branch must be installed vertically or horizontally.
- 4) Branch shall be isolated by insulating material that can bear 120° or even higher temperature. The attached foam of branch cannot be taken as insulating material.

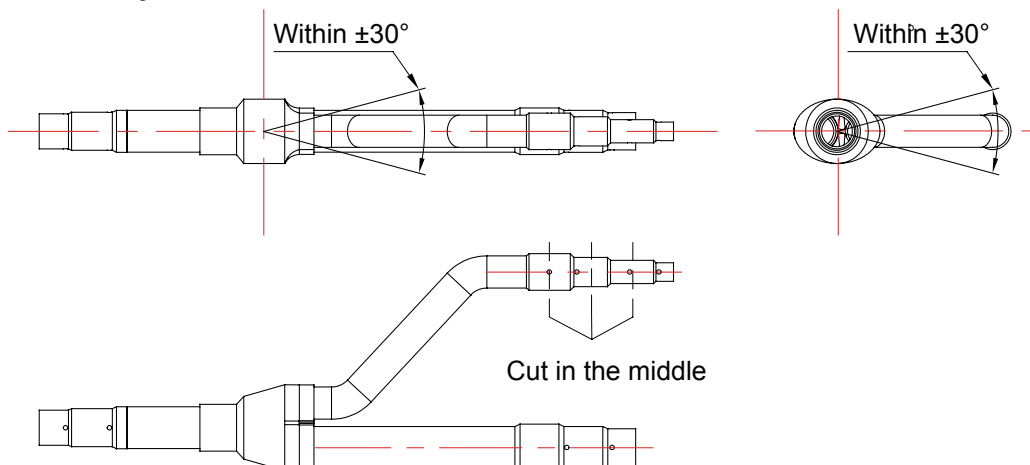

NOTICE! Branch shall be isolated by insulating material that can bear 120°C(248°F) or even higher temperature. The attached foam of branch cannot be taken as insulating material.

7.1.5 Thermal Insulation for Pipeline

- 1) For multi VRF system, every copper pipe should be labeled so as to avoid misconnection.
- 2) At the branch inlet, leave at least 500mm(19-3/4inch) straight pipe section.
- 3) Thermal insulation for pipeline.
 - ①. To avoid condensate or water leakage on the connection pipe, the gas pipe and liquid pipe must be wrapped with thermal insulating material and adhesive tape for insulation from the air.
 - ②. Thermal insulating material shall be able bear the pipe temperature. For heat pump unit, liquid pipe should bear 70°C or above and gas pipe should bear 120°C or above. For cooling only unit, both liquid pipe and gas pipe should bear 70°C or above.
Example: Polyethylene foam (bear 120°C or above); foaming polyethylene (bear 100°C or above).
 - ③. Joints of indoor and outdoor unit should be wrapped with insulating material and leave no gap between pipe and wall.

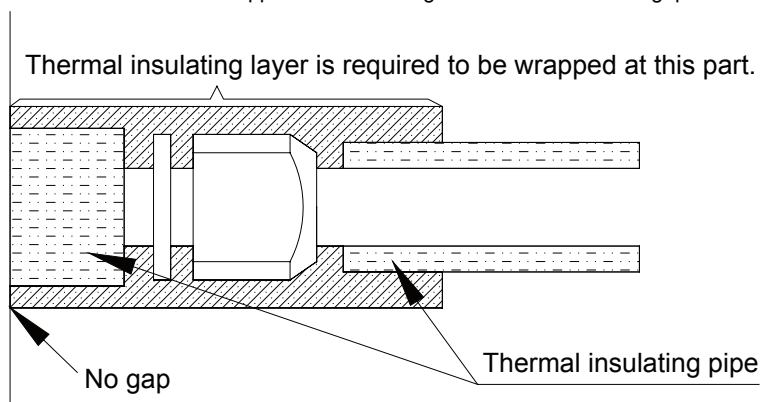

- ④. Thermal insulating material of branches should be the same as that of the pipeline. The attached foam of branches cannot be taken as insulating material.
- ⑤. When wrapping the tape, the later circle should cover half of the former one. Don't wrap the tape too tight, otherwise the insulation effect will be weakened.
- ⑥. After wrapping the pipe, apply sealing material to completely seal the hole on the wall.



NOTICE

- 1) Thermal insulating material shall be able bear the pipe temperature. For heat pump unit, liquid pipe should bear 70°C(158°F) or above and gas pipe should bear 120°C(248°F) or above. For cooling only unit, both liquid pipe and gas pipe should bear 70°C(158°F) or above.
- 2) Thermal insulating material of branches should be the same as that of the pipeline. The attached foam of branches cannot be taken as insulating material.

7.1.6 Support and Protection of Pipeline

CAUTION

- 1) Support should be made for hanging connection pipe. Distance between each support cannot be over 1m(3-1/4feet).
- 2) Protection against accidental damage should be made for outdoor pipeline. When pipeline exceeds 1m(3-1/4feet), a pinch board should be added for protection.

7.2 Disassembly of Compressor Feet

In order to prevent unit from damage during transportation, 2 metal pieces are fitted to outdoor unit's compressor feet before unit leaves factory.

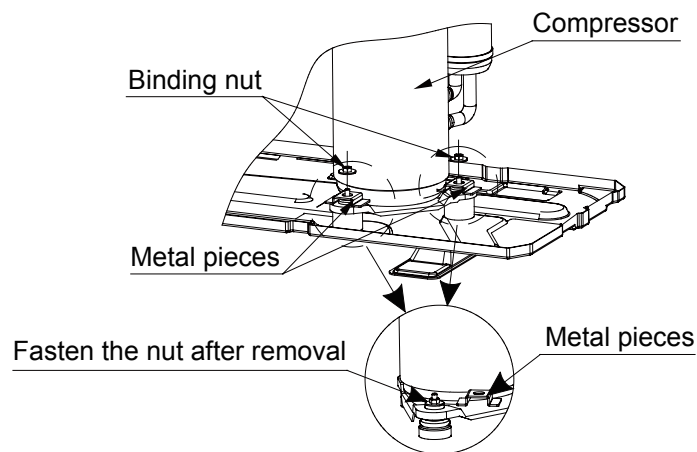

When installing the unit, metal pieces for transportation must be removed. Then fasten the binding nuts again and wrap back soundproofing cotton.

If unit runs with metal pieces fitting on, compressor will shake abnormally and unit's operating life will be shortened.

7.3 Vacuum Pumping, Refrigerant Adding

CAUTION

Do not purge the air with refrigerants but use a vacuum pump to vacuum the installation! There is no extra refrigerant in the outdoor unit for air purging!

7.3.1 Vacuum Pumping

- 1) Outdoor unit has been charged with refrigerant before delivery. Field-installed connection pipe needs to be charged with additional refrigerant.
- 2) Confirm whether outdoor liquid and gas valves are closed.
- 3) Use vacuum pump to withdraw the air inside indoor unit and connection pipe from the outdoor valve, as shown below.

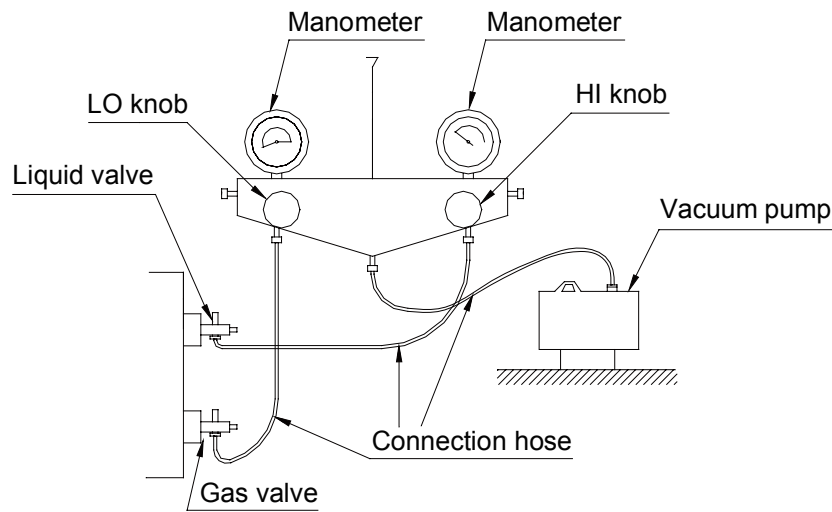

7.3.2 Refrigerant Adding

(1) Refrigerant quantity of outdoor unit before delivery:

Mode	GMV-36WL/B-T(U)	GMV-48WL/B-T(U)
Refrigerant Qty (kg/oz)	6.5(229)	6.5(229)

NOTICE

- 1) The refrigerant amount charged before delivery doesn't include the amount that needs to be added to indoor units and the connection pipeline.
- 2) Length of connection pipe is decided on site. Therefore the amount of additional refrigerant shall be decided on site according to the dimension and length of field-installed liquid pipe.
- 3) Record the amount of additional refrigerant for convenience of after-sales service.

(2) Calculation of the amount of additional refrigerant

Calculation method of the quantity of additional refrigerant (based on liquid pipe)

Quantity of additional refrigerant = \sum length of liquid pipe X quantity of additional refrigerant per meter(39-3/8inch)

Diameter of liquid pipe (mm/inch)	Φ22.2(7/8)	Φ19.05(3/4)	Φ15.9(5/8)	Φ12.7(1/2)	Φ9.52(3/8)	Φ6.35(1/4)
kg/m	0.35	0.25	0.17	0.11	0.054	0.022
oz/inch	0.314	0.224	0.152	0.099	0.048	0.020

NOTICE! Liquid pipe that is within 20m(65-5/8feet) doesn't need to be added with refrigerant.

First confirm that there is no leakage from the system. When compressor is not working, charge additional R410a with specific amount to the unit through the filling opening of the liquid pipe valve of the outdoor unit. If required amount cannot be quickly filled due to pressure increase of the pipe, then set the unit in cooling startup and fill refrigerant from the low pressure check valve of the outdoor unit.

3) Calculation example

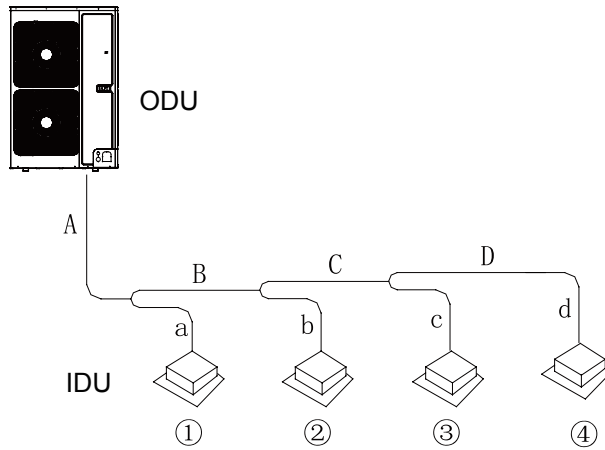

Indoor

No.	Indoor ①	Indoor ②	Indoor ③	Indoor ④
Model	Duct type GMV-ND18PLS/A-T(U)	Duct type GMV-ND12PLS/A-T(U)	Duct type GMV-ND09PLS/A-T(U)	Duct type GMV-ND09PLS/A-T(U)

Liquid pipe:

No.	A	B	C	D
Pipe size	Φ9.52mm(3/8inch)	Φ9.52 mm(3/8inch)	Φ9.52 mm(3/8inch)	Φ6.35 mm(1/4inch)
Length	10m(32-3/4feet)	5m(16-3/8feet)	5m(16-3/8feet)	5m(16-3/8feet)
No.	a	b	c	d
Pipe size	Φ9.52mm(3/8inch)	Φ6.35 mm(1/4inch)	Φ6.35 mm(1/4inch)	Φ6.35 mm(1/4inch)
Length	3m(9-3/4feet)	3m(9-3/4feet)	2m(6-5/8feet)	1m(3-1/4feet)

Total length of each liquid pipe

Φ9.52: $A+B+C+a=10+5+5+3=23\text{m}(75-1/2 \text{ feet})$

Φ6.35: $D+b+c+d=5+3+2+1=11\text{m}(36\text{feet})$

NOTICE! Liquid pipe that is within 20m(65-5/8feet) doesn't need to be added with refrigerant.

Therefore, the minimum quantity of additional refrigerant = $(23-20) \times 0.054 + 11 \times 0.022 = 0.404\text{kg}(14\text{oz})$.

8 Installation of Condensate Pipes

8.1 Ensure an inclination degree of more than 1% when connecting the drain pipe to the IDU.

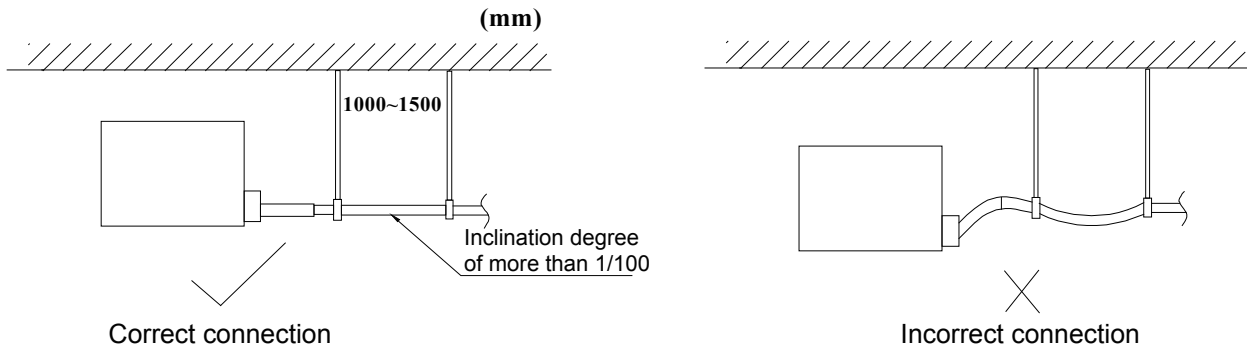

When connecting the drain pipe to that of the IDU, fix the pipes with the bands provided upon delivery instead of using the glue to facilitate further maintenance.

When connecting the drain pipe branches to the main pipe, lead through from the above part of the main pipe.

If the air volume of the IDUs is high and outdoor air resorption may be caused by negative suction pressure, provide a u-type drain trap at the water outlet side of each IDU, as shown in the following figure.

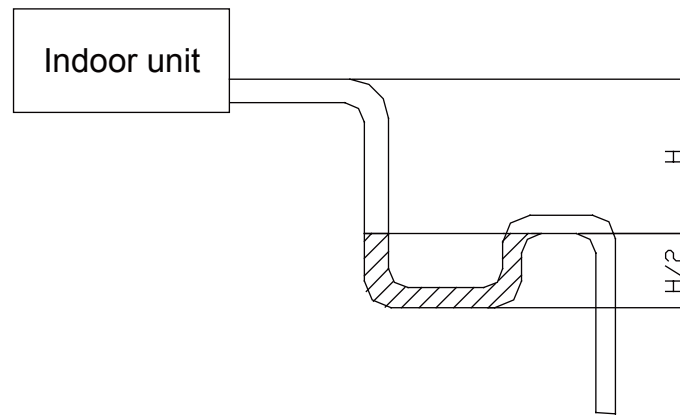

- ◆ Install drain trap connectors as shown in the following figure.
- ◆ Install a drain trap connector for each unit.
- ◆ The drain trap connector shall be installed in a way that facilitates trap cleaning.

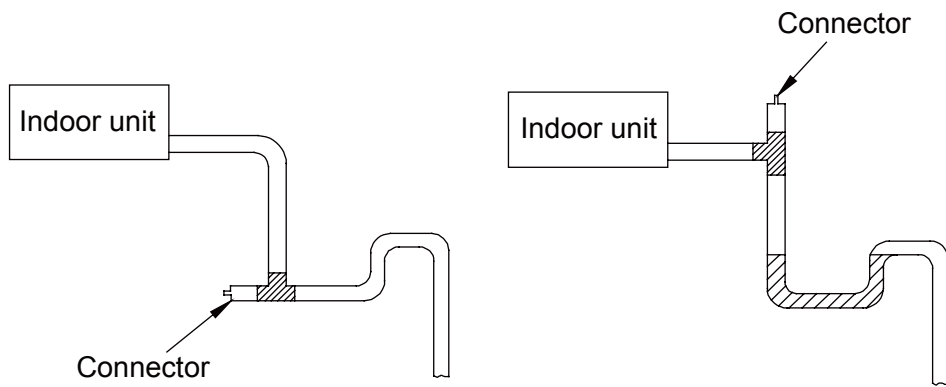

8.1.5 During condensate water pipe installation, ensure a distance above 500 mm between the pipe and the electric box of the unit for maintenance. In a case when the space is not enough, the final piping way must be determined by the technical personnel.

8.2. Requirements on Installation of Drain Pipes for Different Types of IDUs

8.2.1 Drain Pipe Installation for Hidden Air-duct-type IDU for Air Supply

- a. Ensure an inclination degree of greater than 1% when connecting the drain pipe to the IDU.
- b. When connecting the drain pipe to that of the IDU, fix the pipes with the bands instead of using the glue to facilitate further maintenance.
- c. There is a condensate water outlet on both sides of the IDU. After one condensate water outlet is determined, use the rubber stopper to block the other outlet. Tie it with threads and strap with insulation materials to prevent leakage.
- d. The connection between the drain pipe and that of the IDU is shown in the following figure.

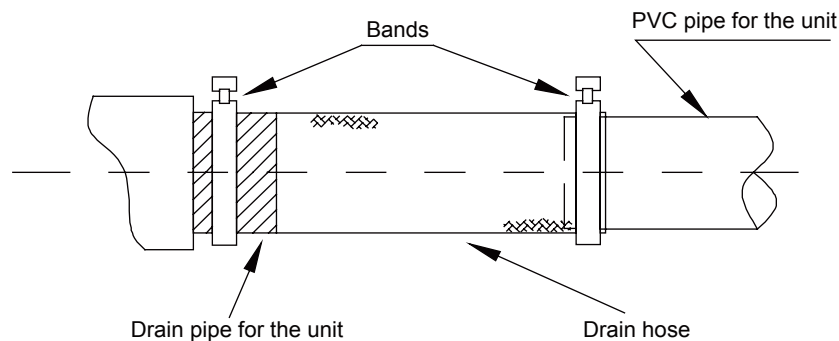

- e. Apply insulation materials to the condensate water pipe joints to prevent dewing. d. Insulation for connection between the drain pipe and that of the IDU is shown in the following figure.

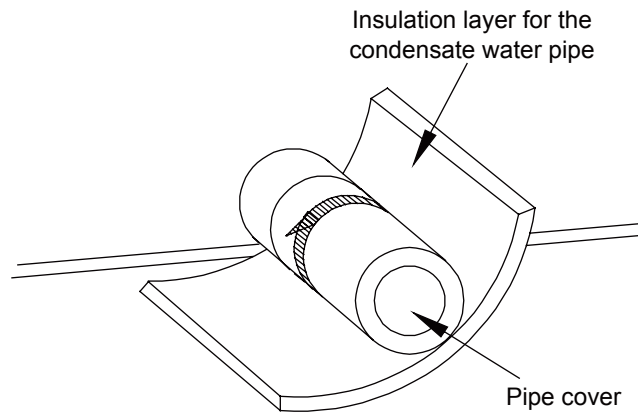

8.2.2 Drain Pipe Installation for IDU

- a. Use pipe clips instead of applying glue to connect the hoses provided upon delivery and plastic pipes on the device. Connect the other end of the joint to the elbow. The height from the suction inlet of the discharge pump is about 200 to 500 mm. Ensure a proper inclination degree while connecting to the main drain pipe.
- b. The lifting pipe for drainage must be provided as shown in the following figure.

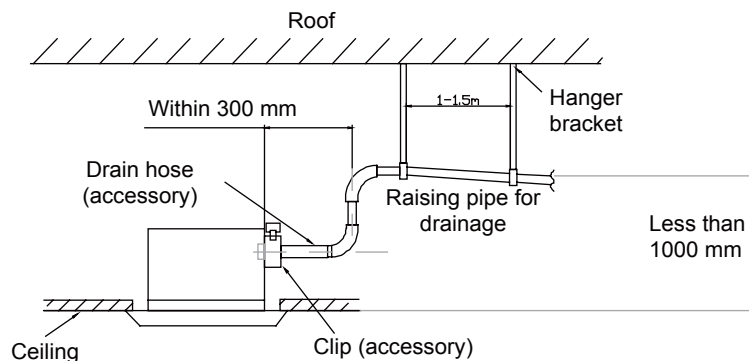

- c. The drain pump shall be fixed securely. Otherwise, abnormal noises will be generated.

8.3. Requirements on Independent Drainage for Each IDU

Requirements on independent drainage design for each IDU are as follows:

- a. There must be a proper inclination for the drain pipe.
- b. The drain pipe must be installed to facilitate drainage to the largest extent and be as short as possible.
- c. If the water is discharged to the outdoor side, it cannot drop to the outdoor ground directly.

8.4. Requirements on Centralized Drainage for IDUs

- a. When there are multiple IDUs in the same building, centralized drainage is adopted.
- b. When a header pipe is used, the drain pipe of each IDU must be higher than the header pipe.
- c. The diameter of the header pipe must be determined on the number and capacity of IDUs.
- d. When installing pipe, start from the highest point of the pipe and follow the specified inclination to smoothly discharge condensate water.
- e. Connect branches to the main pipe from the upper part or side instead of lower part of the main pipe.
- f. Insulate all condensate water pipes, especially for joints at elbows.

9 Electric Wiring

⚠ WARNING

- 1) All electrical installation must be performed by qualified technicians in accordance with local laws, regulations and this user manual.
- 2) Use air conditioner specialized power supply and make sure that it is consistent with system's rated voltage.
- 3) Do not pull the power cord with force.
- 4) Caliber of the power cord must be large enough. A damaged power cord or connection wire must be replaced by specialized electrical cords.

- 5) Connect the unit to specialized grounding device and make sure it is securely grounded. It's a must to install air switch and current circuit breaker that can cut off the power of the entire system. The air switch should include magnetic trip function and thermal trip function so that system can be protected from short circuit and overload.
- 6) Air conditioner belongs to class I electrical appliance, so it must be securely grounded.
- 7) The yellow-green wire inside the unit is a ground wire. Do not cut it off or secure it with tapping screws, otherwise it will lead to electric shock.
- 8) Power supply must include secure grounding terminal. Do not connect the ground wire to the following: Water pipe; Gas pipe; Drain pipe; Other places that are deemed as not secure by professional technicians.

9.1 Wiring Diagram

1) Connection of power cord and communication wire

Separate power supply for Indoor and Outdoor

NOTICE! The remote monitor can be installed when it is necessary. The wire (match with resistance) must be connected with ODU (see a and b) only the remote monitor is installed.

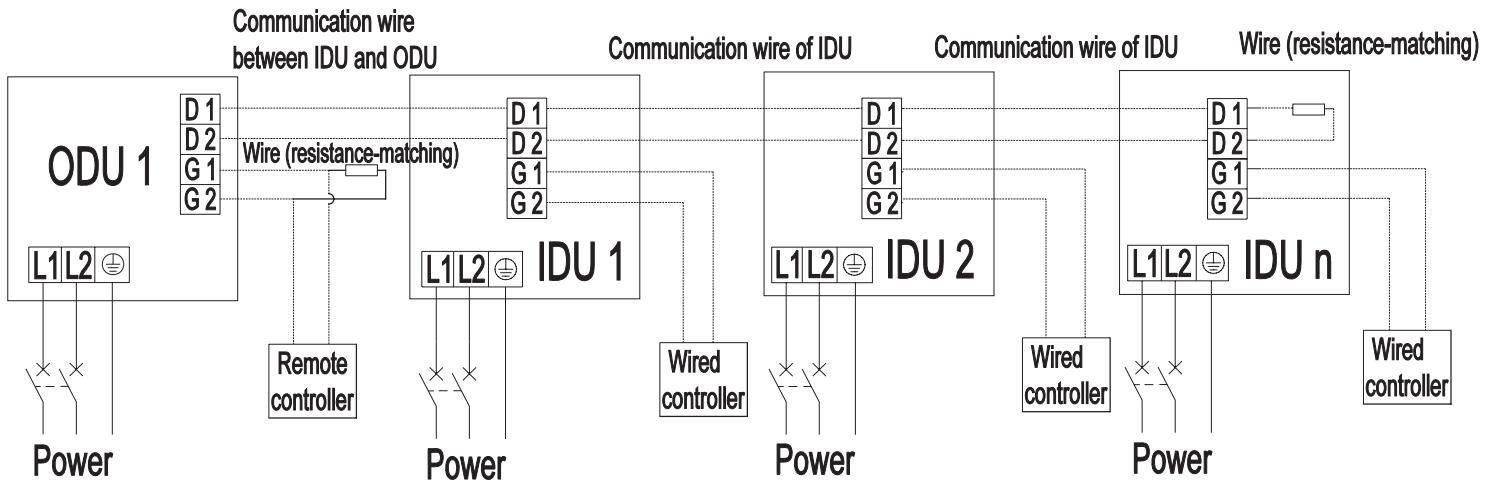

a Connection of power cord and communication wire for IDU and one ODU

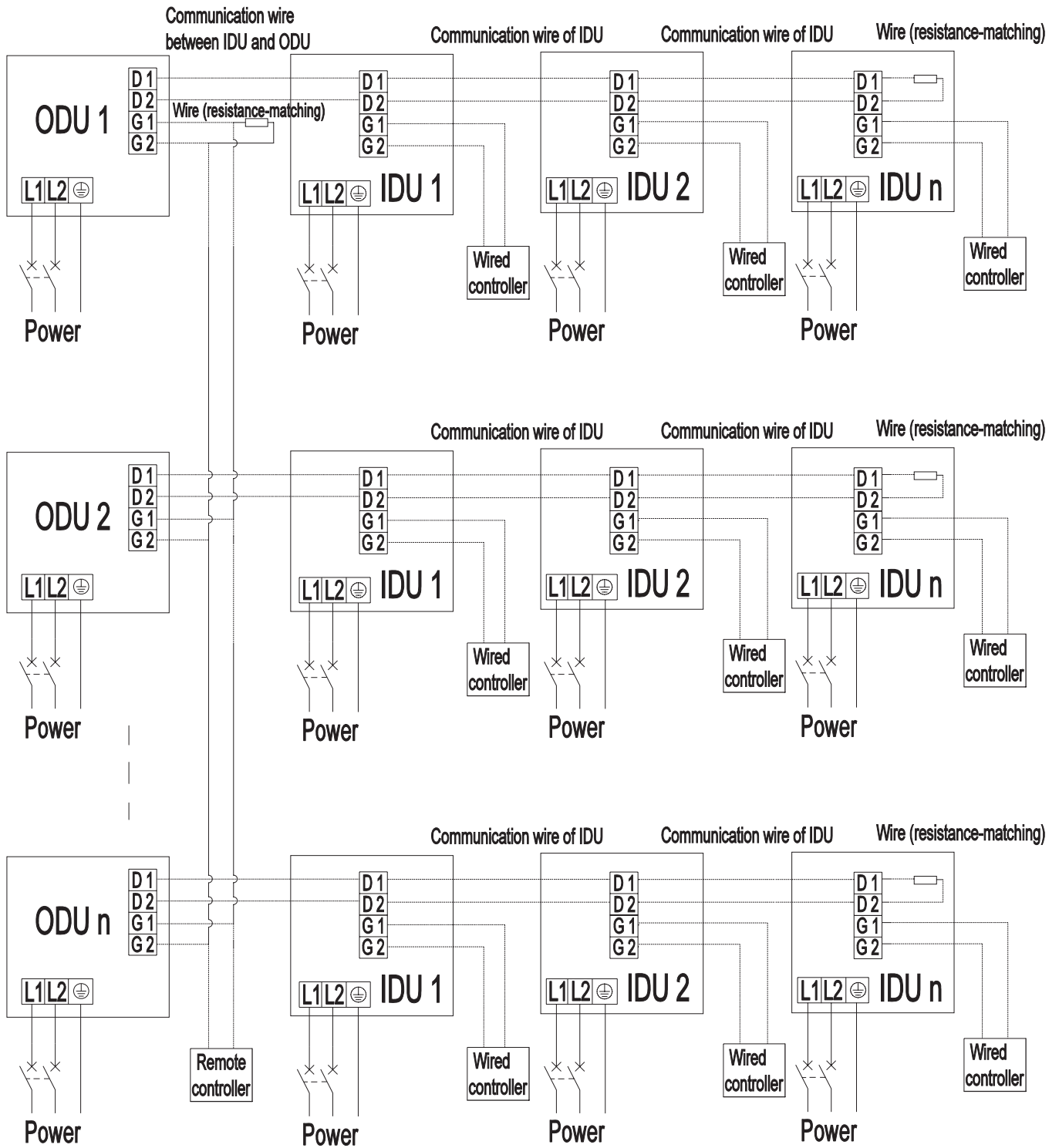

b Connection of power cord and communication wire for IDU and multi ODUs

NOTICE! : ODU n(Max)=16. The wire (match with resistance) must be connected with the last ODU.

2) The wiring diagram for power cord of outdoor unit and communication wire.

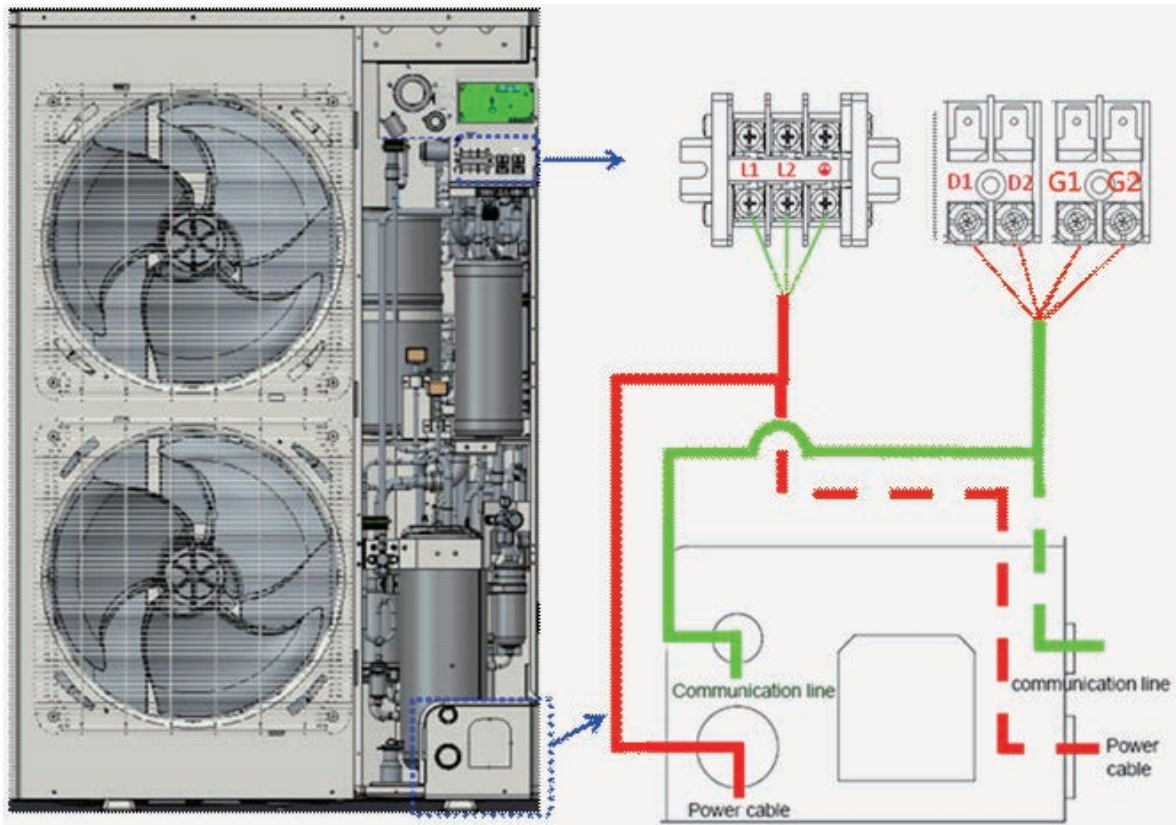

Wiring of the Power Cord

- (1) Open the side plate.
- (2) Connect the power cord to the terminals “L1”, “L2” and also the earthing screw, and then connect the communication line “D1,D2” of the indoor unit to those of the outdoor unit correspondingly. The communication line “G1, G2” could be used to connect the remote monitor. Please use the bonding screw to connect the earthing cord. The location is showing in the [Fig.](#)
- (3) Fix the power cord and communication line with wire clips.
- (4) Let the power cord and communication line go through the rubber ring.



9.2 Power Cable Wire Gauge and Circuit Breaker Selection

9.2.1 Outdoor

Model	Power supply	Max Fuse Size/ Fusible Max. (A)	Max Ckt, Bkr Size/ Disjoncteur Max.(A)	Min. Circuit Ampacity
GMV-36WL/B-T(U)	208/230V~ 60Hz	50	50	45
GMV-48WL/B-T(U)	208/230V~ 60Hz	50	50	45

9.2.2 Indoor

(1) Low Static Pressure Duct Type Indoor Unit

Model	GMV-ND07PLS/ A-T(U)	GMV-ND09PLS/ A-T(U)	GMV-ND12PLS/ A-T(U)	GMV-ND14PLS/ A-T(U)	GMV-ND18PLS/ A-T(U)	GMV-ND22PLS/ A-T(U)
MCA A	0.25	0.25	0.25	0.38	0.63	0.63
MOP A	0.45	0.45	0.45	0.68	1.13	1.13

(2) 4-way Cassette Indoor Unit

Model	GMV-ND07T/A-T(U)	GMV-ND09T/A-T(U)	GMV-ND12T/A-T(U)	GMV-ND15T/A-T(U)	GMV-ND18T/A-T(U)
MCA	0.25	0.31	0.31	0.31	0.31
MOP	0.45	0.56	0.56	0.56	0.56

Model	GMV-ND24T/A-T(U)	GMV-ND30T/A-T(U)	GMV-ND36T/A-T(U)	GMV-ND42T/A-T(U)	GMV-ND48T/A-T(U)
MCA	0.31	0.44	0.44	0.44	0.44
MOP	0.56	0.79	0.79	0.79	0.79

(3) Wall Mounted type Indoor Unit

Model	GMV-N07G/A3A- D(U)	GMV-N09G/A3A- D(U)	GMV-N12G/A3A- D(U)	GMV-N18G/A3A- D(U)	GMV-N24G/A3A- D(U)
MCA A	0.25	0.25	0.2625	0.2625	0.3875
MOP A	0.45	0.45	0.4725	0.4725	0.6975

10 Debugging of Unit

⚠Caution:

- ①. After the initial installation is finished and the main board of outdoor unit is replaced, it must perform debugging. Otherwise, the unit can't operate.
- ②. The debugging must be performed by professional person or under the the guide of professional person.

10.1 Preparation for debugging

- (4) Do not disconnect the power before the installation is finished,
- (5) All wires for controller and electric wires must be connected correctly and reliably.
- (6) Check the the fixing ring of the foot of compressor for transportaion is removed.
- (7) Remove all sundries from the unit, such as metal chips, joint, forceps holder, and so on.
- (8) Check whether the appearance and pipeline system are damaged during carry or transportation process.
- (9) Calculate the required added refrigerant-charging volume according to the length of pipe of system and pre-charge the refrigerant. If refrigerant can't be added any more when the required refrigerant-charging volume hasn't been reached, record to refrigerant volume which still needs to be added and continue to add refrigerant during run test operation process. Please refer to below run test for the refrigerant-adding stage during run test process.
- (10) After adding refrigerant, please make sure the valve for outdoor is opened completely.
- (11) For the convenient of troubleshooting, the unit can't be connected to the PC which installed with related debugging software and make sure that the the datas in real time of this unit can be inspected by this computer. Please refer to Service Manual for the installation and connection of the bebugging software.
- (12) Before turn test, please do make sure that the preheat time for compressor is 8h above and touch the compressor to see whether preheat is normal. You can perform run test only after normal preheat. Otherwise, it may damage the compressor.

10.2 Trial run

10.2.1 Notice

- (1) Before the trial running, make sure the unit is power on and compressor has been preheated for more than six hours. Touch the unit to check whether it's normally prehetated. Start test operation after unit is normally preheated, otherwise compressor might be damaged.
- (2) Before the test running, make sure the needed amount of refrigerant has been added to the pipe or at least 70% of the needed refrigerant has been added.
- (3) During the test running, system will operate according to the ambient temperature.
 - 1) When outdoor temperature is above 20℃, debugging shall be in cooling mode.
 - 2) When outdoor temperature is below 20℃, debugging shall be in heating mode.

- (4) The test run should be carried out by the professionally skilled personnel on the premise that all items listed above are in normal conditions.
- (5) Let the unit energized and switch the wired controller or the remoter controller to "ON".
- (6) The fan motor and compressor of the outdoor unit will run automatically in three minutes.
- (7) If there is some unusual so started, turn off the unit for an immediate check.

10.2.2 Check after Installation

Please check the following items before test operation.

Items to be checked	Possible malfunction
Has it been fixed reliable?	The unit may drop, vibrate or make noise.
Has the gas leakage been checked?	It may cause insufficient cooling(heating) capacity.
Is the thermal insulation of the unit sufficient?	It may cause condensation and dripping.
Is the drainage well?	It may cause condensation and dripping.
Is the voltage in accordance with the rated voltage marked on the nameplate?	It may cause electric malfunction or the components may be burned out
Are the lines and pipelines correctly installed?	It may cause electric malfunction or the components may be burned out
Has the unit been safely grounded?	It may cause electrical leakage.
Are the models of lines in conformity with requirements?	It may cause electric malfunction or the components may be burned out
Are there any obstacles near the air inlet and outlet of the indoor and outdoor units?	It may cause insufficient cooling(heating) capacity.
Have the length of connection pipes and refrigerant charge amount been recorded?	It is not easy to decide the charge amount of refrigerant.

1) Before test operation

- ◆ The appearance of the unit and the refrigerant pipes cannot be damaged during the installation.
- ◆ Do not switch on power before installation is finished completely.
- ◆ Electrical wiring must be connected correctly and securely.
- ◆ The stop valves of the outdoor unit should be opened fully.
- ◆ All the impurities such as scraps and thrums must be cleared from the unit.

2) Test operation method

- ① The test operation should be carried out by the professionally skilled personnel on the premise that all items listed above are in normal conditions.
- ② Set the status of the power supply switch as "ON" six hours before the start of operation
- ③ Press mode button, to select the COOL, or HEAT. Whether the air conditioner is work normally or not.
- ④ Make sure that every combination of indoor units can work well.

Caution!

If the unit cannot work nor has any abnormal noise after the compressor is started, turn off the unit for an immediate check.

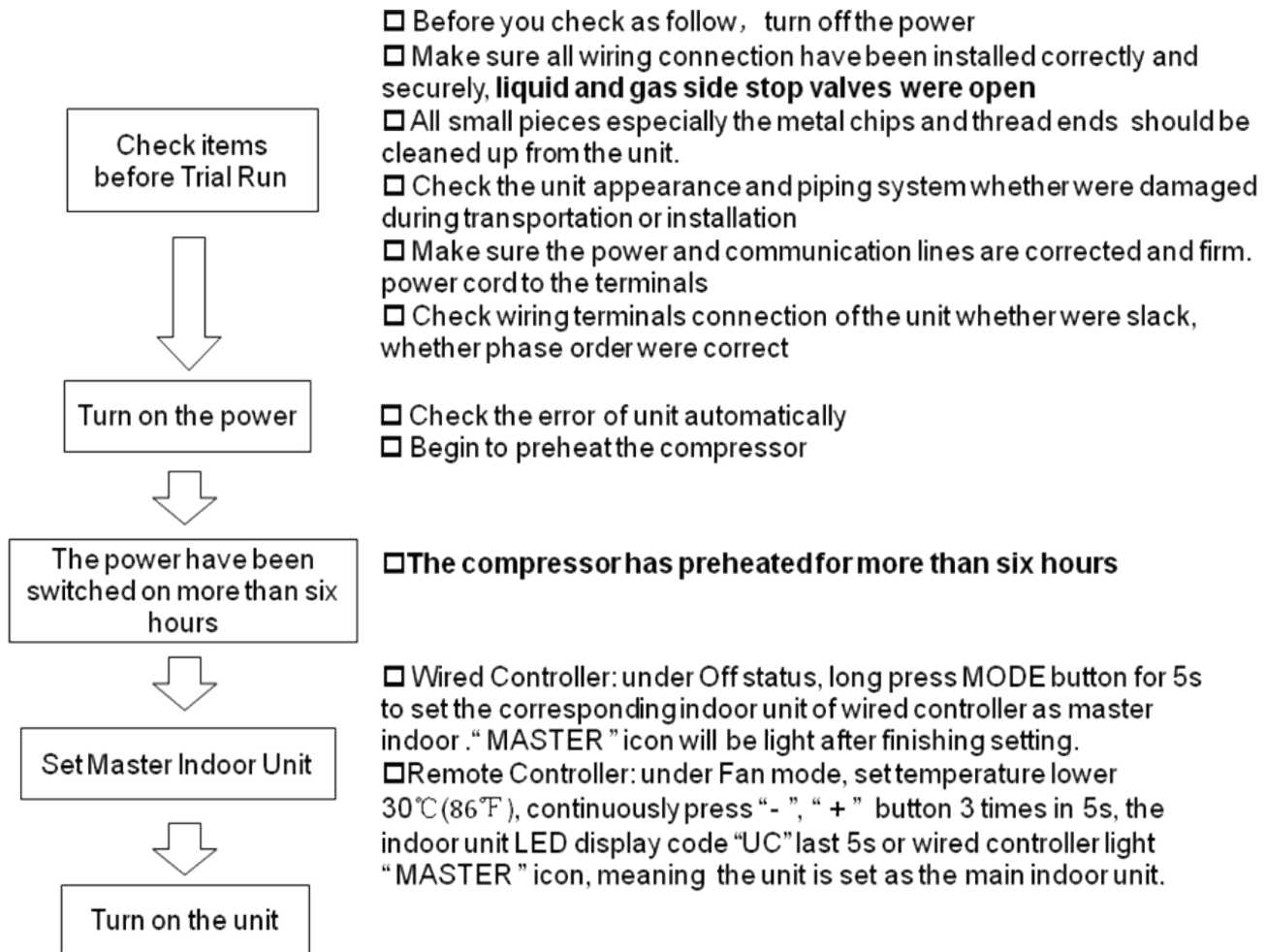

10.3 Testing Board Introduction

10.3.1 Compose of Testing Board

The testing board is in front of electrical box and can be observed well. It has several following advantages: detect indoor unit numbers and indoor unit address, displays real running function and error code automatically. It is composed of the function section, data section, button section and DIP section.

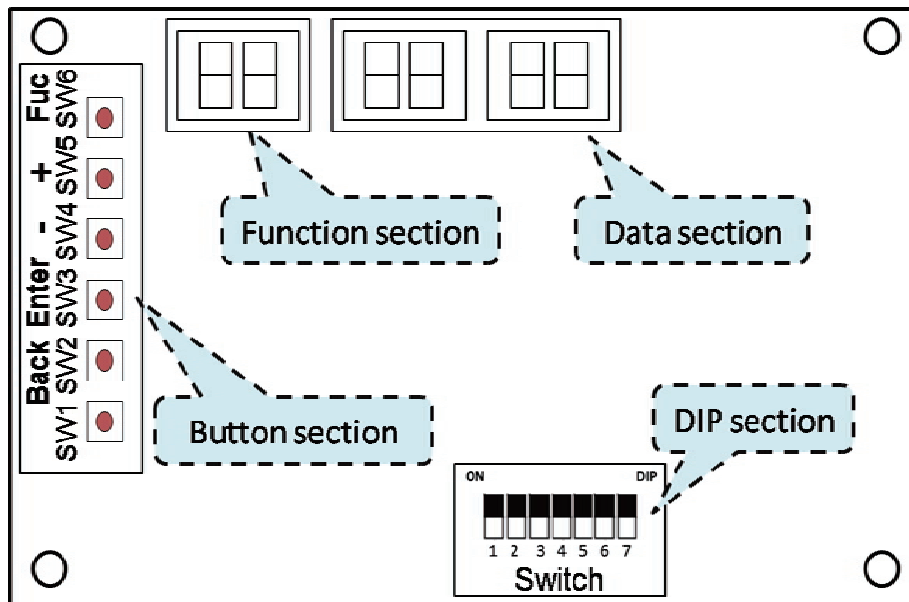

Running state	The display of function section	The display of data section																
Stop	<p>① The section will display the numbers of the indoor units which have established communication with the outdoor unit. For example, if there are twenty established indoor units, the section will display “20”.</p> <p>② It will display the address of the indoor units by turns. For example, the “44” is represented of the indoor unit’s IP.</p>	<p>① If the function section displays the numbers of the indoor units, the data section will display the outside temperature. For example, the “35” is represented of 35°C.</p> <p>② If the function section displays the address of the indoor unit, the data section will display the model of the indoor unit, for example, the “56” is represented of 56 model.</p>																
Normal	<p>The code of running state:</p> <table border="1"> <thead> <tr> <th>Code</th> <th>Running state</th> <th>Code</th> <th>Running state</th> </tr> </thead> <tbody> <tr> <td>UE</td> <td>Pressure equalization</td> <td>UH</td> <td>Heating</td> </tr> <tr> <td>UP</td> <td>Pump down</td> <td>A4</td> <td>Oil returning</td> </tr> <tr> <td>UC</td> <td>Cooling</td> <td>A3</td> <td>Defrosting</td> </tr> </tbody> </table>	Code	Running state	Code	Running state	UE	Pressure equalization	UH	Heating	UP	Pump down	A4	Oil returning	UC	Cooling	A3	Defrosting	<p>It displays the target gear of the compressor. If the gear is zero, it will display “0”. For example, the gear is the fifteenth; it will display “15”. The range of the gear is from 0 to 60.</p>
Code	Running state	Code	Running state															
UE	Pressure equalization	UH	Heating															
UP	Pump down	A4	Oil returning															
UC	Cooling	A3	Defrosting															
Malfunction	<p>If the malfunction occurs in the system, the section will display the error code. If there are several malfunctions, it will display the error codes by turns at intervals of 2 seconds.</p>	<p>① If the malfunction occurs in the outdoor unit, the section displays nothing;</p> <p>② If the malfunction occurs in the indoor units, the section displays the address of the indoor unit.</p>																

10.3.2 Button section

Key	Fuc	+	–	Enter	Back	SW1
Signification	Function	Increase	Decrease	Enter	Back	/

- ① When entering the menu to set parameters, the function section will flash running codes and the data section will flash the current parameters.
- ② When the menu is set, the data section will flash “=”. After the “=” stops blinking, the unit will run the new parameters.

10.3.3 The flow chart of operation

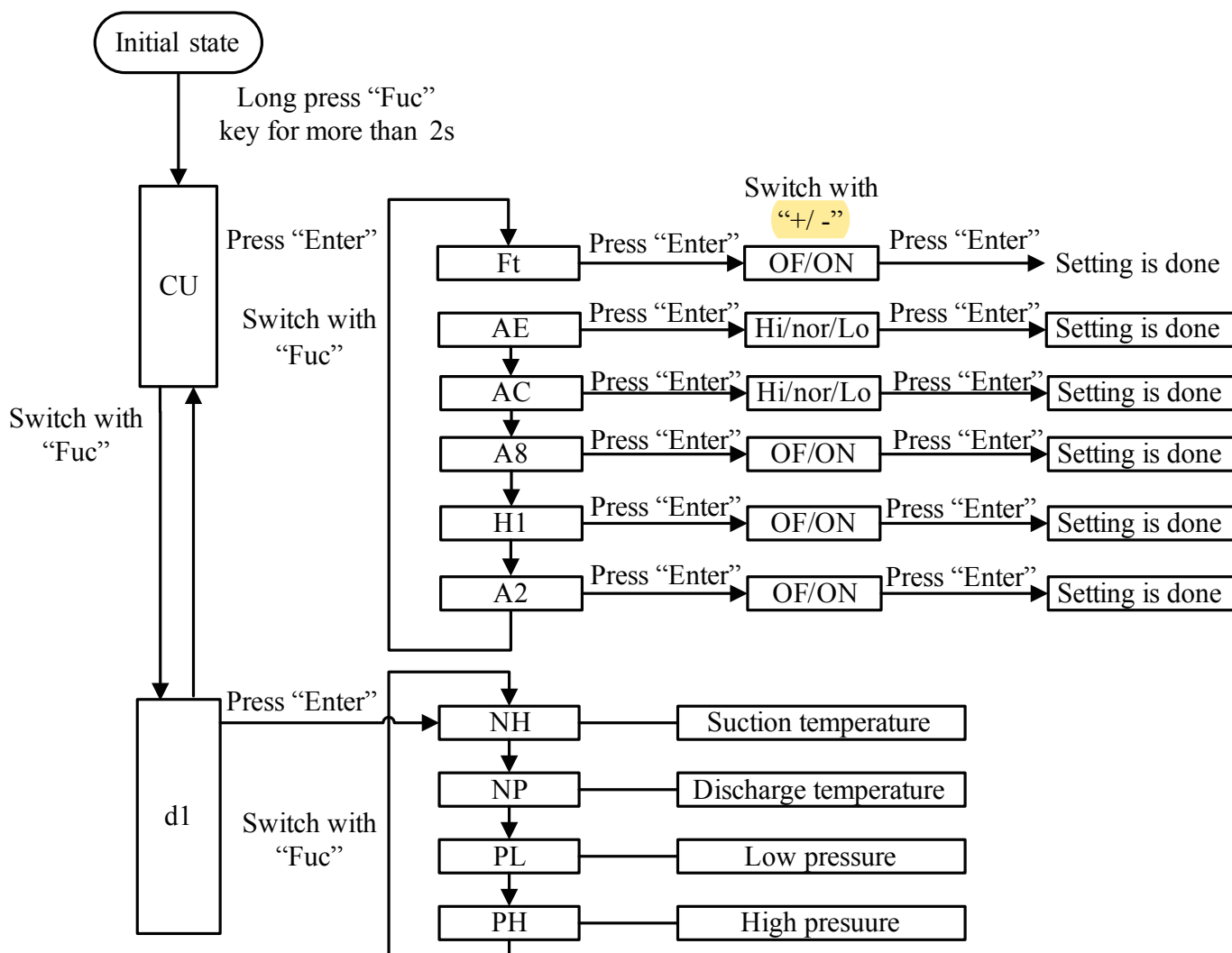

Note:

- ① Long press “Fuc” key for more than 2s to enter the first-level menu. The first-level menu includes control unit, display unit 1 and display unit 2.
- ◆ Press “Enter” key to enter the second-level menu.
- ◆ Press “Fuc” key to switch the menu.
- ◆ Press “Back” key to the previous menu.
- ② Control unit (CU) operation:

◆ **When entering into the control unit:**

The function section flashes the running code and the data section display the current parameter uninterrupted.

◆ **Set parameters:**

Press “Enter” key to enter the second-level menu, and set parameters with the “+” “-” keys. Now the function section displays the running code uninterrupted and the data section flashes the set parameters.

◆ **Finish setting:**

After press “Enter” key to the end, the function section will display the running code uninterrupted and the data section display the set parameters uninterrupted.

◆ **Back:**

Press “Back” key to the previous menu, and long press the “Back” key to exit the operation.

① Display unit 1 (d1) operation:

◆ **When entering into the display unit 1:**

The function section display running code uninterrupted and the data section display the current value uninterrupted.

◆ “+” “-” **Keys are invalid in the operation.**

② If no operation is performed within 1min, it will automatically return to the normal display.

◆ The code of data section

Set evaporation temperature	H(represent High)	N(represent Normal)	L(represent Low)
Set condensation temperature			
Vacuum operation	OF(represent OFF)	ON	/
Set defrosting mode	OF(represent OFF)	ON	/
Set defrosting mode	OF(represent OFF)	ON	/

For example: **How to Display low pressure**

- ① Long press “Fuc” key for more than 2s to enter the first-level menu: the function section flashes “CU” code and the data section is blank.
- ② Switch with the “Fuc” key again: the function section flashes “d1” code and the data section is blank.
- ③ Press “Enter” key to enter the second-level menu: the function section flashes “NH” code and the data section display the current suction temperature.
- ④ Switch with the “Fuc” key to display low pressure: the function section flashes “PL” code and the data section display the current low

DIP section

The centralized control address DIP switch indicates the centralized control address required when different refrigerating systems are controlled in a centralized manner. The default factory setting is "0000000".

If it is not required to use centralized control between multiple refrigerating systems, this DIP switch can retain the factory settings without being changed.

If it is required to use centralized control between multiple refrigerating systems, set the DIP switch must be set as follows:

DIP1	DIP2	DIP3	DIP4	DIP5	DIP6	DIP7	Address No.
0	0	0	0	x	x	x	0
1	0	0	0	x	x	x	1
0	1	0	0	x	x	x	2
1	1	0	0	x	x	x	3
0	0	1	0	x	x	x	4
1	0	1	0	x	x	x	5
0	1	1	0	x	x	x	6
1	1	1	0	x	x	x	7
0	0	0	1	x	x	x	8
1	0	0	1	x	x	x	9
0	1	0	1	x	x	x	10
1	1	0	1	x	x	x	11
0	0	1	1	x	x	x	12
1	0	1	1	x	x	x	13
0	1	1	1	x	x	x	14
1	1	1	1	x	x	x	15

For example, Address No.4 of ODU setting as:

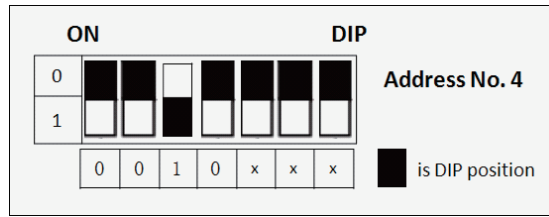

Defines and differentiates addresses of different systems in the case of centralized control by multiple systems. The address DIP switch is used only when centralized control is required. Otherwise, the factory settings are used without being changed.

CAUTION: Function DIP switch must be set when the ODU is powered off, and then the settings are valid after the ODU is powered on.

The meaning of running code:

Sorts	Function section	Data section	Remarks
Control Unit	CU	Blank	
Set evaporation temperature	AE	Default:N	Use the “+” “-” keys to switch L, N and H. If you want to get a higher cooling capacity, select L; else select H.
Set condensation temperature	AC	Default:N	Use the “+” “-” keys to switch L, N and H. If you want to get a higher heating capacity, select H; else select L.
Quickly check	Ft	The current parameter	Use the “+” “-” keys to switch ON, OF. ON represents that the unit is running the current state. OF represents that the unit is not running the current state.
Vacuum operation	A8	The current parameter	
Set defrosting mode	H1	The current parameter	
Set refrigerant recovery mode	A2	The current parameter	
Display Unit 1	d1	Blank	“+” “-”Keys are invalid in the operation.
Display suction temperature	NH	Suction temperature. For example, 15 represents 15°C	
Display discharge temperature	NP	Discharge temperature. For example, 70 represents 70°C	
Display low pressure	PL	Low pressure. For example, 95 represents 0.95Mpa	
Display high pressure	PH	High pressure. For example, 280 represents 2.80Mpa	

10.4 Parameters reference value for the normal operation of unit

No.	Parameters name	Unit	Reference value
1	Outdoor temperature	°C	—
2	Discharge temperature	°C	<ul style="list-style-type: none"> ◆ After compressor is started up, normal discharge temperature for cooling is 60~105°C , which is 10°C above more than the high pressure saturation temperature. ◆ The normal temperature for heating is 50°C ~100°C, which is 10°C above more than the high pressure saturation temperature.
3	High pressure	MPa	<ul style="list-style-type: none"> ◆ Under the cooling mode at the ambient temperature of 25~40°C , the high pressure value of the system is 2.2~3.5MPa; ◆ Under the heating mode when the ambient temperature is above -5°C . The high pressure value of the system is 2.0~3.5MPa.
4	Low pressure	MPa	<ul style="list-style-type: none"> ◆ Under the cooling mode at the ambient temperature of 25~40°C , the low pressure value of the system is 0.6~1.5MPa; ◆ Under the heating mode when the ambient temperature is above -5°C . The low pressure value of the system is 0.4~1.5MPa.
5	Current	A	Current should be no more than 20A during normal operation for compressor



MAINTENANCE

DEBUGGING & MAINTENANCE

1 Malfunction List

1.1 Error Code of Protection

Error Item	Code	Indoor Unit Display	Outdoor Unit Display
Indoor fan protection	L1	L1	L1
Water overflow protection	L3	L3	L3
Anti-freeze protection	L5	L5	L5
Mode conflict	L6	-	L6
Indoor ambient temperature sensor error	d3	d3	d3
Indoor coil inlet temperature sensor error	d4	d4	d4
Indoor mid-coil temperature sensor error	d5	d5	d5
Indoor coil outlet temperature sensor error	d6	d6	d6
Indoor humidity sensor error	d7	d7	d7
Jumper error	d9	d9	d9
Outdoor ambient temperature sensor error	b1	b1	b1
Outdoor heat-exchanger coil outlet temperature sensor error	b3	b3	b3
Vapor-liquid separator inlet temperature sensor error	b6	b6	b6
High pressure protection	E1	E1	E1
Low pressure protection	E3	E3	E3
Discharge protection	E4	E4	E4
Refrigerant-lacking protection	Ed	E0	Ed
Compressor power protection	EN	E0	EN
Intermediate vapor injection temperature sensor error	Fb	E0	Fb
EEPROM read-write error	F0	F0	F0
High pressure sensor error	F1	F1	F1
Middle pressure sensor error	F2	E0	F2
Low pressure sensor error	F3	F3	F3
Discharge temperature sensor error	F6	F6	F6
High pressure switch	Fd	E0	Fd
AC over current	P5	P0	P5
IPM over current protection	P6	E0	P6



IPM module overheat	P8	P0	P8
Desynchronizing protection	P9	P0	P9
Busbar over voltage protection	PH	P0	PH
Phase current detection fault	PC	P0	PC
Busbar under voltage protection	PL	P0	PL
Capacitor charge error	PF	P0	PF
Demagnetization protection	PU	P0	PU
Communication error between indoor and outdoor units, indoor unit's wired controller	C0	C0	C0
485 communication error between main controller and drive controller	C2	C2	C2
Fan motor error	H0	H0	H0
PFC over current protection	P4	E0	P4
PFC module overheat	Pn	P0	Pn
Phase loss protection of compressor	PE	P0	PE
Malfunction of lack of IDU	C4	C4	C4
485 communication error between main controller and debugging controller	C1	-	C1

1.2 Error Code of Limiting Frequency Reduction Protection

Error Item	Code	Display
Limited frequency reduction for high pressure protection	FA	Only the outdoor unit displays the code
Limited frequency reduction for low pressure protection	FH	
Limited frequency reduction for discharge temperature protection	F9	
Limited frequency reduction for AC current protection	F8	
Limited frequency reduction for power protection	FC	
Limited frequency reduction for IPM temperature protection	FL	
Limited frequency reduction for PFC temperature protection	FE	

1.3 Operation Code

Operation	Code	Indoor Unit Display	Outdoor Unit Display
Trail run	A0	A0	A0
Fluorine recycle	A2	A2	A2
Defrosting	A3	A3	A3
Oil return	A4	-	A4
Testing online	A5	A3	A4
Vacuumization	A8	A8	-
Test module	SS	-	SS

Note: Last ten records of protection shutdown or limited frequency reduction for protection can be searched through the debugging controller.

2 Troubleshooting

Troubleshooting principle

(1) Communication malfunction

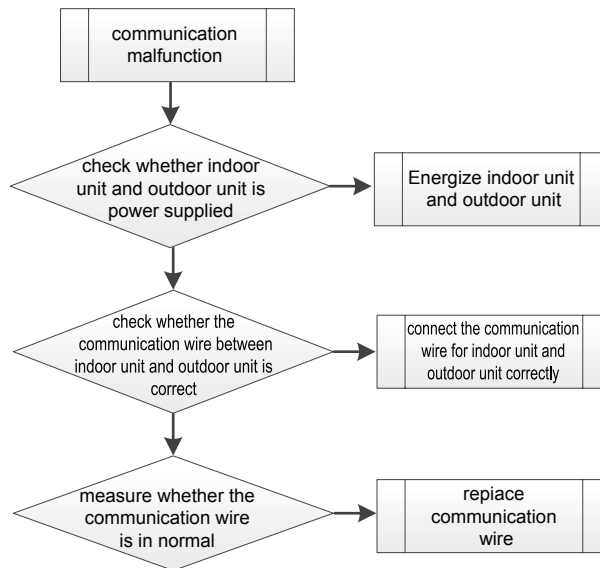

(2) Low-pressure protection

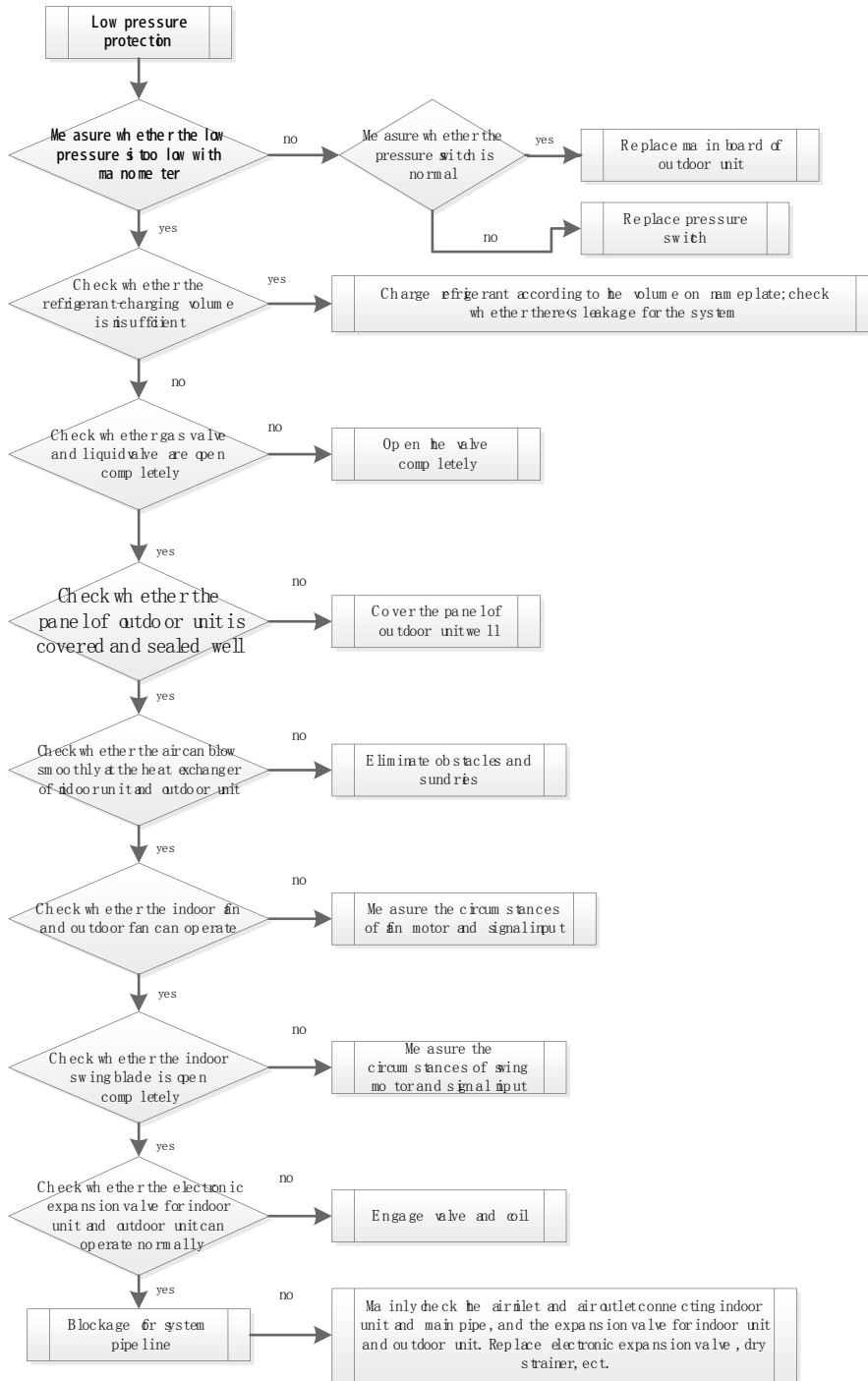

(3) Discharge temperature protection

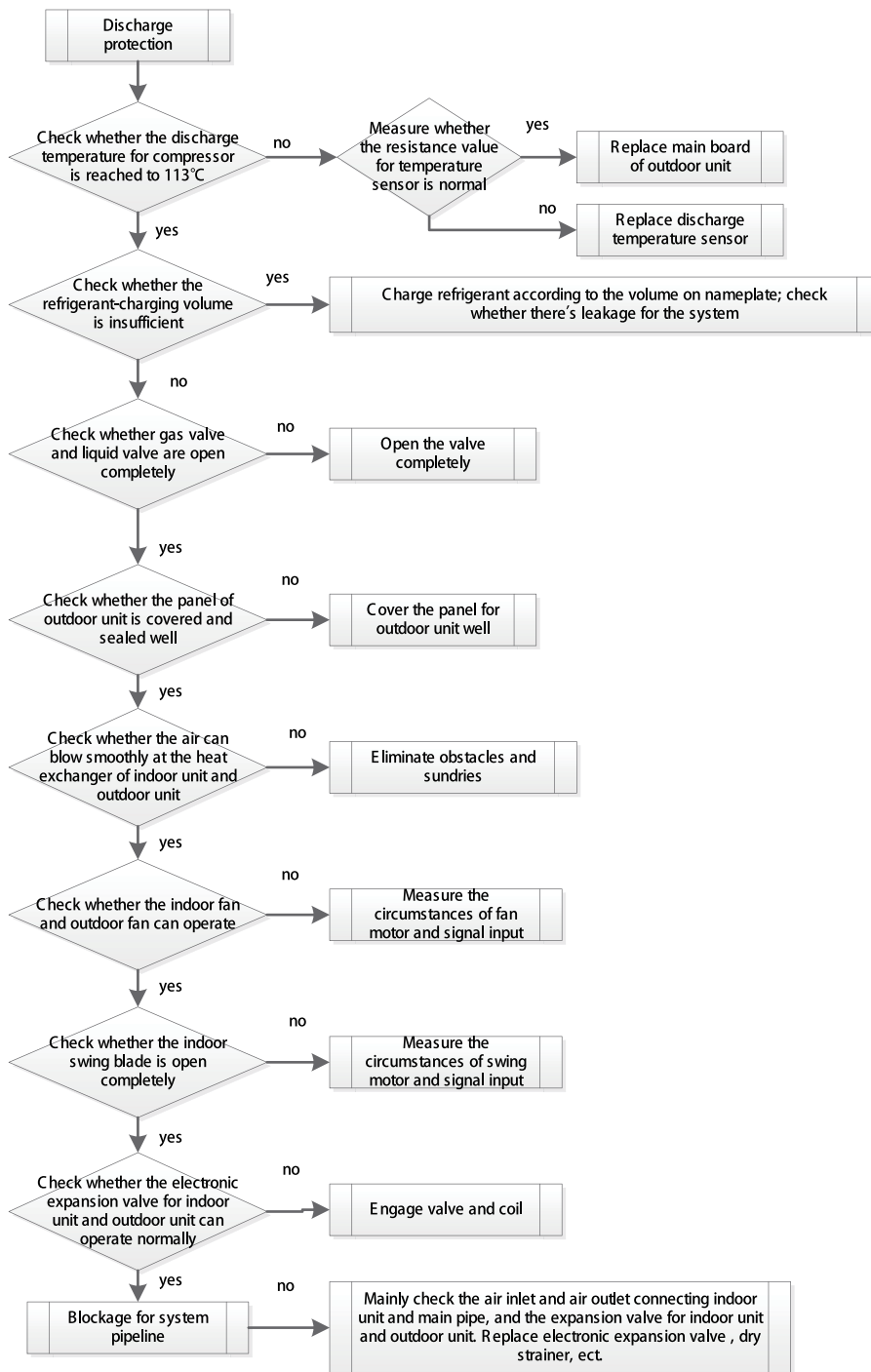

(4) Malfunction of temperature sensor

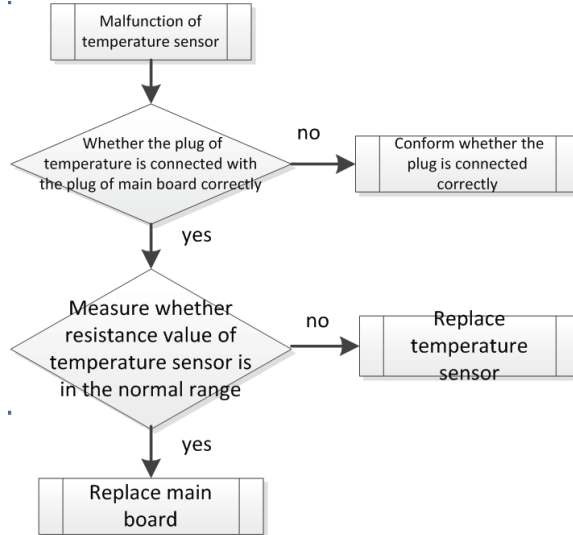

(5) Malfunction of sensor

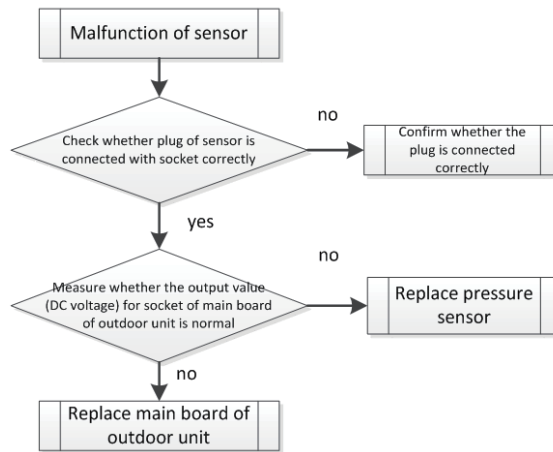

(6) Unit and main board can't be energized

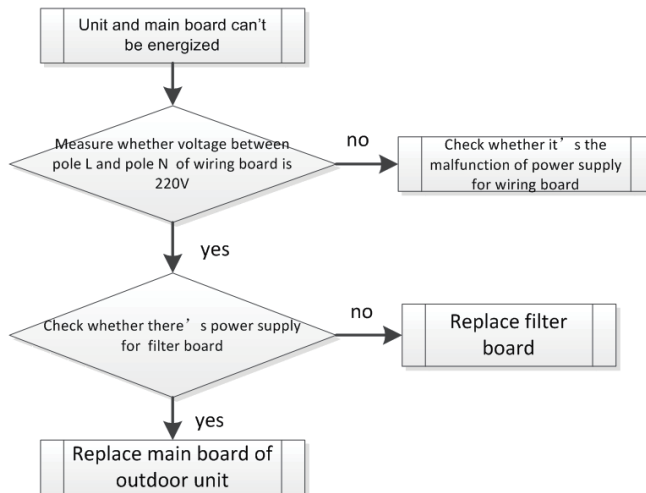

(7) Failure start-up

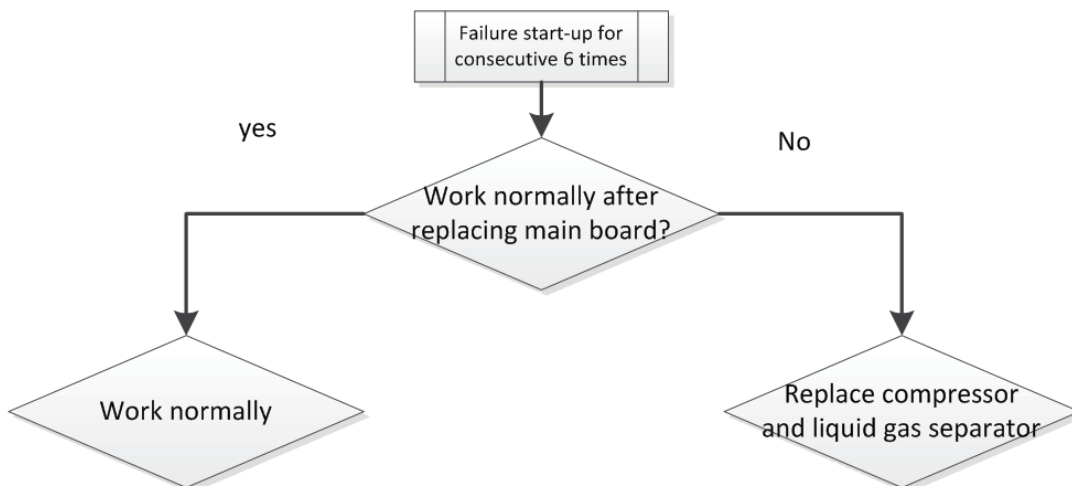

3 Power Distribution of Unit

3.1 Power distribution of unit

The control logical relationship among parts inside the electric box of unit is showed by the mongline diagram (CAD source file). The main loop is showed by bold line (line width: 1mm); the control loop is showed by slim line (line width: 0.2mm).

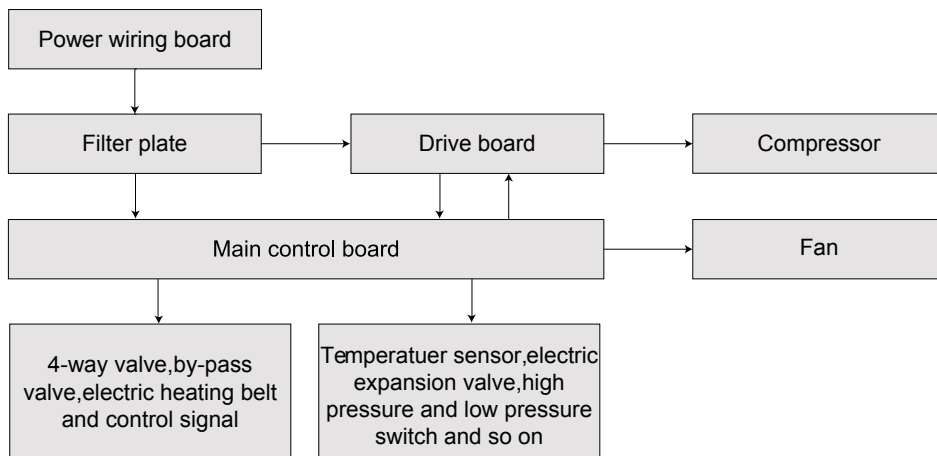

(Bold line is the power line and the slim line is the control line)

3.2 Main electric parts

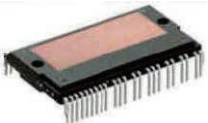
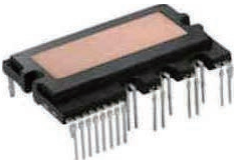
Name	Photo	Function introduction
IPM Module		There are three complementary IGBT tube inside the IPM module. They are controlled by PWM wave and then bring the pressure of DC bus bar to different stator windings of compressor at different stage, and then generate current on the stator. Meanwhile, magnetic field will be generated on the stator winding, and push the operation of rotor and then drive compressor to operate.
PFC module		Four diodes and two MOS pipe are integrated inside the PFC module. It will transform AC input power into DC power. Meanwhile, MOS pipe is controlled by PWM wave. Pressure will be increased by induction.

3.3 Circuit diagram

Note:

This drawing is just for reference; please always refer to the electric wiring stuck to the unit for actual wiring.

3.3.1 Circuit diagram of outdoor unit

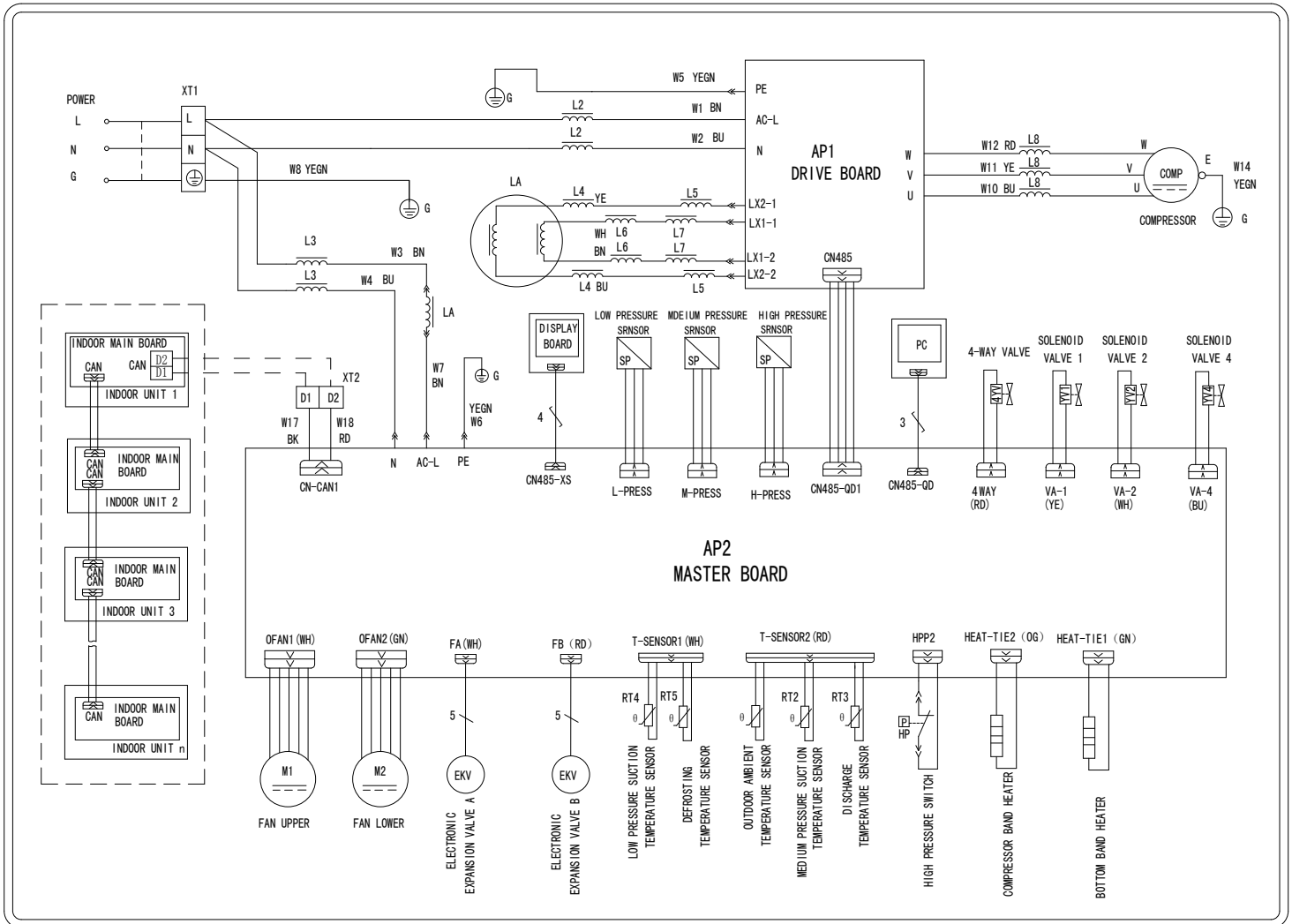

3.3.2 Circuit Diagram

(1) Low Static Pressure Duct Type IDU

GMV-ND07PLS/A-T(U) ~ GMV-ND22PLS/A-T(U):

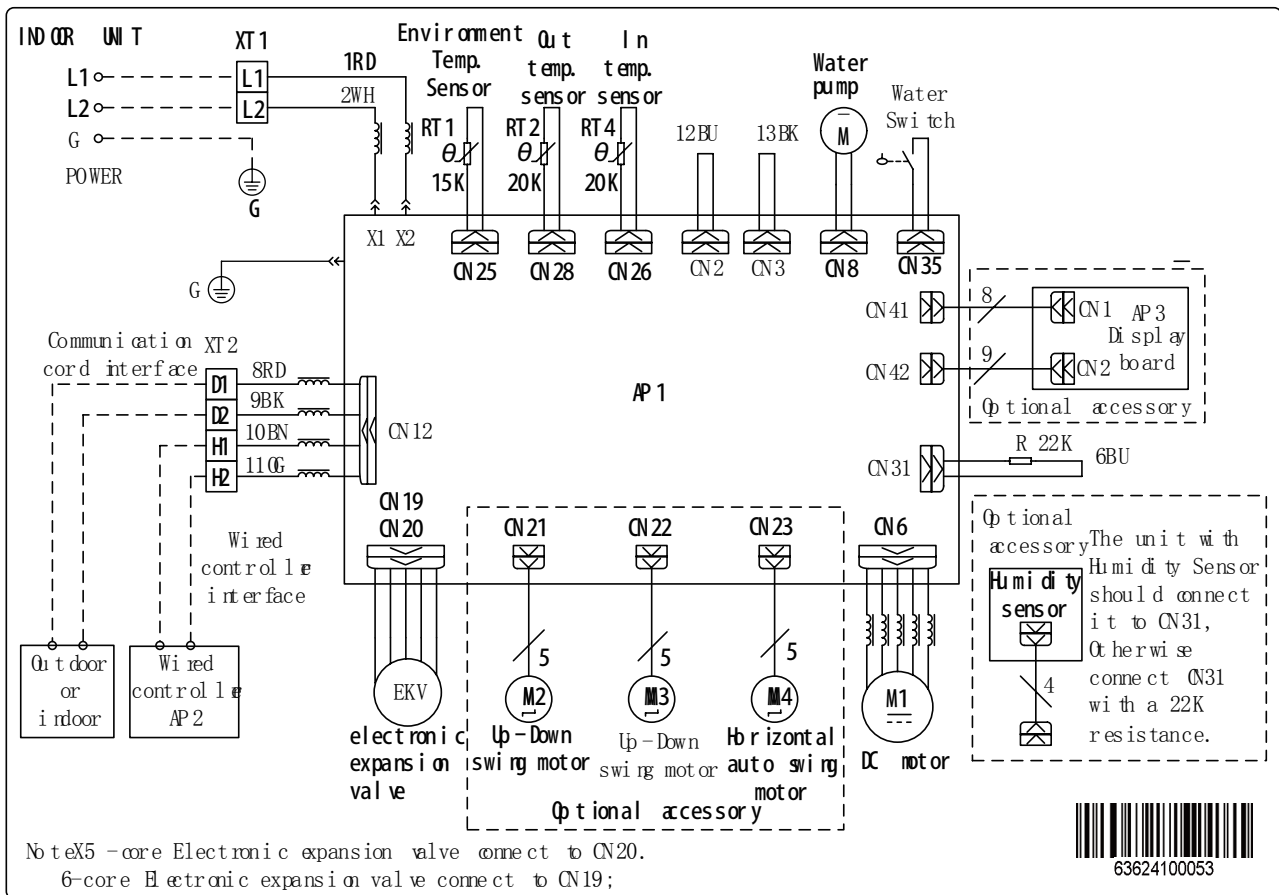

(2) 4-way Cassette Type IDU

GMV-ND07T/A-T(U) ~ GMV-ND48T/A-T(U):

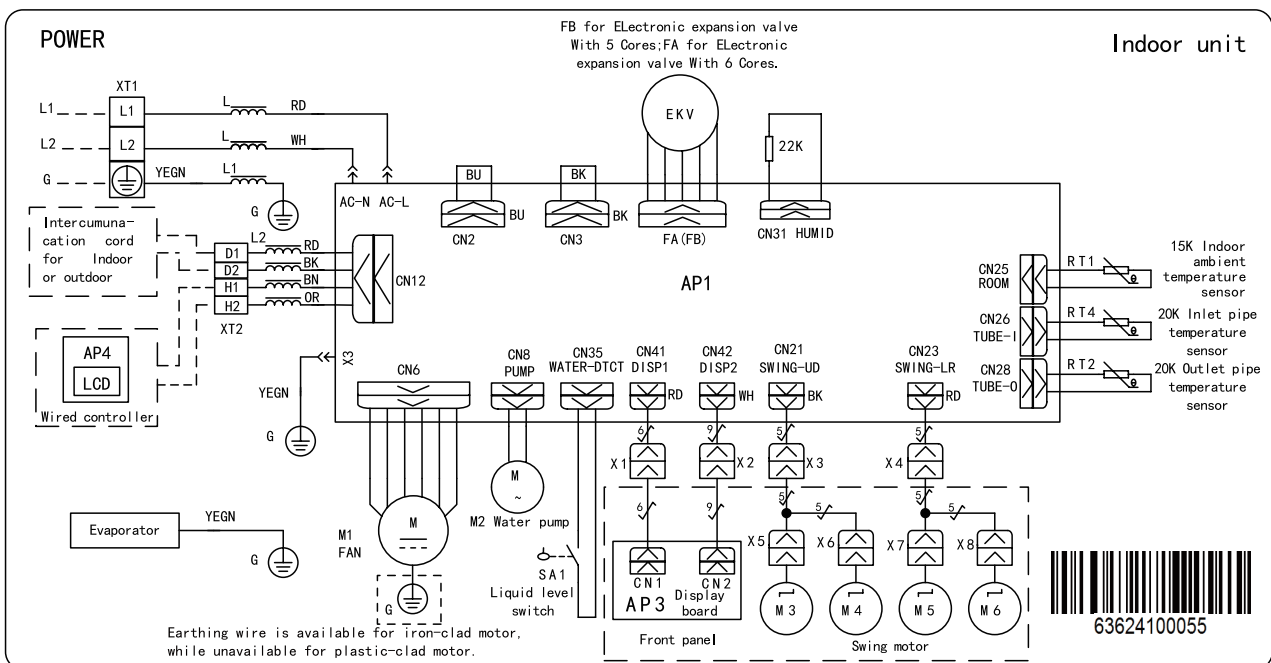

(3) Wall Mounted Type IDU
GMV-N07G/A3A-D(U)~GMV-N24G/A3A-D(U):

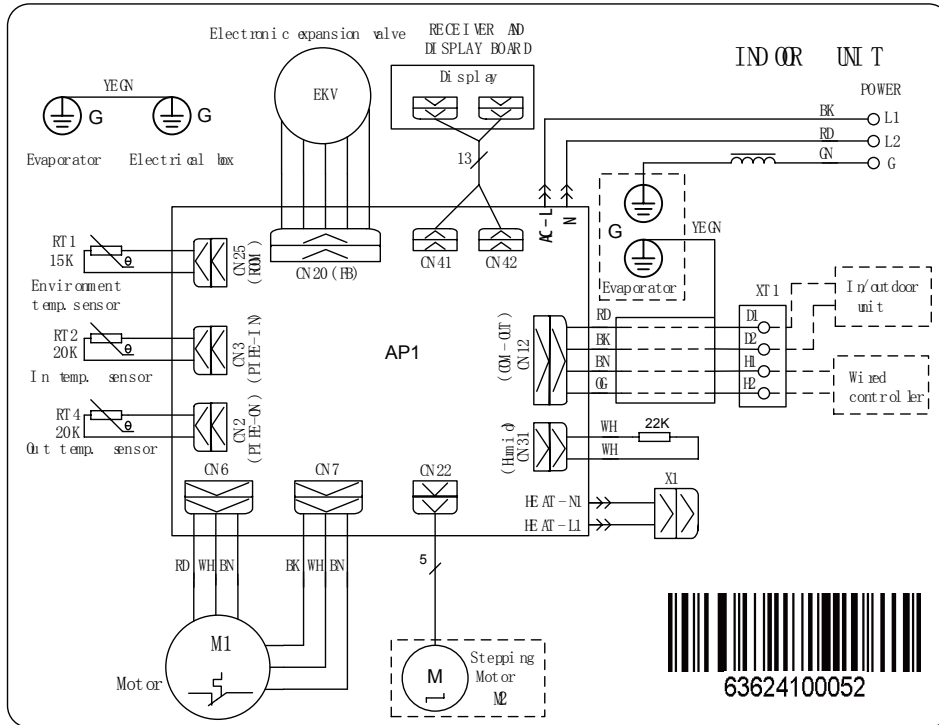

4 Removal of Parts

4.1 Key parts

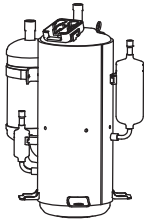
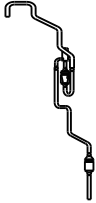
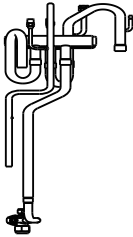
Photo	Name	Function
	compressor	Core part of air conditioning system. It sucks low temperature and low pressure gas, compress it to high temperature and high pressure gas, and then discharge it.
	Electronic expansion valve	Throttling device. It transforms high pressure refrigerant liquid into low pressure steam.
	4-way valve	It changes the flow direction of refrigerant for switching between cooling and heating.

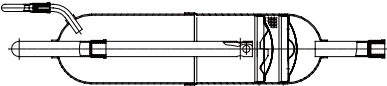
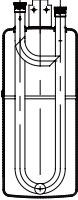
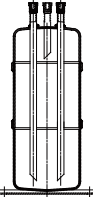
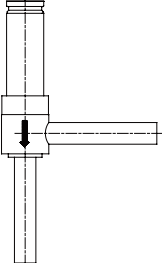
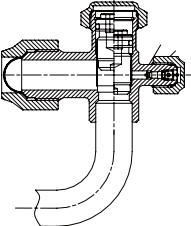
	<p>Oil separator</p>	<p>It stays between discharge outlet of compressor and inlet of condenser. It used for separating the lubricant oil of compressor when the high temperature and high pressure refrigerant gas is discharged from the compressor.</p>
	<p>Vapour liquid separator</p>	<p>It stays between outlet of evaporator and suction outlet of compressor. It used for separating low temperature and low pressure refrigerant.</p>
	<p>Accumulator</p>	<p>It used for separating middle pressure gas from the refrigerant, which will be sucked in the compressor.</p>
	<p>Solenoid valve</p>	<p>Control to the high-voltage current: open upon power on; close upon power off</p>
	<p>Cut-off valve</p>	<p>It used for connecting indoor unit and outdoor unit, and used for maintenance and installation.</p>

4.2 Removal of key parts

4.2.1 GMV-36WL/B-T(U)\GMV-48WL/B-T(U) series unit

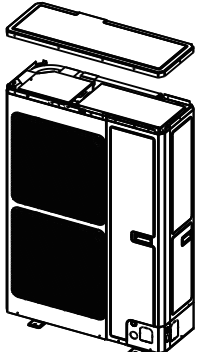
Removal operation for panel		
Remark: Before removing the panel, please make sure that the unit is disconnected with the power		
Process	Photo	Operation Instruction
<p>1. Remove top cover</p>		<ul style="list-style-type: none"> ● Loose the screws fixing the top cover with screwdriver ● Hold the top cover upwards and then put it on the floor flatly

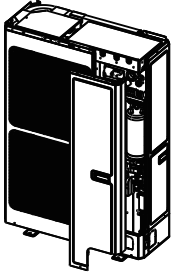
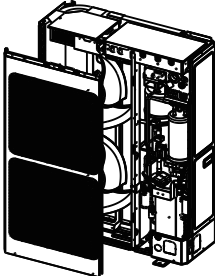
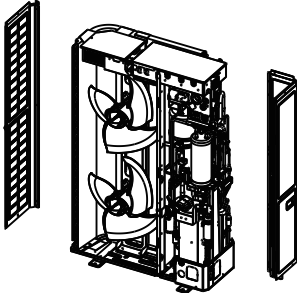

<p>2. Remove front side plate sub-assy</p>		<ul style="list-style-type: none"> • Loose the screw fixing the front side plate with screwdriver • Hold the front side plate upwards and then put it on the floor flatly
<p>3. Remove front panel and grille</p>		<ul style="list-style-type: none"> • Loose the screws fixing the front panel and grille with screwdriver • Put the front panel and grille on the floor flatly
<p>4. Remove left side plate and rear side plate</p>		<ul style="list-style-type: none"> • Loose screws fixing left side plate and rear side plate with screwdriver • remove the rear side plate

Removal operation for blade

Remark: Before removing the motor, please make sure that the unit is disconnected with the power.

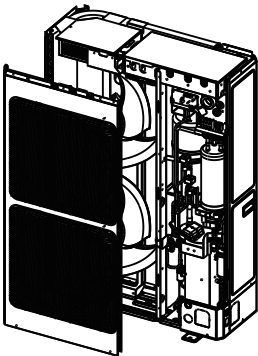
Process	Photo	Operation Instruction
<p>1. Remove grille</p>		<ul style="list-style-type: none"> • Loose screws fixing the panel with screwdriver • Then remove the grille

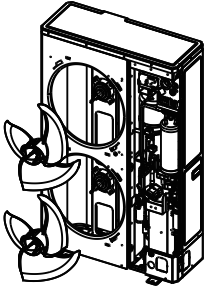
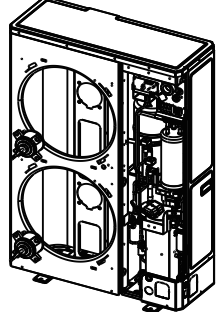
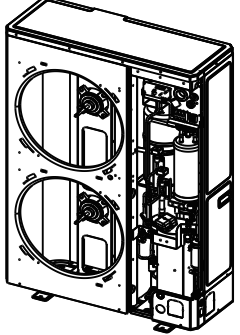
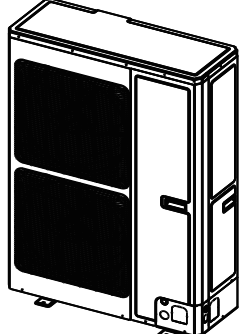
<p>2. Remove blade</p>		<ul style="list-style-type: none"> • Loosen nuts fixing the blade with wrench • Then remove the blade and put it on the floor flatly
<p>3. Remove motor</p>		<ul style="list-style-type: none"> • Loose screws fixing the motor with screwdriver • then remove the power cord of motor • Take out the damaged motor
<p>4. Install motor</p>		<ul style="list-style-type: none"> • Replace the motor, tighten screws with screwdriver and then connect teh power cord of motor
<p>5. Assemble unit</p>		<ul style="list-style-type: none"> • Assemble the unit in the the converse sequence

Removal operation of compressor

Remark: Before removing the compressor, please make sure that there's no refrigerant inside the pipeline and the power is disconnected.

<p>Process</p>	<p>Photo</p>	<p>Operation Instruction</p>
----------------	--------------	------------------------------

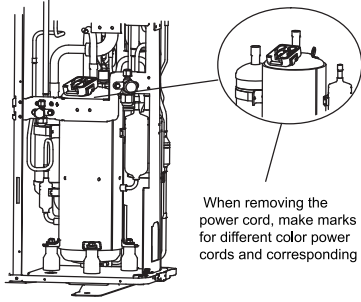
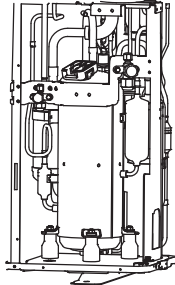
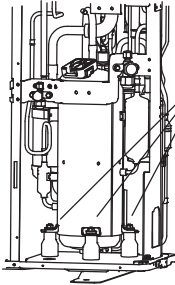
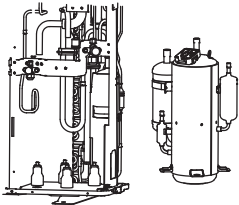
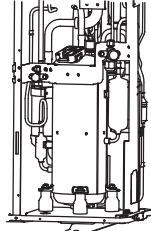
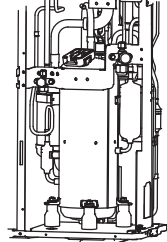

<p>1. Remove wiring cover of compressor</p>	 <p>When removing the power cord, make marks for different color power cords and corresponding</p>	<ul style="list-style-type: none"> • Loose screws fixing the compressor with screwdriver • Then pull out the power cord <p>Note: When removing the power cord, make marks for different color power cords and corresponding wiring terminals for wrong terminal.</p>
<p>2. Disconnect compressor and connected pipeline</p>		<ul style="list-style-type: none"> • Weld suction pipe and discharge pipe of compressor • then pull out the connection pipe from the compressor <p>Note: During welding process, do not let the flame burn out other parts.</p>
<p>3. Loose nuts fixing the foot of compressor</p>	 <p>Twist off four nuts for compressor with wrench</p>	<p>Twist off the nuts for compressor with wrench</p>
<p>4. Remove the chassis from compressor</p>		<ul style="list-style-type: none"> • Take out the compressor and replace it <p>Note: When replacing the compressor, do not damage nearby pipelines and other parts</p>
<p>5. Fix the new compressor at the chassis</p>		<p>After replacing the compressor, fix the nuts at the bottom of compressor</p>
<p>6. Connect suction pipe and discharge pipe of copressor and pipeline of system again</p>		<ul style="list-style-type: none"> • Weld the connection pipe of compressor, connect the pipeline and compressor <p>Note: During welding process, do not let flame burn out other parts</p>

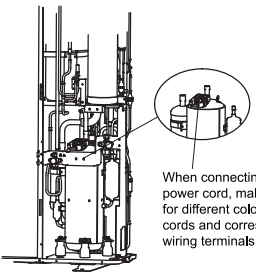
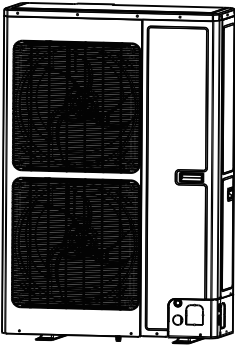
<p>7. Connect the power cord of compressor well</p>		<ul style="list-style-type: none"> • Loose screws fixing the power cord with screwdriver • connect the power cord well again <p>Note: When connecting the power cord, make marks for different color power cords and corresponding wiring terminals.</p>
<p>8. Check and open the upper cover plate</p>		<ul style="list-style-type: none"> • Check whether the pipeline is connected well • Check whether all parts and connection wires are connected well • If there's no problem after checking, install front and rear cover plates.

Removal operation for 4-way valve

Remark: Before removing the 4-way valve, please make sure that there's no refrigerant inside the pipeline of system and then power is disconnected.

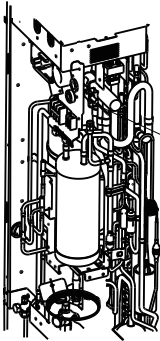
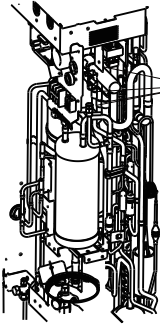
Process	Photo	Operation Instruction
<p>1. Disconnect the coil of 4-way valve from the 4-way valve</p>		<ul style="list-style-type: none"> • Remove the coil of 4-way valve at first
<p>2. Disconnect the 4-way valve and connection pipeline</p>		<ul style="list-style-type: none"> • Weld those 4 connection spots on 4-way valve, and then pull out the connection pipe <p>Note: During welding process, do not let the flae burn out other parts</p>

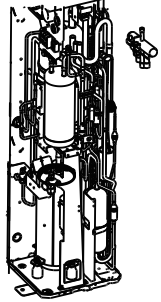
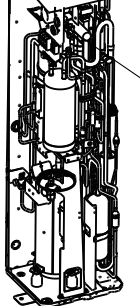

<p>3. Replace 4-way valve</p>		<ul style="list-style-type: none"> • Replace 4-way valve <p>Note: During welding process, do not let the flame burn out other parts</p>
<p>4. Replace 4-way valve</p>	 <p>Remove the coil of 4-way valve at first</p>	<ul style="list-style-type: none"> • Weld the connection position between 4-way valve and pipeline <p>Note: During welding process, do not let flame burn out other parts</p>

Removal operation for electronic expansion valve

Remark: Before removing the electronic expansion valve, please make sure that there's no refrigerant in th pipeline of system and the power is disconnected

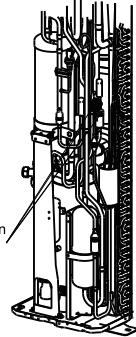
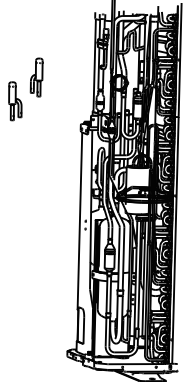
Process	Photo	Operation Instruction
<p>1. Disconnect the electronic expansion valve from the pipeline</p>	 <p>Weld the connection pipe for expansion valve</p>	<ul style="list-style-type: none"> • Remove the coil of electroc expansion valve at first • Weld the connection pipe for expansion valve, and then pull out the connection pipe <p>Note: During welding process, do not let flame burn out other parts</p>
<p>2. Take out the electronic expansion valve and replace it</p>		<p>Take out the electronic expansion valve and replace it</p>

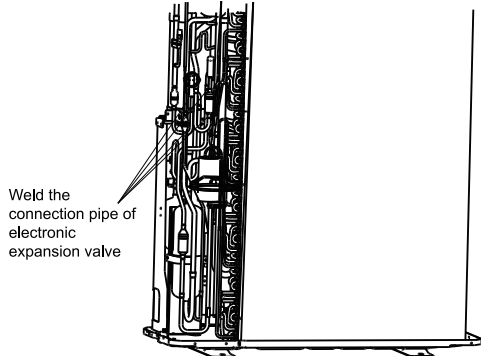
<p>3. Replace electronic expansion valve</p>		<ul style="list-style-type: none"> • Weld the connection pipe of electronic expansion valve • Install the coil of electronic expansion valve <p>Note: During welding process, do not let the flame burn out other parts</p>
--	---	---

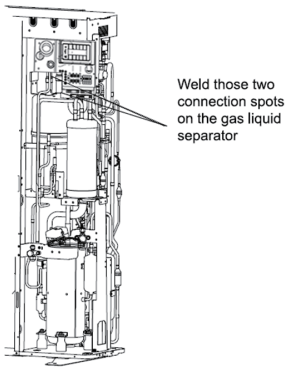
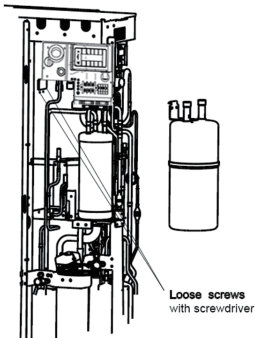
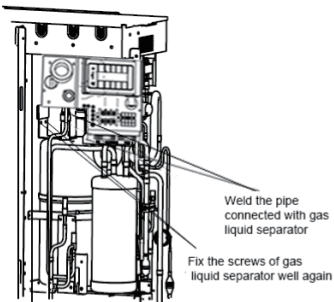
Removal operation of gas liquid separator		
Remark: Before removing the gas liquid separator, please make sure that there's no refrigerant inside the pipeline of system and disconnect the power		
Process	Photo	Operation Instruction
<p>1. Disconnect inlet pipe and exit pipe of gas liquid separator</p>		<ul style="list-style-type: none"> • Weld those two connection spots on the gas liquid separator and then pull out the connection pipe <p>Note: During welding process, do not let flame burn out other parts</p>
<p>2. Replace gas liquid separator</p>		<ul style="list-style-type: none"> • Loose screws with screwdriver • Replace gas liquid separator
<p>3. Replace gas liquid separator</p>		<ul style="list-style-type: none"> • Weld the pipe connected with gas liquid separator • Fix the screws of gas liquid separator well again <p>Note: During welding process, do not let flame burn out other parts</p>



4.3 Assembling and Disassembling Key Parts of IDUs6 Common Maintenance

◆ Low static pressure duct

Note: The following steps are specific for GMV-ND07PLS/A-T(U) units. For other units, the assembly and disassembly procedure is similar except the numbers of louvers and motors.

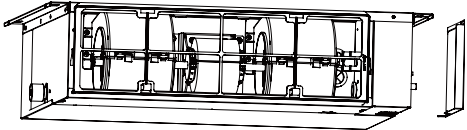
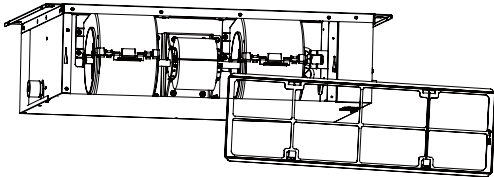
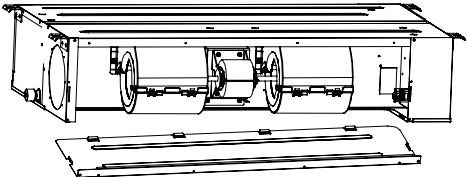
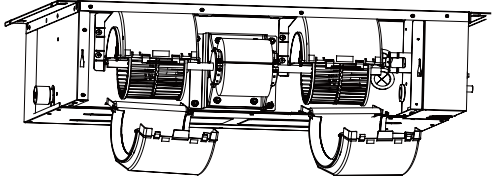
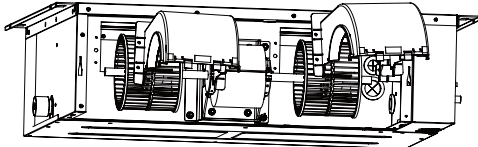
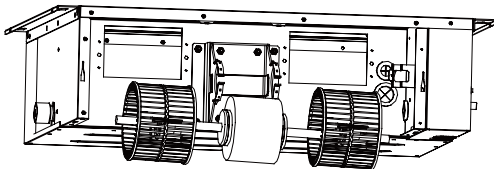
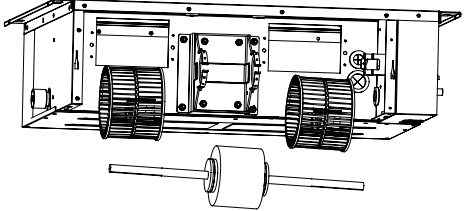
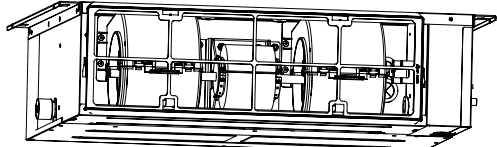
Motor and fan		
Precondition: The power supply has been disconnected.		
Step	Diagram	Operation Procedure
1. Remove the line connecting to the motor.		<ul style="list-style-type: none"> ● Use a screwdriver to unscrew the electric box cover. ● Remove from the master board the line connecting to the motor and remove the tie.
2. Remove the filter.		<ul style="list-style-type: none"> ● Remove the filter from the air return frame.
3. Remove the air return cover plate.		<ul style="list-style-type: none"> ● Use a screwdriver to unscrew the air return cover plate.
4. Remove the rear propeller housing.		<ul style="list-style-type: none"> ● Loosen the fasteners that connect the rear propeller housing with the front propeller housing and remove the rear propeller housing.
5. Remove the front propeller housing.		<ul style="list-style-type: none"> ● Use a screwdriver to unscrew the front propeller housing and then remove the propeller housing.
6. Loosen the louver and motor.		<ul style="list-style-type: none"> ● Use a hexagon to unscrew the louver and loosen the fasteners of the motor.
7. Remove the motor.		<ul style="list-style-type: none"> ● Remove the motor from the support and remove the louver from the motor axle. Then, remove the motor. ● For motors that are accompanied with supports, the supports need removing as well.
8. Install a new motor.		<ul style="list-style-type: none"> ● Assemble units based on the reverse order of this procedure and power on the units for test.

◆ Four-way Cassette

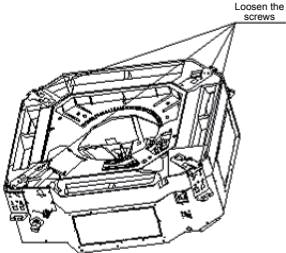
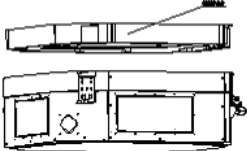
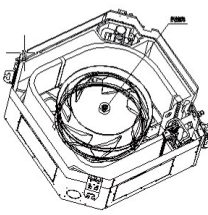
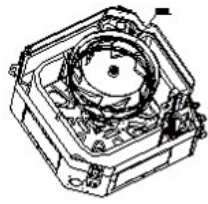
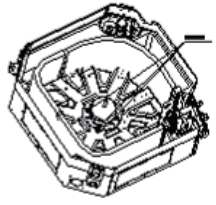
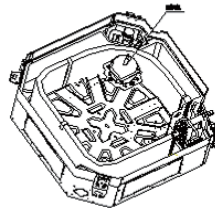
Motor and fan		
Step	Diagram	Operation Procedure
1. Unscrew the water tray.		<ul style="list-style-type: none"> ● Use a screwdriver to unscrew the water tray.
2. Remove the water tray.		<ul style="list-style-type: none"> ● Remove the water tray.
3. Unscrew the louver.		<ul style="list-style-type: none"> ● Use a wrench to unscrew the louver.
4. Remove the louver.		<ul style="list-style-type: none"> ● Remove the louver.
5. Unscrew the motor.		<ul style="list-style-type: none"> ● Use a screwdriver to unscrew the motor.
6. Replace the motor with a new one.		<ul style="list-style-type: none"> ● Replace the motor with a new one.

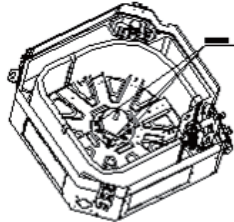
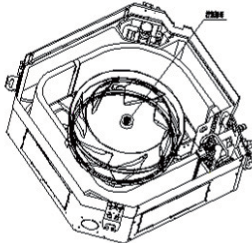
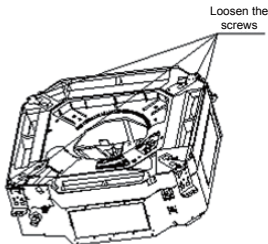

<p>7. Screw the motor.</p>		<ul style="list-style-type: none"> ●Use a screwdriver to screw the motor.
<p>8. Install and screw the louver.</p>		<ul style="list-style-type: none"> ●Install the louver and use a wrench to screw the louver.
<p>9. Install and screw the water tray.</p>		<ul style="list-style-type: none"> ●Use a screwdriver to screw the water tray

Pump

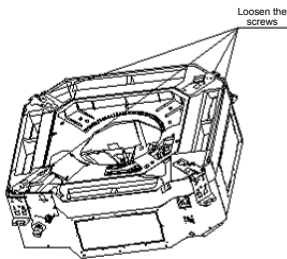
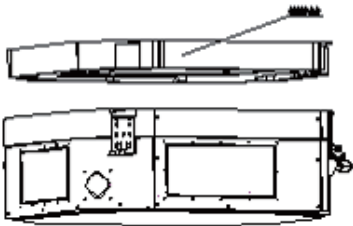
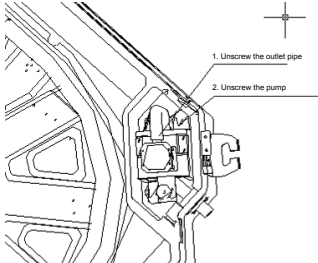

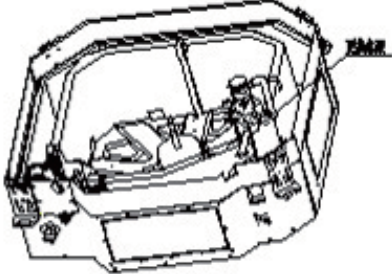
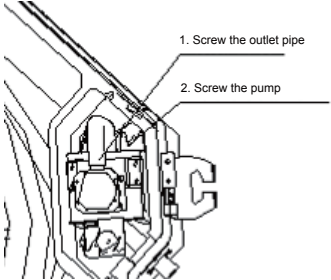
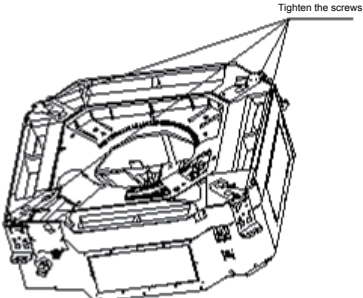
Step	Diagram	Operation Procedure
<p>1. Unscrew the water tray.</p>		<ul style="list-style-type: none"> ●Use a screwdriver to unscrew the water tray.
<p>2. Remove the water tray.</p>		<ul style="list-style-type: none"> ●Replace the water tray.
<p>3. Remove the drainage duct and unscrew the pump.</p>		<p>3. Remove the drainage duct and use a screwdriver to unscrew the pump.</p>

<p>4. Replace the pump.</p>		<ul style="list-style-type: none"> ● Replace the pump.
<p>5. Connect the drainage duct and screw the new pump.</p>		<ul style="list-style-type: none"> ● Connect the drainage duct and use a screwdriver to screw the new pump.
<p>6. Install and screw the water tray.</p>		<ul style="list-style-type: none"> ● Use a screwdriver to screw the water tray.

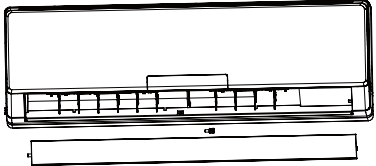
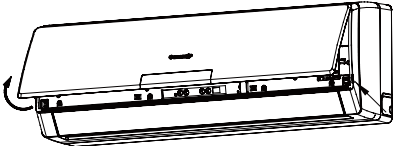
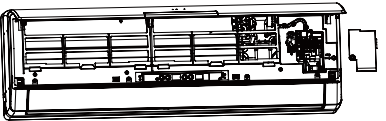
◆ Wall Mounted Type IDU

Removal of Fan Motor		
Remark: before removing, making sure power is disconnected.		
Step	Diagram	Operation Procedure
<p>1. Remove the louver</p>		<ul style="list-style-type: none"> ● Take off the axle bush of the louver. ● Remove the louver.
<p>2. Open the front panel</p>		<ul style="list-style-type: none"> ● Hold the indents on both sides of the panel and pull it out in the direction shown by the arrow.
<p>3. Remove the electrical box cover 2</p>		<ul style="list-style-type: none"> ● Unscrew the screws fixing the electrical box cover with a screwdriver. Take off the box cover 2. ● Detach the ambient temperature sensor from the conduit.

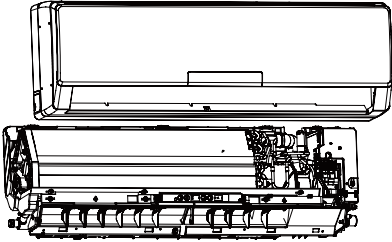

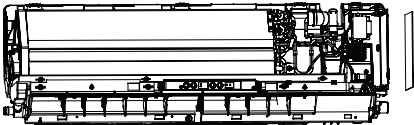
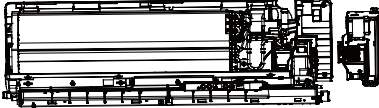
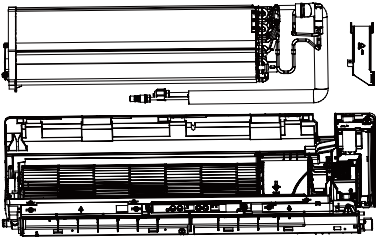
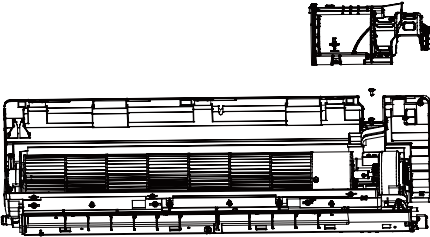
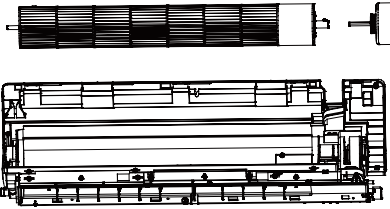
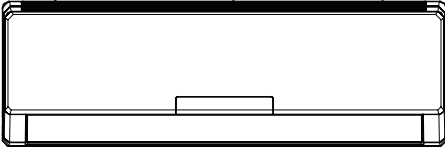
<p>4. Remove the front panel assembly</p>		<ul style="list-style-type: none"> ● Unscrew the screws fixing the front panel assembly. ● Remove the front panel assembly.
<p>5. Remove the electrical box cover 1</p>		<ul style="list-style-type: none"> ● Press on the buckle of the box cover 1 and then take off the cover.
<p>6. Remove the main board</p>		<ul style="list-style-type: none"> ● Release the wiring terminals connected to the main board. ● Remove the main board.
<p>7. Remove the electrical box</p>		<ul style="list-style-type: none"> ● Unscrew the screws fixing the electrical box with a screwdriver. ● Remove the electrical box.
<p>8. Remove the evaporator</p>		<ul style="list-style-type: none"> ● Use a screwdriver to unscrew the screws fixing the press plate of connection pipe on the back of the unit and take off the press plate. ● Unscrew the screws of evaporator with a screwdriver and then remove the evaporator.
<p>9. Remove motor's pressing plate</p>		<ul style="list-style-type: none"> ● Unscrew the fixing screws of the pressing plate with a screwdriver and then remove it.
<p>10. Remove the motor and fan</p>		<ul style="list-style-type: none"> ● Take off the motor and fan directly. ● Use a screwdriver to unscrew the screws connecting the motor and the fan.
<p>11. Install a new motor.</p>		<ul style="list-style-type: none"> ● Assemble units based on the reverse order of this procedure and power on the units for test.

5 Vacuum drying for the system

5.1 Selection requirement for the vacuum pump

- Do not use different vacuum pump for vacuum-pumping for different refrigerant system
- The final vacuum for the vacuum pump should reach -0.1MPa .
- The air discharge volume for the vacuum pump should reach 4L/S above;
- The precision of vacuum pump should reach 0.02mmHg above;
- The system vacuum pump for R410A must be with check valve.

5.2 Operation procedure and notices for Vacuum drying

1) Operation procedure

- a. Before vacuum-pumping, please confirm that the cut-off valve for gas pipe and liquid pipe is at off status;
 - b. Use charging conduct pipe to connect the governing valve and vacuum heat pump to the detection joint of gas valve and liquid valve;
 - c. After vacuum-pumping for 4h, check whether the vacuum degree is reached to -0.1MPa or above; If not, there may be gas leakage. Please perform the leakage inspection again. If there's no gas leakage, please vacuum pump for another 2h.
 - d. If the required vacuum degree cannot be satisfied after vacuum-pumping for two times, there are water inside the pipeline. please drain out the water by the method of vacuum damage. The detailed method: charge 0.05MPa nitrogen into the pipeline, vacuum pump for 2h and then keep the vacuum for 1h. If -0.1MPa vacuum degree still can't be reached, repeat this operation until the water is drained out completely.
 - e. After evacuation, close the regulating valve, and 1 hour later check if its pressure goes up or not.
- 2) After the vacuum pump is finished, turn off the valve of governing valve and stop vacuum pump and keep it for 1h. Please confirm that the pressure of governing valve hasn't been increased.

- a. Vacuum pump for the gas pipe and liquid valve at the same time;

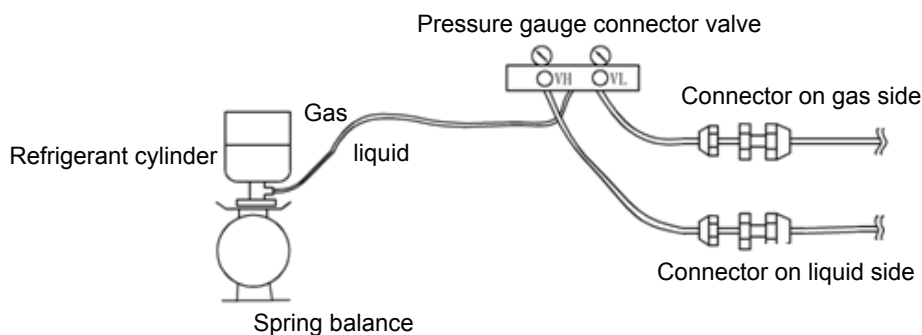

- b. When turn off the vacuum pump to stop vacuum-pumping, please turn off the valve at first and then de-energize the vacuum pump;
- c. Keep the vacuum pump for 2h and confirm that the pressure of vacuum meter hasnot been increased;

5.3 Fill and charge refrigerant

5.3.1 Filling procedure of refrigerant

Refrigerant quantity of outdoor unit before delivery:

Model	GMV-36WL/B-T(U)	GMV-48WL/B-T(U)
Refrigerant Qty (kg/oz)	6.5(229)	6.5(229)

NOTICE

- (1) The refrigerant amount charged before delivery doesn't include the amount that needs to be added to indoor units and the connection pipeline.
- (2) Length of connection pipe is decided on site. Therefore the amount of additional refrigerant shall be decided on site according to the dimension and length of field-installed liquid pipe.
- (3) Record the amount of additional refrigerant for convenience of after-sales service.

Calculation of the amount of additional refrigerant

Calculation method of the quantity of additional refrigerant (based on liquid pipe)

Quantity of additional refrigerant = \sum length of liquid pipe X quantity of additional refrigerant per meter(39-3/8inch)

Diameter of liquid pipe (mm/inch)	Φ22.2(7/8)	Φ19.05(3/4)	Φ15.9(5/8)	Φ12.7(1/2)	Φ9.52(3/8)	Φ6.35(1/4)
kg/m	0.35	0.25	0.17	0.11	0.054	0.022
oz/inch	0.314	0.224	0.152	0.099	0.048	0.020

NOTICE! Liquid pipe that is within 20m (65-5/8feet) doesn't need to be added with refrigerant.

First confirm that there is no leakage from the system. When compressor is not working, charge additional R410A with specific amount to the unit through the filling opening of the liquid pipe valve of the outdoor unit. If required amount cannot be quickly filled due to pressure increase of the pipe, then set the unit in cooling startup and fill refrigerant from the low pressure check valve of the outdoor unit.

(4) Calculation example

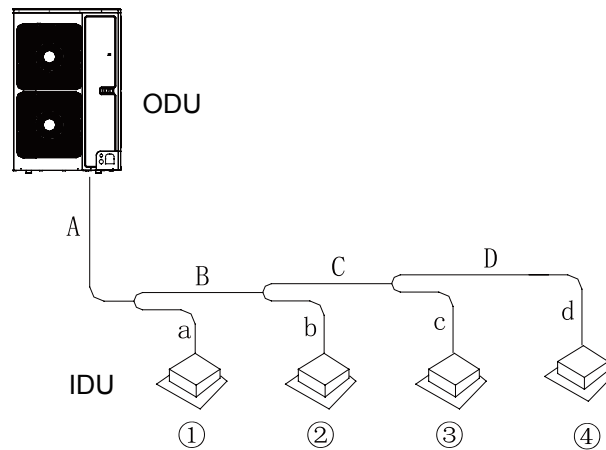

Indoor unit

No.	IDU ①	IDU ②	IDU ③	IDU ④
Model	Duct type GMV-ND18PLS/A-T(U)	Duct type GMV-ND12PLS/A-T(U)	Duct type GMV-ND09PLS/A-T(U)	Duct type GMV-ND09PLS/A-T(U)

Liquid pipe:

No.	A	B	C	D
Pipe size	φ9.52mm(3/8inch)	φ9.52 mm(3/8inch)	φ9.52 mm(3/8inch)	φ6.35 mm(1/4inch)
Length	10m(32-3/4feet)	5m(16-3/8feet)	5m(16-3/8feet)	5m(16-3/8feet)
No.	a	b	c	d
Pipe size	φ9.52mm(3/8inch)	φ6.35 mm(1/4inch)	φ6.35 mm(1/4inch)	φ6.35 mm(1/4inch)
Length	3m(9-3/4feet)	3m(9-3/4feet)	2m(6-5/8feet)	1m(3-1/4feet)

Total length of each liquid pipe

φ9.52: A+B+C+a=10+5+5+3=23m(75-1/2 feet)

φ6.35: D+b+c+d=5+3+2+1=11m(36feet)

NOTICE! Liquid pipe that is within 20m(65-5/8 feet) doesn't need to be added refrigerant.

Therefore, the minimum quantity of additional refrigerant = $(23-20) \times 0.054 + 11 \times 0.022 = 0.404\text{kg}(14\text{oz})$.

5.3.2 Operation procedure for adding refrigerant

- (1) Put the charging tank on the weightometer, record the reading and then calculate the data after charging refrigerant;
- (2) Use charging conduct pipe to connect the double-ended manometer with governing valve and liquid-charging tank to the detection head of gas valve and liquid valve. Before connection, please release some refrigerant and then drain out the air inside the charging conduct pipe.
- (3) Confirm that the gas valve and liquid for outdoor unit is at of status.
- (4) When the unit hasn't been turned on, open the governing valve for the liquid-charging tank and then charge refrigerant from gas pipe and liquid pipe at the same time.
- (5) Observe the data weightometer, close the valve after it is reached to requirement and then close the valve for liquid-charging tank;
- (6) If the refrigerant can't be added completely, add it when turning on the unit. Charge refrigerant from the detection joint of cooling gas pipe or detection joint of gas vavle.

5.3.3 Notice for filling refrigerant

- (1) Calculate the section and length of cooling liquid pipe preciously for the precision refrigerant-charing volume.
- (2) Measure the additional refrigerant volume preciously;
- (3) Invert to charge the R410A for ensuting the liquid-charging;
- (4) When the temperature is low, heat the liquid-storage tank with hot water or hot wind for helping refrigerant-charging. However, prohibit use flame to heat the liquid-storage tank directly. Otherwise, it may cuase personal injury or property damage due to explosion.

5.4 Airtightness test**5.4.1 Importance of airtightness test**

The airtightness of VRF system is the leak tightness of the pipeline for refrigerant, which the guarantee for safe and reliable operation. The leakage of refrigerant may affect the operation of air conditioner seriously, or even damage compressor and then lead to breakdown of system. Therefore, it needs to perform the airtightness test.

If the there's gas leakage after the system is installed completely, because the indoor celling decoration are all finished, it is will be very difficult to find out the leakage point. Thus, the airtightness test of the system must be finished before finishing indoor decoration.

5.4.2 Operation procedure for the airtightness test

- (1) Before ex-factory, cut-off valve for gas pipe and liquid pipe of outdoor unit is turned off, Please confirm that before operation;
- (2) Before test please smear a little corresponding lubricant oil at Blanking plug and pipe terminal, and use two wrenches for fixing blanking plug.
- (3) Do not allow to connect the pipeline of outdoor unit for test during airtightness test.
- (4) The system test pressure for R410A is 4.15MPa (3.0MPa for R22 refrigerant system). Nitrogen must be used as the medium for the airtightness test and the nitrogen should be dry. Increase pressure slowly for three steps:



- Step 1: Increase pressure slowly to 0.5MPa, stop for 5min and then check the gas leakage. Big leakage may be found out;
- Step 2: Increase pressure slowly to 1.5MPa, stop for 5min to check the airtightness. Small leakage may be found out;
- Step 3: Increase pressure slowly to 4.15MPa for R410A slowly (3.0MPa for R22 refrigerant system), stop for 5min and perform the strength test. Minor leakage or sand hole may be found. Increase pressure to test pressure, keep it for 24h and observe whether the pressure is decreasing. If not, the pressure is qualified.

5.4.3 Cautions

- The test manometer range for R410A should be 4.5MPa above (3.5MPa above for R22 refrigerant system);
- Record the data on manometer, ambient temperature and test time at the same time;
- Pressure modification: when temperature changes 1 °C, the pressure will change 0.01MPa correspondingly.
- Pressure should be kept the same.
- If it needs to keep pressure for a long time, decrease the pressure lower than 0.55MPa or below. Long-time high pressure can lead to leakage at the welding position, which may cause risk.
- Before the airtightness for the pipeline of refrigerant is finished, do not allow to insulate and bundle the welding positions and connection position of bellmouth of indoor unit.

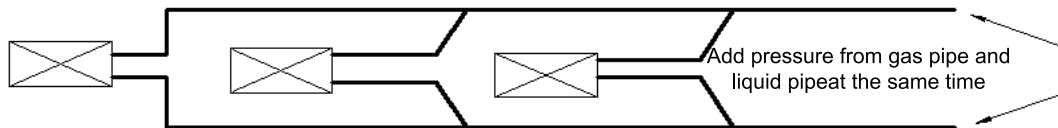

Note: Before airtightness test, all welding lines can't be insulated and bundled.

6 Exploded View of Unit and Parts' List

6.1 Exploded view for outdoor unit and parts' list

(1) Model: GMV-36WL/B-T(U)\GMV-48WL/B-T(U)

Exploded view:

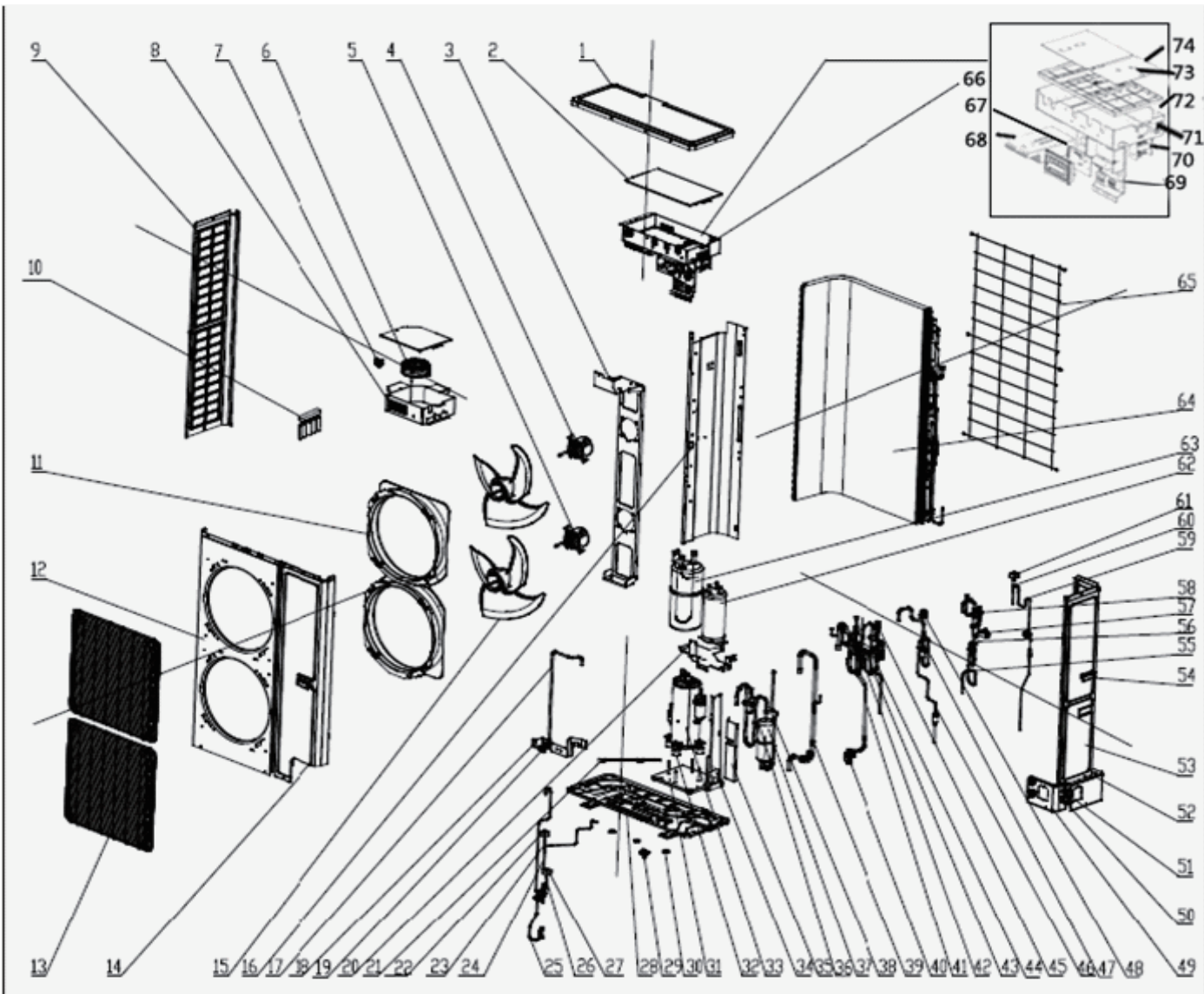

Parts list:

NO.	Name of Part	GMV-36WL/B-T(U)\GMV-48WL/B-T(U)	
		Product Code	CN850W0380\CN850W0360
		Part Code	Quantity
1	Coping	01264100008P	1
2	Electric Box Cover	012020000071	1
3	Motor Support Sub-Assy	017012000032	1
4	Brushless DC Motor	15704100013	1
5	Brushless DC Motor	1570410001301	1
6	PFC Inductance	340032000005	1
7	Cable Cross Loop	76512008	1
8	Inductance Box Sub-assy	01394100625	1
9	Left Side Plate	01314100013P	1
10	Sensor Sub-assy	39008000141G	1
11	Diversion Circle	10474100001	1
12	Cabinet	01514100002P	1
13	Front Grill	01574100009	1
14	Front Side Plate	01314100012P	1
15	Axial Flow Fan	10434100004	2
16	Clapboard Sub-Assy	1244100043	1
17	Cut off Valve Sub-Assy	07334100077	1
18	Joint Plank groupware	01344100113	1

19	Liquid side stop Valve	0733000002	1
20	Underlay groupware	01894100090	1
21	Electrical Heater(compressure)	7651521215	1
22	Magnet Coil	4304000425	1
23	Electromagnetic Valve	43000054	1
24	Electromagnetic Valve groupware	43044100234	1
25	Electromagnetic Valve groupware	43044100232	1
26	Electromagnetic Valve	43003091	1
27	Magnet Coil	4304000439	1
28	Chassis Sub-assy	01194100051P	1
29	Drainage Connector	06123401	1
30	Nage hole Cap	06813401	3
31	Fixity groupware (Compressor)	01844100082P	1
32	Compressor Gasket	009012000013	4
33	Compressor	00204100030	1
34	Underlay	01894100088	1
35	Underlay	01854100009	1
36	Pressure Protect Switch	4602001587	1
37	Oil Separator	07424105	1
38	Discharge Tube Sub-assy	04514100561	1
39	Suction Tube Sub-assy	04574100170	1
40	Gas side stop Valve	07334100079	1
41	4-Way Valve Assy	030152000095	1
42	Sensor (Low Pressure)	322101002	1
43	Magnet Coil	4304000431	1
44	4-way Valve	43000338	1
45	Sensor (High Pressure)	322101032	1
46	Electric Expansion Valve Sub-Assy	43044100233	1
47	Electronic Expansion Valve	43044100172	1
48	Electric Expand Valve Fitting	4304413205	1
49	Front Connection Board	01344100002P	1
50	Gland Bush	26904100134	1
51	Pipe for wire	26904100132	1
52	Right Connection Board	01344100003P	1
53	Rear Side Plate	01314100014P	1
54	Handle	26904100016	2
55	Pipeline groupware	030205000005	1
56	Electronic Expansion Valve	3044100173	1
57	Electric Expand Valve Fitting	4304413220	1
58	Sensor(High Pressure)	322101036	1
59	Oil Returning Pipe Sub-assy	04224100556	1
60	Electromagnetic Valve	43003091	1
61	Magnet Coil	4304000415	1
62	Accumulator	07424100031	1
63	Gas-liquid Separator	07424140	1
64	Condenser Assy	000100000022	1
65	Rear Grill	01574100004	1
66	Electric Box Assy	100002000222	1
67	Testing Board	30118000096	1
68	Radiator	49018000136	1
69	Cable Cross Loop	43138000047	2
70	Reactor	07424140	1
71	Electric Box Sub-Assy	01394100626	1
72	Electric Box	26904100086	1
73	Main Board	300027000025	1
74	Gas-liquid Separator	30224100009	1

Above data is subject to change without notice,pls reference the SP in global service website



GREE ELECTRIC APPLIANCES, INC. OF ZHUHAI

Add: West Jinji Rd, Qianshan, Zhuhai, Guangdong, China, 519070

Tel: (+86-756) 8522218 Fax: (+86-756) 8669426

E-mail: gree@gree.com.cn www.gree.com

For continuous improvement in the products, Gree reserves the right to modify the product specification and appearance in this manual without notice and without incurring any obligations.

JF00302969