



---

## ***Installation, Service & Troubleshooting***

Models:

GWH09KF-A3DNB1A

GWH12KF-A3DNB1A

GWH09KF-D3DNB1C

GWH12KF-D3DNB1C

GWH18KG-D3DNB1C

GWH24KG-D3DNB1A

# Table of Contents

Safety Precautions & Warnings.....	3
Model Number Identification.....	4
Physical & Electrical Data.....	5 - 7
Product Introduction.....	8
Refrigeration Cycles and Components.....	9 - 13
Indoor & Outdoor Components.....	14 - 15
Basic & Protection Functions.....	16 - 21
Remote Control Operation.....	22 - 25
Refrigerant Lines, Connection, Evacuating and Charging.....	26 - 29
Installation and Filter Maintenance.....	30 -35
Electrical Schematics.....	36 - 44
Outdoor Circuit Board.....	45
Troubleshooting Indoor Components.....	46 - 47
Troubleshooting Outdoor Components.....	48 - 56
Fault Codes & Status Displays.....	57 - 78
Troubleshooting Flow Charts.....	79 - 105
Disassembly of Indoor Units.....	106 - 111
Disassembly of 9,000 & 12,000 btuh Outdoor Systems.....	112 - 117
Disassembly of 18,000 and 24,000 btuh Outdoor systems.....	118 - 123
Appendix 1 - 3 Temperature Sensor Resistance Tables.....	123 - 129

# Safety Precautions & Warnings



## Warning

Installing, starting up, and servicing air conditioner can be hazardous due to system pressure, electrical components, and equipment location, etc. Only trained, qualified installers and service personnel are allowed to install, start-up, and service this equipment. Untrained personnel can perform basic maintenance functions such as cleaning coils. All other operations should be performed by trained service personnel. When handling the equipment, observe precautions in the manual and on tags, stickers, and labels attached to the equipment. Follow all safety codes. Wear safety glasses and work gloves. Keep quenching cloth and fire extinguisher nearby when brazing. Read the instructions thoroughly and follow all warnings or cautions in literature and attached to the unit. Consult local building codes and current editions of national as well as local electrical codes.

Recognize the following safety information:



**Warning:** Incorrect handling could result in personal injury or death.



**Caution:** Incorrect handling may result in minor injury, or damage to product or property.



## Caution

- Never install the unit in a place where a combustible gas might leak, or it may lead to fire or explosion.
- Make a proper provision against noise when the unit is installed at a telecommunication center or hospital.
- Provide a GFIC circuit when the local or national electric code requires it.
- Never wash the unit with water.
- Handle unit transportation with care. Use two people when the weight exceeds the capacity for one person.
- Never touch the heat exchanger fins with bare hands, sharp edges could cause personal injury.
- Never touch the compressor or refrigerant tubing without proper hand protection.
- Do not operate the unit without the air filters in place.
- Should any emergency occur, stop the unit and disconnect the electrical supply.
- Properly insulate tubing running inside the room to prevent water damage from condensation.



## Warning

All installation or repair work shall be performed by your dealer or a specialized subcontractor as there is the risk of fire, electric shock, explosion or injury



## Warning

All electrical work must be performed by a qualified, licensed electrician according to local and national codes as well as the instructions provided in the manual.

- Before installing, modifying, or servicing the system, the main electrical disconnect must be off. There may be more than one disconnect switch. Lock out and tag switch with a suitable warning label.
- Never supply power to the unit unless all wiring and tubing are completed, reconnected and checked.
- This system adopts highly dangerous electrical voltage. Incorrect connections or inadequate grounding can cause personal injury or death. Refer to your local and national codes for proper grounding.
- Have the unit properly grounded with all connections tight. Loose connections can cause overheating and a possible fire hazard.



## Warning

### Pressurized Refrigerant

Personal injury could result in failure to follow this warning. Systems contain oil and refrigerant under high pressure, proper refrigerant handling techniques should be completed by a qualified technician.



## Warning

### Live Electrical Components

Personal injury, property damage, or death could result in failure to follow this warning. Follow all electrical precautions when servicing this system, it may be necessary to service or troubleshoot with live electrical circuits. All work should be completed by a qualified technician.

# Model Number Identification

## Product Catalog Number-Nomenclature

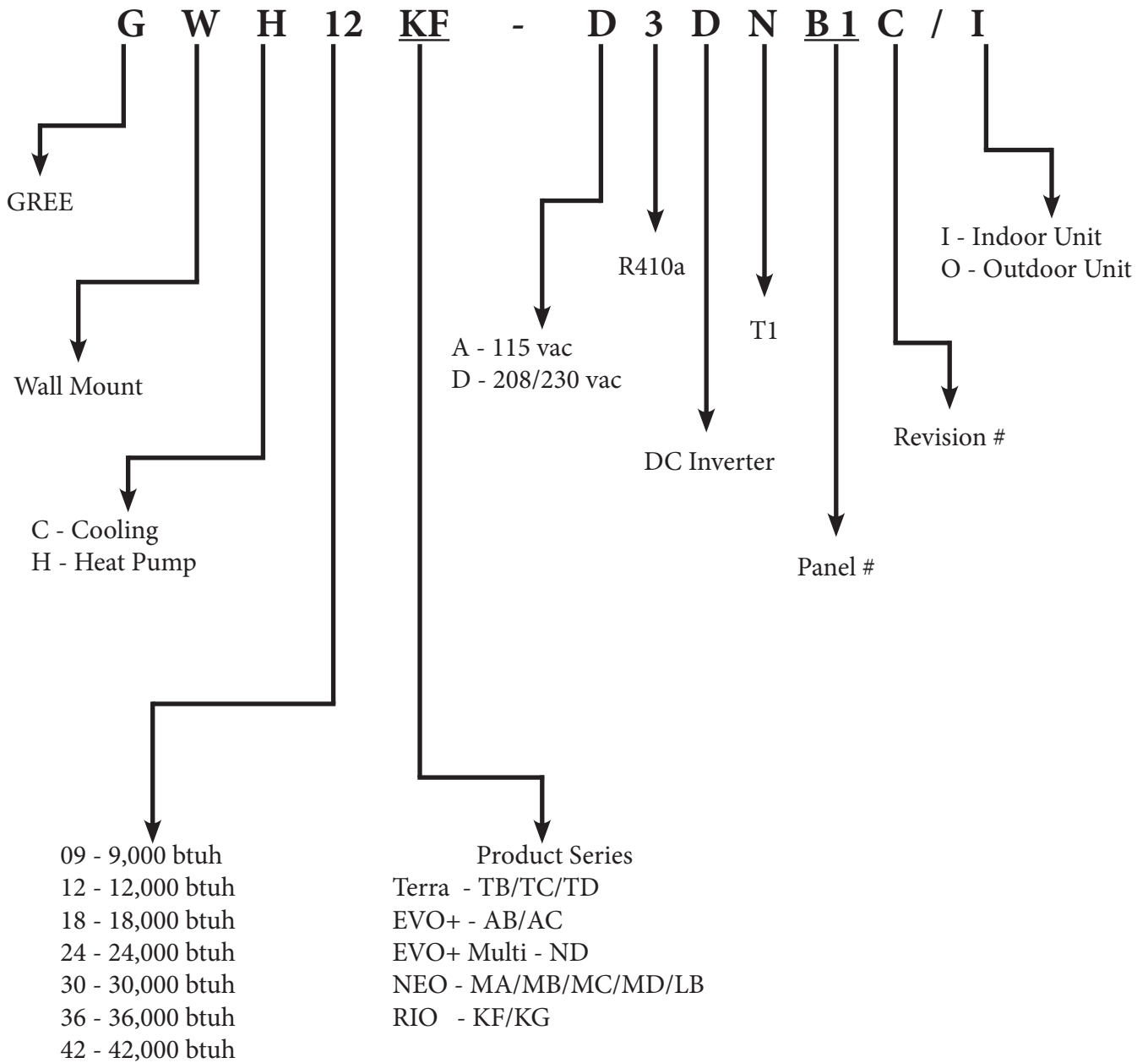

## Physical & Electrical Data, cont.

Model		GWH09KF-A3DNB1A	GWH12KF-A3DNB1A
System Type		Heat Pump	
Power Supply		115v / 60Hz	115V / 60Hz
Rated Current Cooling	Amps	9.0	15.0
Rated Current Heating	Amps	9.5	15.5
<b>System Performance</b>			
Cooling Cap (Min/Max)	Btu/h	9,000 (3,500-11,000)	11,800 (3,300-12,500)
Heating Cap (Min/Max)	Btu/h	9,800 (2,500-11,000)	13,000 (3,400-13,500)
Operating Range - Cooling	deg F	64 - 113	64 - 113
Operating Range - Heating	deg F	5 - 75	5 - 75
<b>System Specifications</b>			
Compressor Type		DC Inverter-driven Twin Rotary	
Sound Level	db	53	55
Net/Gross Weight Indoor	lb	19/25	19/25
Net/Gross Weight Outdoor	lb	69/77	69/77
Condenser Coil Type			
Refrigerant/Charge	oz	R410a /35.3	R410a / 35.3
Line Set Size Liq. - Suction		1/4" - 3/8"	1/4" - 3/8"
Pre-Charged Lineset Ft.	Feet	25	25
Additional Refrigerant charge/additional feet	oz	0.2	0.2
Max. Total Piping Length	Feet	49	66
Max. Elevation	Feet	33	33
MCA	Amps	13	15
MOCP/Breaker Size	Amps	20	25
Wire Size to Outdoor Unit, # of Wires per Local Code	awg	14*	12*
Wire Size and # of Conductors from Indoor to Outdoor unit		14awg/4c*	

\*Comply with National Electric Code or Local Electric Code in selecting proper wire and circuit breaker size. National Code or Local Code, should supersede wire sizes above.

Note: The manufacturer reserves the right to modify the design and/or change the specifications without notice. Please refer to specific installation manual for current information.

## Physical & Electrical Data, cont.

Model		GWH09KF-D3DNB1C	GWH12KF-D3DNB1C
System Type		Heat Pump	
Power Supply		208-230v / 60Hz	208-230V / 60Hz
Rated Current Cooling	Amps	3.9	5.4
Rated Current Heating	Amps	3.4	4.7
<b>System Performance</b>			
Cooling Cap (Min/Max)	Btu/h	9,000 (3,800-11,500)	12,000 (3,300-12,500)
Heating Cap (Min/Max)	Btu/h	9,000 (3,300-11,500)	12,000 (3,400-12,500)
Operating Range - Cooling	deg F	5 - 109	5 - 109
Operating Range - Heating	deg F	5 - 75	5 - 75
<b>System Specifications</b>			
Compressor Type		DC Inverter-driven Twin Rotary	
Sound Level	db	49	52
Net/Gross Weight Indoor	lb	19/25	20/27
Net/Gross Weight Outdoor	lb	64/73	68/77
Condenser Coil Type			
Refrigerant/Charge	oz	R410a / 26.1	R410a / 35.3
Line Set Size Liq. - Suction		1/4" - 3/8"	1/4" - 3/8"
Pre-Charged Lineset Ft.	Feet	25	25
Additional Refrigerant charge/additional feet	oz	0.2	0.2
Max. Total Piping Length	Feet	66	66
Max. Elevation	Feet	33	33
MCA	Amps	10	10
MOCP/Breaker Size	Amps	15	15
Wire Size to Outdoor Unit, # of Wires per Local Code	awg	14*	14*
Wire Size and # of Conductors from Indoor to Outdoor unit		14awg/4c*	

\*Comply with National Electric Code or Local Electric Code in selecting proper wire and circuit breaker size. National Code or Local Code, should supersede wire sizes above.

Note: The manufacturer reserves the right to modify the design and/or change the specifications without notice. Please refer to specific installation manual for current information.

## Physical & Electrical Data, cont.

Model		GWH18KG-D3DNB1C	GWH24KG-D3DNB1A
System Type		Heat Pump	
Power Supply		208-230v / 60Hz	208-230V / 60Hz
Rated Current Cooling	Amps	7.9	11.5
Rated Current Heating	Amps	11.8	13.0
<b>System Performance</b>			
Cooling Cap (Min/Max)	Btu/h	18,000 (4,500-21,000)	22,000 (6,400-24,000)
Heating Cap (Min/Max)	Btu/h	23,000 (4,000-23000)	26,600 (4,100-26,600)
Operating Range - Cooling	deg F	5 - 109	5 - 109
Operating Range - Heating	deg F	5 - 75	5 - 75
<b>System Specifications</b>			
Compressor Type		DC Inverter-driven Twin Rotary	
Sound Level	db	56	53
Net/Gross Weight Indoor	lb	27/35	33/44
Net/Gross Weight Outdoor	lb	99 / 110	132 / 146
Condenser Coil Type			
Refrigerant/Charge	oz	R410a / 45.9	R410a / 54.7
Line Set Size Liq. - Suction		1/4" - 1/2"	1/4" - 1/2"
Pre-Charged Lineset Ft.	Feet	25	25
Additional Refrigerant charge/additional feet	oz	0.2	0.2
Max. Total Piping Length	Feet	82	82
Max. Elevation	Feet	33	33
MCA	Amps	15	16
MOCP/Breaker Size	Amps	25	25
Wire Size to Outdoor Unit, # of Wires per Local Code	awg	14*	14*
Wire Size and # of Conductors from Indoor to Outdoor unit		14awg/4c*	

\*Comply with National Electric Code or Local Electric Code in selecting proper wire and circuit breaker size. National Code or Local Code, should supersede wire sizes above.

Note: The manufacturer reserves the right to modify the design and/or change the specifications without notice. Please refer to specific installation manual for current information.

# Product Introduction

## System Overview

The RIO Ductless split heat pumps are single zone units available in size from 9000 btuh to 24,000 btuh providing heating and cooling. All comfort settings are controlled by a remote control. The RIO unit has many features to enhance comfort and efficiency. The operation of these features will be explained later in this service manual.

Superior inverter technology is used to control capacity while maintaining maximum efficiency. The RIO systems are equipped with G10 inverter technology providing precise control over the compressor frequency based on operating pressures and temperatures. Should an abnormal condition occur, the software will adjust the compressor frequency or shut down the system indicating the appropriate fault.

The indoor unit contains a digital display, which will indicate the current fault. The evaporator, swing motors, fan motors and circuit board are also components of the indoor unit. The indoor units have a on/off switch to bypass the remote control if lost or batteries fail. This will be explained later in this service manual.

The systems require R410A and are pre-charged for 25' of lineset. Please refer to your installation manual for additional charge for linesets longer than 25'.

The maximum allowable line lift and distances vary by model, please refer to the charts in the manual for proper lineset applications.

The systems use a PVE oil and should require no additional oil. All RIO units utilize an Oil Return Mode which will return oil to the compressor should the need arise.

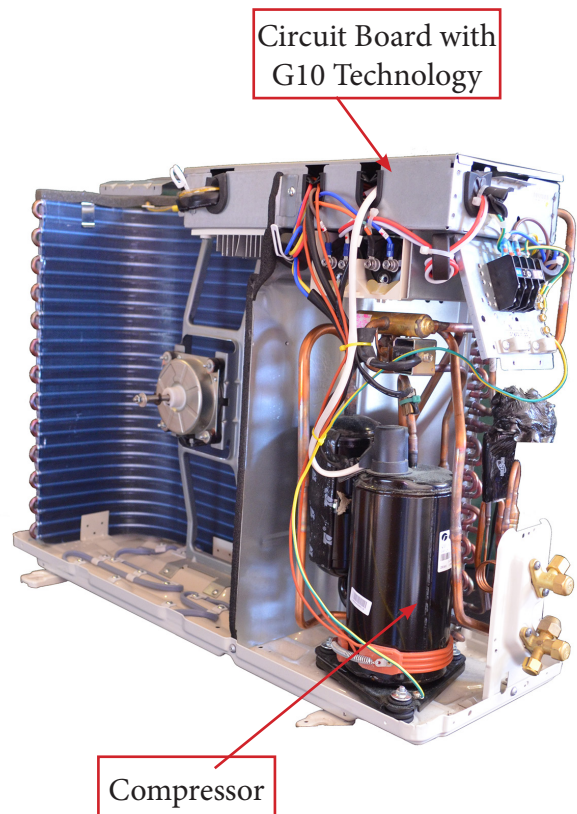
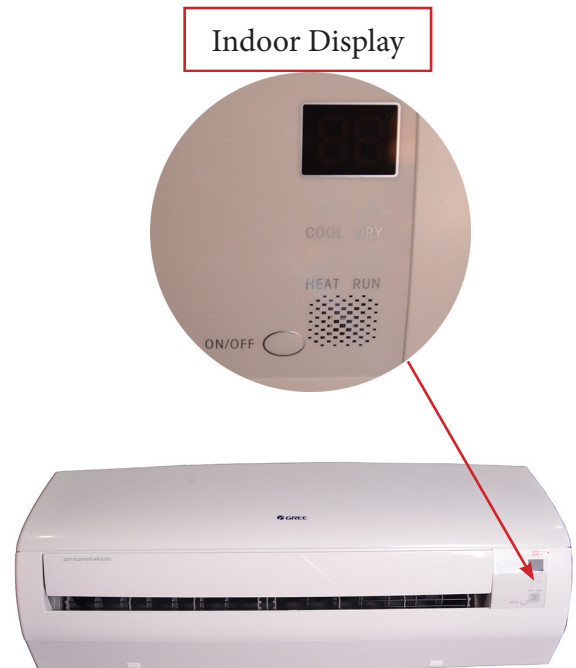



# Refrigeration Cycles and Components

## Refrigeration Components

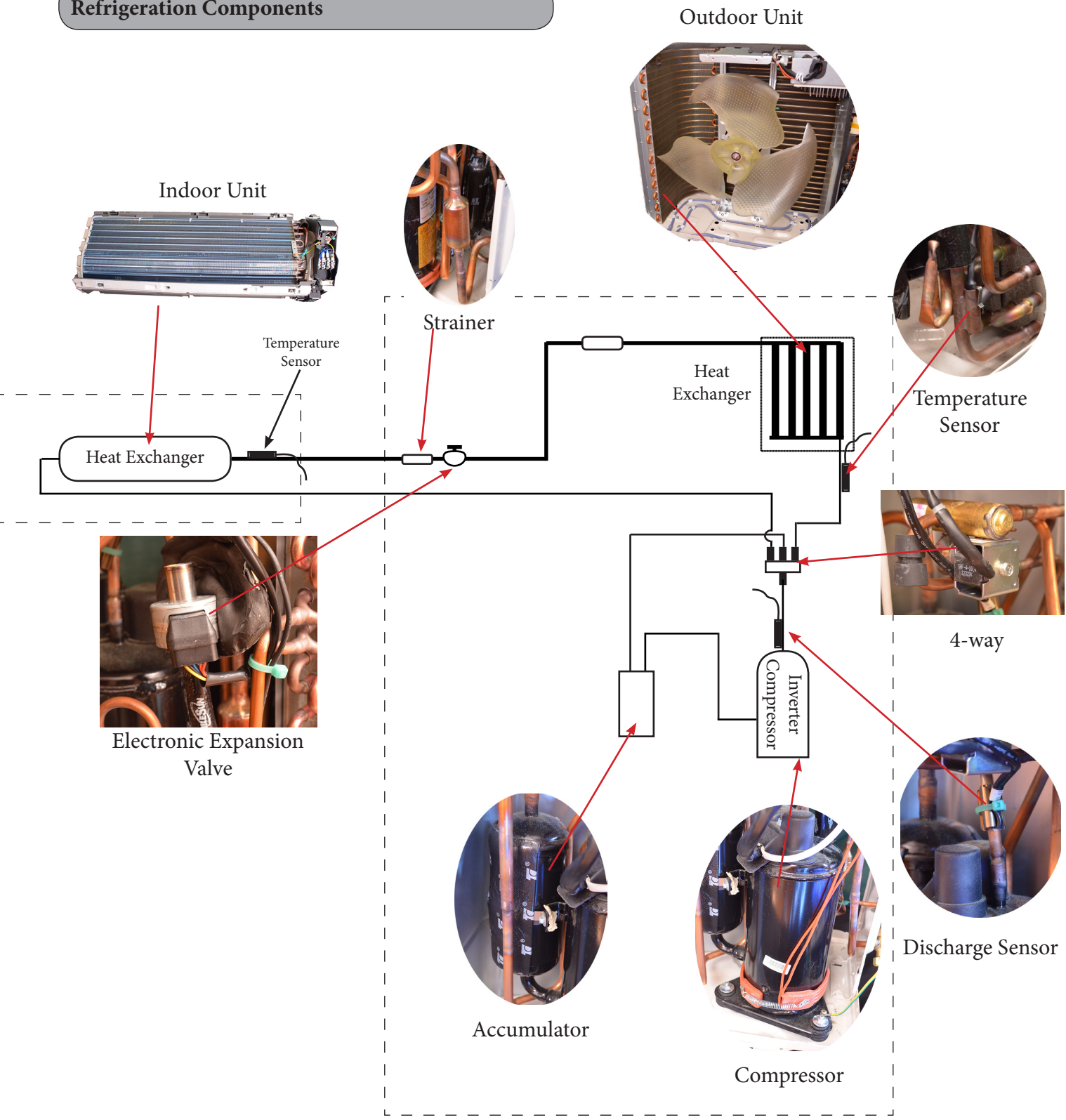

Note:  
Component locations may vary depending on models.

# Refrigeration Cycles and Components

## Cooling Mode

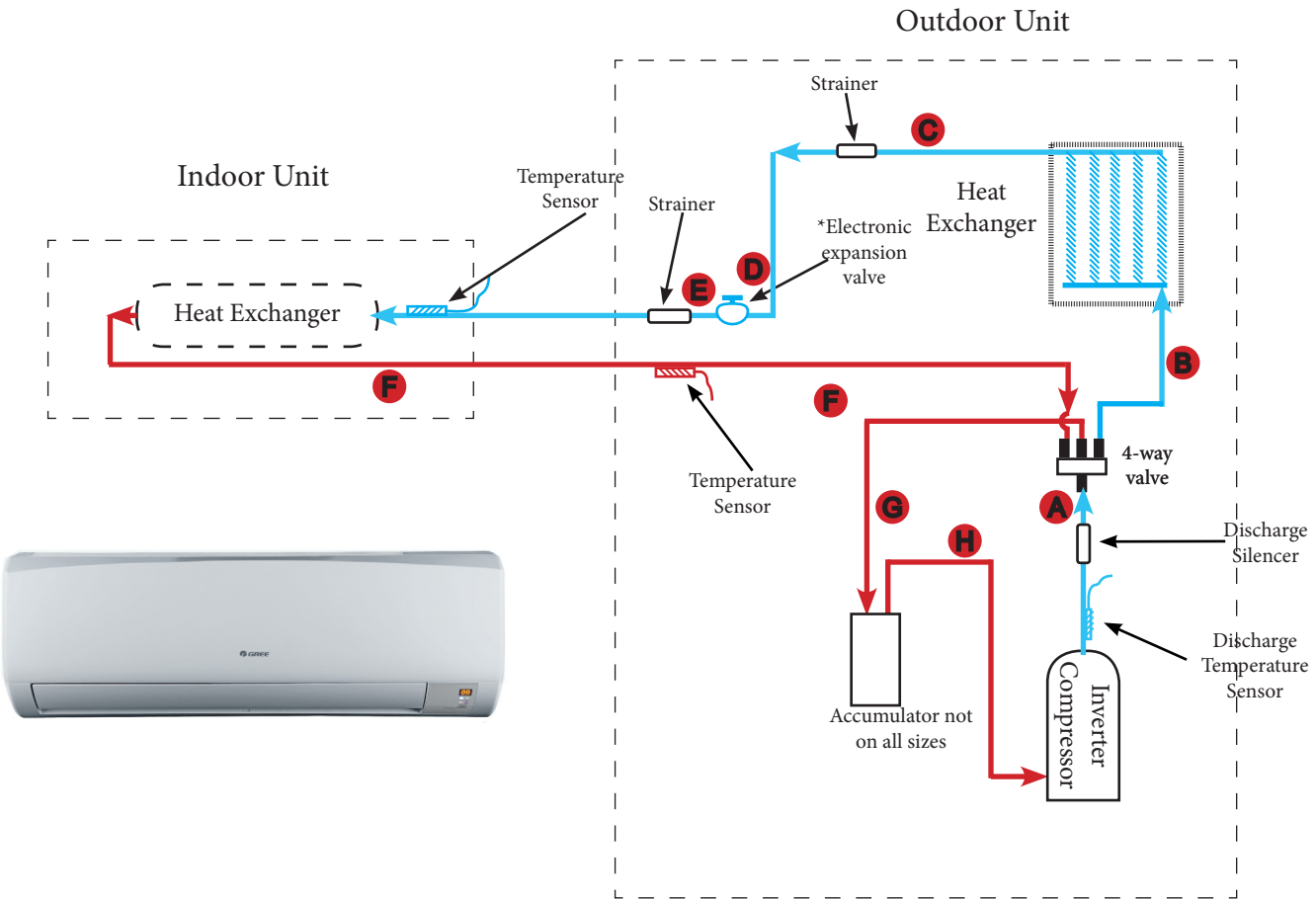

# Refrigeration Cycles and Components

## Cooling Mode

- A. Hot gas is discharged from the compressor. The temperature of the gas is monitored by the Discharge Temperature sensor and sent to the outdoor control panel.
- B. The hot gas is directed through the 4-way valve, then enters the outdoor coil. The hot gas will be slightly subcooled, however there are no pressure ports to take measurements.
- C. The subcooled liquid will enter the filter to remove contaminants.
- D. The subcooled liquid will enter the metering device and regulate the superheat level. The adjustment process and compressor speed are controlled by the outdoor circuit board.
- E. The refrigerant leaving the metering device will be in a low pressure/temperature saturated state. This cold saturated refrigerant will move through the coil absorbing heat. This liquid will flash to a vapor and will be superheated to about 10 degrees F. Since this tubing is cold, it must be insulated.
- F. The superheated vapor will be returned to the outdoor unit's 4-way valve.
- G. The refrigerant will flow to the accumulator (not all models will have an accumulator) where liquid and vapor are separated.
- H. The refrigerant will flow to the compressor and complete another refrigeration cycle.

The control board will monitor the temperature and pressures and adjust the frequency of the compressor. There are no pressure charts to evaluate temperature or pressures.

# Refrigeration Cycles and Components

## Heating Mode

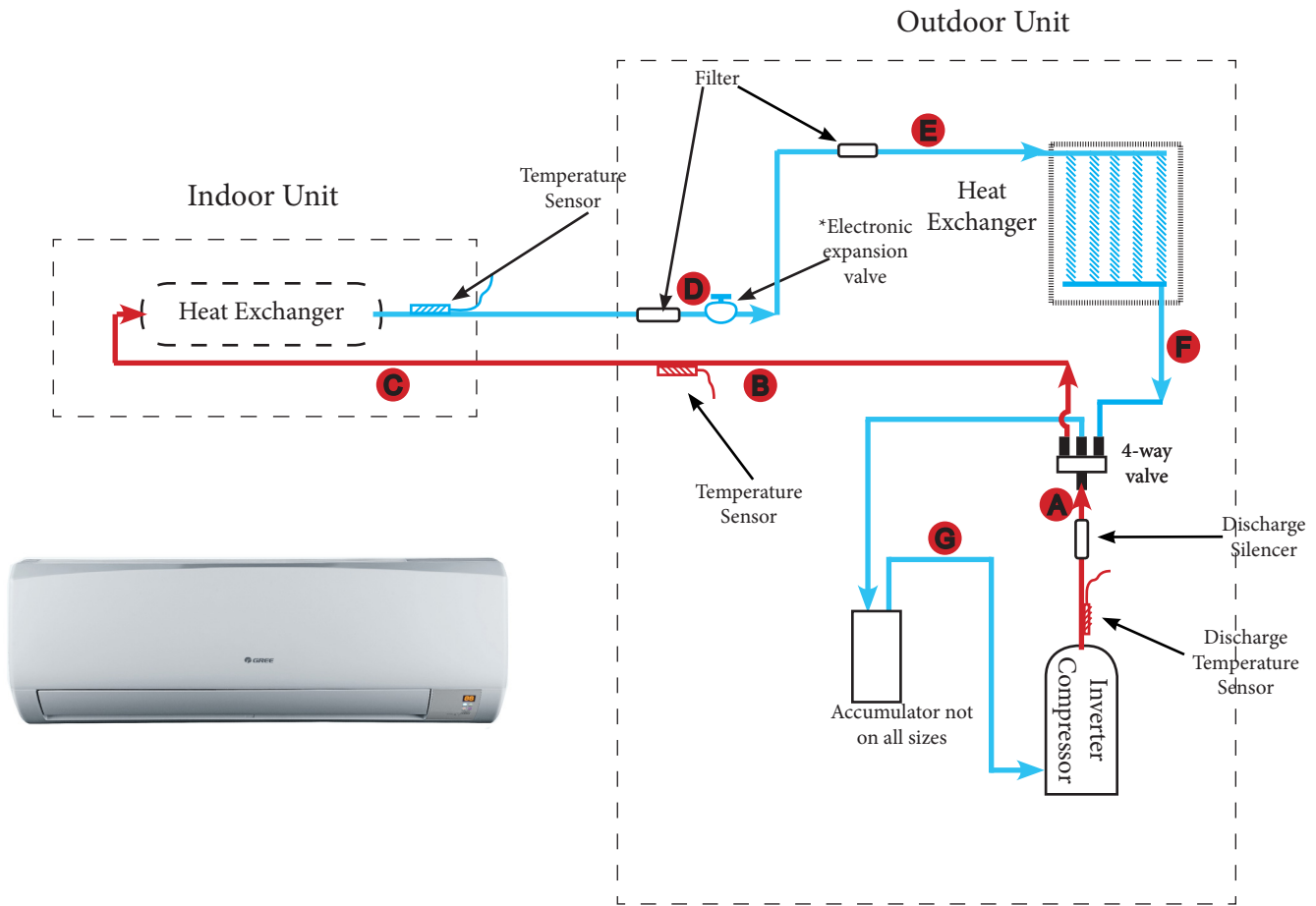

# Refrigeration Cycles and Components

## Heating Mode

- A. Hot gas is discharged from the compressor. The temperature of the gas is monitored by the Discharge Temperature sensor and sent to the outdoor control panel.
- B. The hot gas is directed through the 4-way valve to the appropriate indoor coil making the line a hot gas line.
- C. The hot gas will enter the indoor coil and condense to a saturated mix as it travel through the coil and will be slightly subcooled.
- D. The refrigerant returns to the outdoor unit through the filter, then through the metering device reducing the refrigerant to a low pressure liquid and will maintain the proper superheat.
- E. The cold refrigerant will travel through the outdoor coil (evaporator) and will pickup heat from the outdoor air. This will cause the cold saturated refrigerant to flash to a saturated mixture which will be superheated to 10 degrees F.
- F. The superheated vapor will travel through the 4-way valve to the accumulator which will prevent liquid floodback.
- G. The superheated gas will enter the compressor for another refrigeration cycle.

The control board will monitor the temperature and pressures and adjust the frequency of the compressor. There are no pressure charts to evaluate temperature or pressures.

# Indoor Unit Components

## Indoor Unit Components

RIO 12,000 btuh model

Other RIO models may vary slightly.

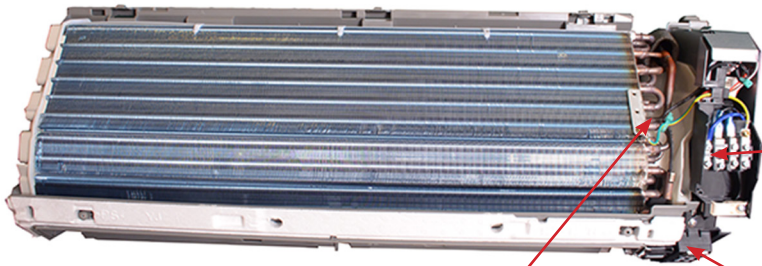

Indoor Circuit Board

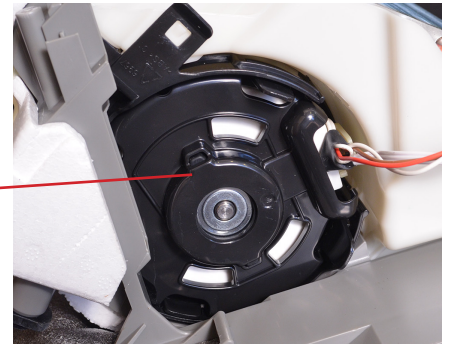

Fan Motor

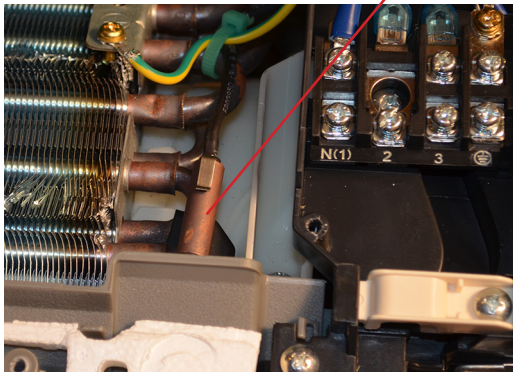

Indoor Tube Thermistor

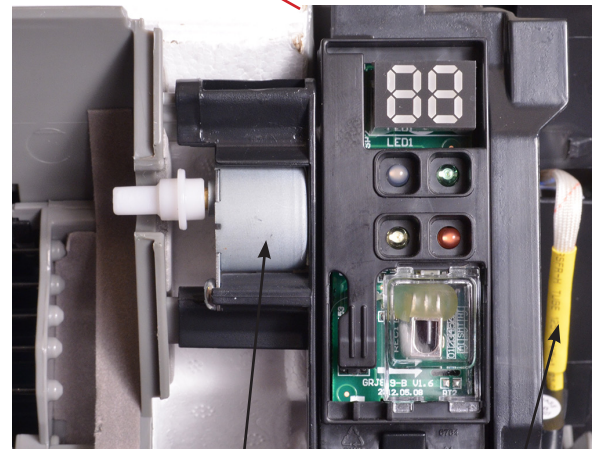

Swing Motor

Ambient Temperature Sensor

Note:  
Component locations may vary depending on models.

# Outdoor Unit Components

## Outdoor Unit Components

RIO 12,000 btuh Outdoor Unit  
Other RIO models may vary slightly.

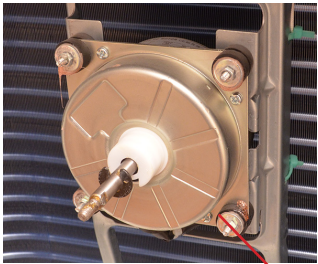

Outdoor Fan

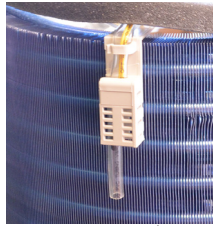

Outdoor Sensor, (mounted on outside of coil)

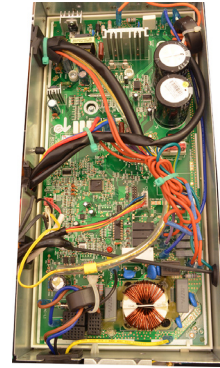

API Board

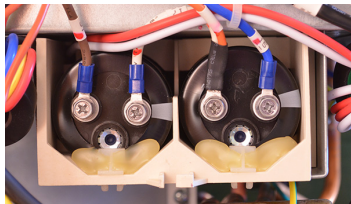

Capacitors

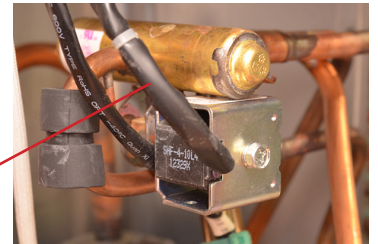

4-Way Valve

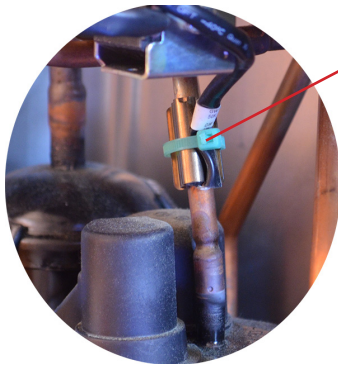

Exhaust Temp Sensor

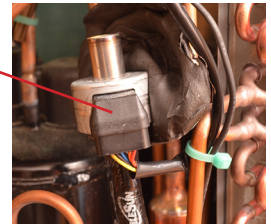

Expansion Valve

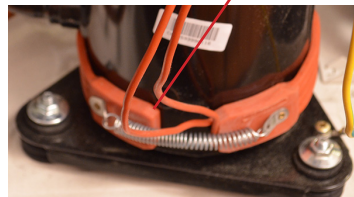

Crankcase Heater



Outdoor Tube Sensor

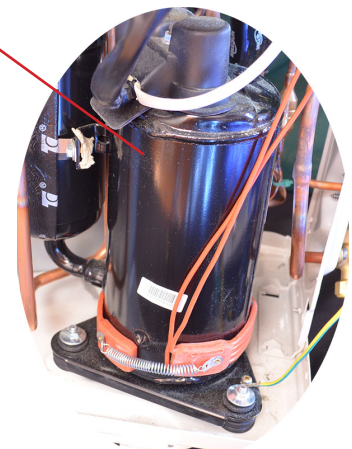

Compressor

Note:  
Component locations may vary depending on models.

# Basic & Protection Functions

## Basic Functions

The compressor should stay off for at least 3 minutes before starting the unit. The compressor circuit has a 3 minute delay if the compressor is de-energized during a run cycle. If the compressor starts from a de-energized cycle, there will be no time delay. The compressor has a minimum runtime of 6 minutes regardless of room temperature.

## 1) Cooling Mode

### Cooling Process

When the indoor ambient rises  $4^{\circ}$  F above the preset temperature from a stopped state, the unit will start the cooling cycle. The outdoor fan and compressor will start. The indoor fan will run continuously at the selected speed. The outdoor unit will monitor the appropriate temperatures and pressure and adjust the compressor speed and the EEV as required. If the indoor ambient is  $> 4^{\circ}$  F than the preset temperature, the compressor will increase the frequency;  $< 4^{\circ}$  F the compressor will begin reducing the frequency. The EEV will be closed on indoor units with no cooling requirement. The G10 technology will control compressor speed based on indoor load and compressor amperage. When the indoor temperature is satisfied, the compressor will stop, then 30 seconds later the outdoor fan will stop. When the cooling mode transfers to heating mode, the 4-way valve will be energized after a two minute compressor delay.

### Evaporator Freeze Protection

The software will monitor the indoor evaporator coil form freezing.

The following will occur 6 minutes after the compressor has been operating in the cooling or dry mode:

If the evaporator temperature drops below  $36^{\circ}$  F, the compressor will operate at a reduced frequency. If the evaporator is below  $30^{\circ}$  F for 3 minutes, the compressor will stop, 30 seconds later the outdoor fan will stop. In cooling mode, the indoor fan and swing motor will remain on. If the evaporator temperature is  $\geq 50^{\circ}$  F and the compressor is off for at least 3 minutes, the compressor will resume its normal operation state.

### Overcurrent Protection

The software will monitor the compressor current to maintain it in a safety and reliable operating range.

If the total current is greater than the rating, the compressor will stop; the outdoor fan will continue to run for 30 seconds, then stop.

## 2) Dry Mode

### Drying Process

This feature will not take the place of a dehumidifier, it is intended to dry the filter and slightly cool the air. If the indoor ambient temperature is greater than the preset temperature, the unit will enter the cooling and drying mode, in which case the compressor will operate and the indoor fan will run at a low speed. When the indoor ambient temperature is at or below the preset temperature, the unit will operate in its previous running state. When the indoor ambient drops to more than  $4^{\circ}$  F below the preset temperature the compressor will stop running, then 30 seconds later the outdoor fan will stop, the indoor fan will run at low speed.

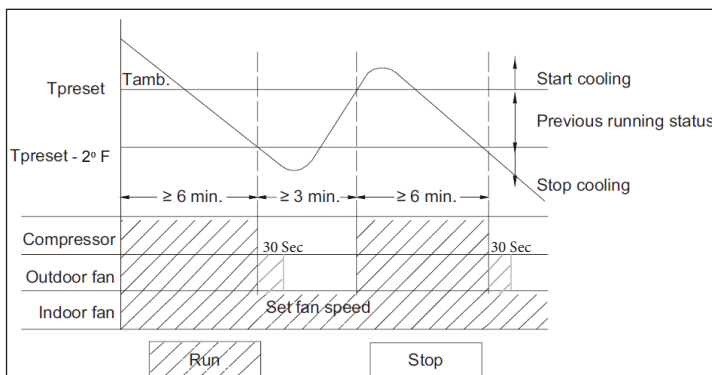



# Basic & Protection Functions

## Basic Functions

### 3) Heating Mode

#### Heating Process

When the indoor ambient drops 4° F below the preset temperature, the unit will start the heating cycle. The outdoor fan, compressor and 4-way valve will operate. The indoor fan will operate in the “Cold Air Prevention” mode in which the indoor fan will have a 2 minute delay after the call for heating. The indoor evaporator coil temperature must reach 104° F before the indoor fan will start, this will prevent cold air from discharging from the indoor coil. When the indoor evaporator coil temperature is > 104° F, the indoor fan will operate at low speed for 1 minute. With 1 minute of operation or 2 minutes of no fan operation and the indoor evaporator coil temperature is > 108° F, the indoor fan will operate at its preset condition.

If the indoor ambient temperature is < 9° F and > 2° F of the preset temperature, the unit will run in its original mode of operation.

If the compressor is running and the mode is changed from heating to cooling, the compressor will stop, the 4-way valve will be de-energized 2 minutes later, the outdoor fan will stop after a 1 minute delay.

If the indoor ambient temperature is  $\geq 9^\circ$  F than the preset temperature, the compressor will stop and the outdoor fan will stop after a 30 second delay. The indoor fan will continue to operate at its preset mode.

The G10 technology will determine compressor frequency based on ambient temperatures.

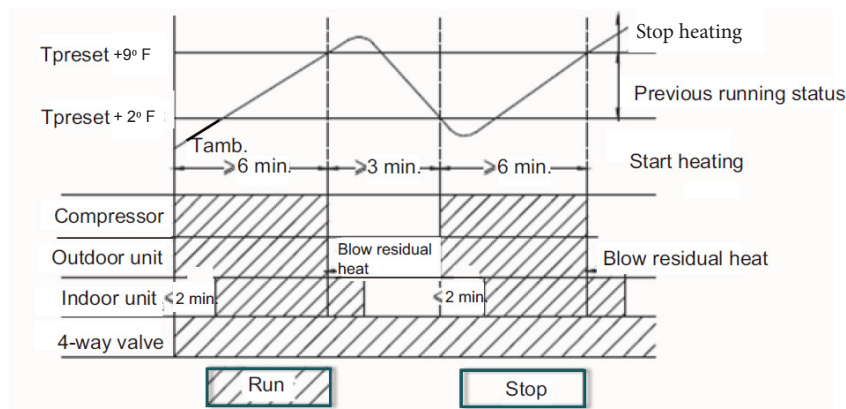

# Basic & Protection Functions

## Basic Functions

### Defrost Process

*You may force a defrost in heat mode by pressing the “+” and “-” buttons alternately three times within 5 seconds.*

- 1) The unit will enter defrost when the following conditions are met:
  - A. Outdoor ambient  $\leq 41^{\circ}$  F
  - B. Compressor had accumulated more than 3 hours of operation in heating mode
  - C. The outdoor coil  $\leq 32^{\circ}$  F

Note: The compressor runtime will be cleared when the outdoor ambient is  $> 41^{\circ}$  F or when the compressor has started up after changing to cooling or drying mode and defrost has finished. The runtime will not be cleared when the unit has stopped after reaching the setpoint temperature, a protection fault or changing to fan mode.

There are 3 perimeters used in the defrost algorithms, Outdoor ambient ( $T_{\text{outdoorambient}}$ ), Outdoor tube ( $T_{\text{outdoortube}}$ ) and a calculated  $T_{\text{compensation}}$

$T_{\text{compensation}}$  is calculated by the following:

- D. After power-up, for the first defrost  $T_{\text{compensation}} = 32^{\circ}$  F
- E.  $T_{\text{outdoortube}} > 36^{\circ}$  F then  $T_{\text{compensation}} = 32^{\circ}$  F
- F.  $T_{\text{outdoortube}} \leq 36^{\circ}$  F then  $T_{\text{compensation}} = 37^{\circ}$  F

- 2) When heating has operated continuously for 45 minutes, or accumulated for 90 minutes, the unit will enter defrost mode in 3 minutes after meeting any of the conditions below:

- A. Outdoor ambient  $\geq 41^{\circ}$  F and outdoor coil  $\leq 28^{\circ}$  F
- B.  $28^{\circ}$  F  $\leq T_{\text{outdoorambient}} < 41^{\circ}$  F, “ $T_{\text{outdoortube}} - T_{\text{compensation}} \leq 21^{\circ}$ F”
- C.  $23^{\circ}$  F  $\leq T_{\text{outdoorambient}} < 28^{\circ}$  F  $\leq T_{\text{outdoortube}} - T_{\text{compensation}} \leq 18^{\circ}$ F”
- D.  $14^{\circ}$  F  $\leq T_{\text{outdoorambient}} < 23^{\circ}$  F,  $T_{\text{outdoortube}} - T_{\text{compensation}} \leq (T_{\text{outdoorambient}} - 37^{\circ}$  F)
- E.  $T_{\text{outdoorambient}} < 14^{\circ}$  F,  $T_{\text{outdoortube}} - T_{\text{compensation}} \leq (T_{\text{outdoorambient}} - 37^{\circ}$  F)

3) During defrost, if run time for the compressor does not reach 3 minutes, the defrost cycle will not start for the next 2 hours. At that time the compressor stops operation and 30 seconds later the outdoor fan will stop. 30 seconds after this the 4-way reversing valves will de-energized. Following another 30 second delay, the compressor will increase its compressor speed for defrosting. Defrosting will last for 450 seconds or until the  $T_{\text{outdoortube}} \geq 50^{\circ}$  F, at this temperature the compressor will decrease its compressor speed for 30 seconds, then will stop. In another 30 seconds the 4-way valve will energize, the 60 seconds later the compressor and outdoor fan will start. The compressor speed for defrosting will be 85hz. During Defrost mode, a “H1” will be displayed on the indoor front panel display indicating the user selected mode has been overridden and the system is performing a outdoor coil defrost operation.

#### 4) Defrost Sequence:

When a defrost condition has been met, the compressor will stop, all expansions valves will open fully, the outdoor fan will stop 40 seconds after the compressor stops. The 4-way valve will reverse direction (cooling mode), then the compressor will start and enter the defrost frequency. The control, board along with ambient sensors will calculate defrost time.

#### 5) Oil Return:

Oil return condition can be met if the unit operates at a low frequency for an extended time. The indoor display will indicate “H1” for this condition and is a normal procedure.

# Basic & Protection Functions

## Basic Functions

### **Cold Air Prevention (Heating mode with compressor running)**

*The system guards against discharging cold air in heating mode. It will delay the indoor fan until the evaporator coil has warmed up to discharge warm, comfortable air into the room.*

1) When the  $T_{\text{indoor,ambient}} < 75^{\circ}\text{F}$  and the  $T_{\text{indoor,tube}} \leq 104^{\circ}\text{F}$  with the fan in a stopped state, the indoor fan will begin to run at low speed after a 2 minute delay. This will reduce cold air upon heating startup. Within 2 minutes, if  $T_{\text{indoor,tube}} > 104^{\circ}\text{F}$ , the indoor fan will run at low speed. After 1 minute of operation, the fan will run at the preset fan mode. Within 1 minute of low speed operation or 2 minutes of no fan operation, with the  $T_{\text{indoor,tube}} > 108^{\circ}\text{F}$ , the fan will run at the preset mode.

2) If the  $T_{\text{indoor,ambient}} \geq 75^{\circ}\text{F}$  and the  $T_{\text{indoor,tube}} \leq 108^{\circ}\text{F}$  the indoor fan will run at low speed for 1 minute than run at the preset mode. After 1 minute of low speed operation, if the and the  $T_{\text{indoor,tube}} > 108^{\circ}\text{F}$  the fan will operate at its preset mode.

Note:

The  $T_{\text{indoor,ambient}}$  in 1 & 2 above refers to the unit going into the heating mode coming out of defrost.

### **Overcurrent and Speed Protection (Total Current = $I_{\text{total}}$ )**

*The software will monitor the compressor current draw and adjust the compressor speed in order to maintain the inverter and compressor in a safety and reliable operating range.*

- A. If  $I_{\text{total}} \leq 13\text{a}$ , an increase in frequency will be allowed
- B. If  $I_{\text{total}} \geq 15\text{a}$ , increasing the frequency is not allowed.
- C. If  $I_{\text{total}} \geq 17\text{a}$ , the compressor will decrease its frequency
- D. If  $I_{\text{total}} \geq 19\text{a}$ , the compressor will stop and the indoor fan will stop after 30 seconds.

## **4) Fan Mode**

Under this mode, the fan will run at the preset speed and the outdoor fan, compressor and 4-way valve will stop.

## **5) Auto Mode**

### **Auto Mode Process**

Setting the auto mode will run the unit in heat or cool automatically depending on  $T_{\text{indoor,ambient}}$

#### 1) Operating Parameters

- A. If the  $T_{\text{indoor,ambient}} \geq 79^{\circ}\text{F}$  the unit will operate in cooling mode. The set temperature is  $77^{\circ}\text{F}$ .
- B. If the  $T_{\text{indoor,ambient}} \leq 72^{\circ}\text{F}$  the unit will operate in heat mode. The set temperature is  $68^{\circ}\text{F}$ .
- C. When the  $T_{\text{indoor,ambient}} \leq 73^{\circ}\text{F}$  and  $\geq 77^{\circ}\text{F}$ , the unit will operate in the previous state. If it is energized for the first time, it will run in Fan mode
- D. In auto mode, the cooling frequency will be the same as the cooling only mode and the heating frequency will be the same as the heating only mode.

#### 2) Protection

- A. In cooling operation, protection is the same as the cooling only mode
- B. In heating operation, protection is the same as the heating only mode
- C. When the indoor ambient temperature changes, the operation mode will be automatically selected. Once started the compressor will have a 6 minute runtime.

# Basic & Protection Functions

## Protection Functions

### Common Protection Functions and Fault Displays

#### Coil High Temperature Protection

$T_{\text{tube}}$  = measured temperature of outdoor coil in cooling mode, measured temperature of indoor coil in heating mode.

**1) Outdoor Coil High Temperature Protection** - *In cooling mode the software will monitor the outdoor coil for an abnormal high temperature condition.*

- A. If  $T_{\text{tube}} \leq 126^{\circ} \text{F}$ , the unit will return to its original operation state
- B. If  $T_{\text{tube}} \geq 131^{\circ} \text{F}$ , frequency rise is not allowed
- C. If  $T_{\text{tube}} \geq 136^{\circ} \text{F}$ , the compressor will run at reduced frequency
- D. If  $T_{\text{tube}} \geq 144^{\circ} \text{F}$ , the compressor will stop and the indoor fan will operate at preset speed

**2) Indoor Coil Temperature Protection** - *In heating mode the software will monitor the indoor coil for an abnormal high temperature condition.*

- A. If  $T_{\text{tube}} \leq 122^{\circ} \text{F}$ , the unit will return to its original operation state
- B. If  $T_{\text{tube}} \geq 127^{\circ} \text{F}$ , frequency rise is not allowed
- C. If  $T_{\text{tube}} \geq 133^{\circ} \text{F}$ , the compressor will run at reduced frequency
- D. If  $T_{\text{tube}} \geq 140^{\circ} \text{F}$ , the compressor will stop and the indoor fan will blow residual heat and then stop

#### 3) Compressor Discharge Temperature Protection

*The software will monitor the compressor discharge for an abnormal high temperature condition.*

- A. If  $T_{\text{tube}} \geq 208^{\circ} \text{F}$ , frequency rise is not allowed
- B. If  $T_{\text{tube}} \geq 217^{\circ} \text{F}$ , the compressor will run at reduced frequency
- C. If  $T_{\text{tube}} \geq 230^{\circ} \text{F}$ , the compressor will stop
- D. If  $T_{\text{tube}} \leq 194^{\circ} \text{F}$  and the compressor has been off for at least 3 minutes, the compressor will resume operation

#### 4) Compressor High Pressure Protection (Not available on 115v 9k & 12k models)

When the high pressure switch is detected for 6 seconds or more, the compressor will stop and can only be started by powering off the unit. Dirty coils, refrigerant overcharge and outdoor fan problems can cause this fault.

#### 5) Compressor Phase-lacking Protection

If one of the compressor phases are detected open before startup, the compressor will enter phase-locking protection. The malfunction will be cleared after 1 min, then the unit will try a restart. If an error has been detected for 6 times continuously, the compressor will lock out and will need to have power cycled. The errors will be cleared after the compressor has run for 7 minutes continuously.

#### 6) Module Protection (IPM)

Under module protection mode, the compressor will stop. When the compressor remains off for 3 minutes, the compressor will resume operation. If the module protection occurs six times in succession, the compressor will remain off. Power will need to be cycled to start unit. This is a thermal protection for the indoor module.

#### 7) DC Buss Voltage Protection

*The software will monitor the DC bus voltage.*

If voltage on the DC Bus is below 150 or over 420v, the compressor will stop and the outdoor fan will stop in 30 seconds. When the voltage on the DC bus returns to normal and the compressor has been off for 3 minutes, the compressor will resume its operation.

# Basic & Protection Functions

## Protection Functions

### **8) Communication Fault**

If the unit fails to receive correct signals for a 3 minutes, communication fault will occur and the whole system will stop and a “E6” will be displayed on the front panel of the indoor unit.

# Remote Control Operation

## Remote Buttons



### Note:

This remote control is used in other models and some features may or may not be available. Consult the owners manual for specific features for your model. There should be no obstructions between the remote control and the indoor unit for proper operation. Keep the remote from direct sunlight or any source that generates heat, keep clean and dry. Change batteries frequently.

### Note:

For detailed explanation of the functions, refer to the “Other Controls” section of this manual for your model.

### Button Identification

The function and operation of each button will be explained later in this manual under Product Functions.

1. On/Off button
2. Mode, press to select desired operation
3. Decrease temperature
4. Increase temperature
5. Fan, press to select fan speed
6. Swing angle button (up & down)
7. Health/Save button, not available on all models
8. Swing angle button (left & right)
9. X-Fan button
10. Temperature Display
11. Timer Button
12. Turbo Fan Button
13. Sleep Button
14. Light Button

Press “mode” and “-” buttons to switch between Fahrenheit & Centigrade

Press “-” & “+” to lock control

# Remote Control Operation

## Display Icons

- 15. Mode icons
- 16. Lock icon
- 17. Light icon
- 18. Sleep icon
- 19. Temperature icon
- 20. Up & down swing icon
- 21. Left & right swing icon
- 22. Set time icon
- 23. Digital display
- 24. Fan speed icon

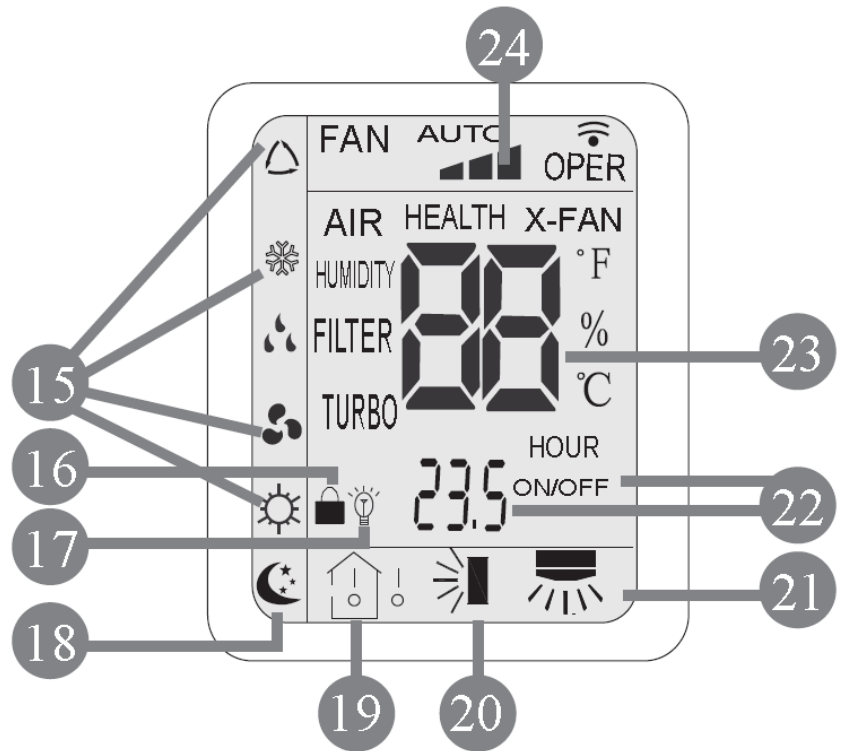

## Replacing Batteries:

1. Locate the battery cover on the back of the remote.
2. Slide the cover downward.
3. Make sketch of battery polarities, then replace with two "AAA" batteries.
4. Replace cover.

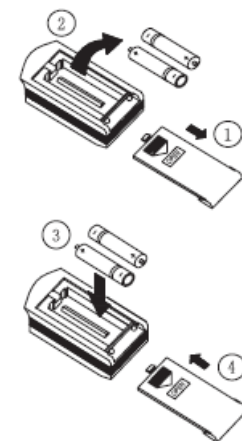

# Product Introduction

## Remote Control Functions

### 1) On/Off

The on-off state will change with each button press.

### 2) Mode Setting

Each time you press this button, a mode is selected in a sequence that goes from AUTO, COOL, DRY, FAN, and HEAT

After energization, AUTO mode is defaulted. In AUTO mode, the set temperature will not be displayed on the LCD, and the unit will automatically select the suitable operation mode in accordance with the room temperature to make indoor room comfortable.

### 3) "-" Button

Press this button to decrease set temperature. Hold it down for above 2 seconds to rapidly decrease set temperature. In AUTO mode, set temperature is not adjustable.





### 4) "+" Button

Press this button to increase set temperature. Hold it down for above 2 seconds to rapidly increase set temperature. In AUTO mode, set temperature is not adjustable.

### 5) Fan

This button is used for setting fan speed in the sequence that goes from AUTO, low, medium, high, then back to auto.

### 6) Up & Down Swing

Press  button to start or stop up & down swing function. The remote controller defaults to simple swing condition. Press + button and  button at the same time at unit OFF to switch between simple swing and static swing;  blinks for 2 seconds. In static swing condition, pressing  button, the swing angle up & down louver positions. If the unit is turned off during swing operation, the louver will stop at present position.

### 7) Health|Save

Press HEALTH part of this button to turn on or off HEALTH function. (only for some model)

Pressing SAVE this button, SE is displayed and the unit goes into SAVE operation mode. Press SAVE button again to cancel SAVE function. During SAVE operation, the temperature and fan speed is not adjustable.

### 8) Left & Right Swing

Press  button to start or stop left & right swing function. The remote controller defaults to a simple swing position.

Press + button and  button at the same time at unit OFF to switch between simple swing and static swing;  blinks for two seconds

In static swing position, pressing  button the swing angle will change positions.



# Product Introduction

## Remote Control Functions

### 9) X-Fan

Allows fan to run after cooling cycle to dry off the coil and inhibit the growth of bacteria and mildew. Works with “Auto” mode.

### 10)Temp Button

Toggles the display between set temperature, indoor temperature and outdoor temperature.

### 11) Timer On Button

Press TIMER button at unit ON to set TIMER OFF; HOUR OFF blinks. Press TIMER button at unite OFF to set TIMER ON; HOUR ON blinks. In this case, pressing + or - button changes time setting. Holding down either button rapidly changes time setting (time setting range 0.5 - 24 hours). Press TIMER button again to confirm setting; HOUR ON/OFF stops blinking. If there is not any operation of button within 5 seconds during HOUR ON/OFF blinking, TIMER setting will be canceled.

### 12) Turbo Button

Boost the cooling or heating airflow, allowing the unit to reach the preset temperature in the shortest amount of time.

### 13) Sleep Button

Press this button to go into the SLEEP operation mode. Press it again to cancel this function. This function is available in COOL , HEAT (Only for models with heating function) or DRY mode to maintain the most comfortable temperature for you.

### 14) Light Button

Turns the light on the indoor display on and off.

### 15) Combination of “+” and “-” Buttons

Press “+” and “-” buttons simultaneously to lock or unlock the keypad

### 16) Combination of “Mode” and “-” Buttons

Press “Mode” and “-” buttons simultaneously will switch between Fahrenheit and Centigrade.

# Refrigerant Lines Connection, Evacuating and Charging

## Refrigerant Lines Preparation & Connection

The refrigerant lines should be kept sealed until ready to be connected. Follow the following steps to ensure a quality leak proof installation:

### Step 1. Refrigerant Line Connection

Carefully bend and cut the tubing to prepare for flaring. Use a flaring tool designed for R410a, following the recommended manufacturer's procedure. Tighten the flare nut to the indicated torque by using a spanner wrench and a torque wrench. Connect the indoor unit first, then the outdoor unit. Use the 3/8" to 1/2" flare adapter if needed.

#### Note:

Over tightening flare nuts may damage flare connections and may cause leaks.

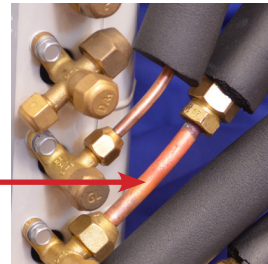

Tubing Size	Torque (foot-pounds)	Torque (inch-pounds)
1/4"	10-13	124-159
3/8"	25-31	301-372
1/2"	36-45	434-540
5/8"	50-60	602-726

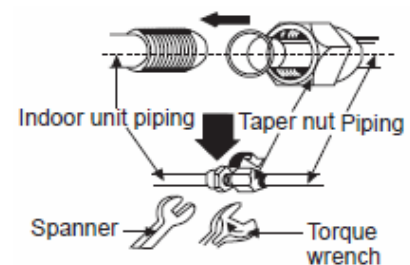

### Step 2. System Leak Check

Refrigerant lines should be pressurized prior to evacuating system to check for leaks.

Use only dry nitrogen with a pressure regulator for pressurizing unit. Pressurize with 150 psi of dry nitrogen. Apply soap and water to check whether the joints are leaky. A leak detector may also be used for a leakage test.

#### Hint:

You may want to perform leak testing and evacuation before wiring to save time, electrical connections can be completed while your vacuum pump is running.

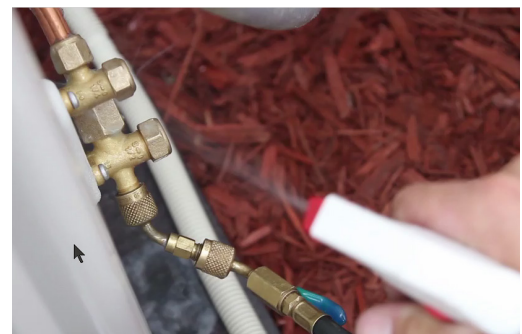

### Step 3. System Evacuation

Note: The outdoor unit contains a refrigerant charge, leave liquid and gas valves closed.

1. After no leaks have been detected, connect a vacuum pump to the outdoor unit.
2. Connect appropriate hoses to manifold gauge, vacuum pump and unit refrigeration connections.
3. Evacuate the system until the micron gauge reads no higher than 350 microns.
4. Close valve to vacuum pump; if pressure does not rise above 500 microns after one minute, the evacuation should be complete.
5. If it does rise, check for leaks and/or evacuate longer.
6. For refrigerant lines longer than 25 feet, refer to installation instructions chart included with the unit installation manual for additional charge.



## Refrigerant Charging Procedure

Please refer to your units installation manual for proper charge. If your lineset exceeds the chart below for your model, additional charge may be required. The charge must be weighed in with a refrigerant charging scale.

***You can only add additional refrigerant to a new installation. If a low or high charge is suspected, you must reclaim the refrigerant, then weigh in the correct amount per specifications including any additional for long linesets. It is important to check for leaks before adding refrigerant.***

### 1. Determine additional refrigerant charge.

The RIO single zone units contain a factory charge adequate for up to a total length of refrigerant line as indicated in the chart below. Additional refrigerant will need to be added for total lengths over the listed length. Confirm the following chart with your installation manual for additional charge amounts:

	GWH09KF-A3DNB1A	GWH12KF-A3DNB1A	GWH09KF-D3DNB1C	GWH12KF-D3DNB1C
<b>Additional Charge</b>	<b>0.2 oz./ft.</b>	<b>0.2 oz./ft.</b>	<b>0.2 oz./ft.</b>	<b>0.2 oz./ft.</b>
<b>Max Length without Additional Charge</b>	<b>25 ft.</b>	<b>25 ft.</b>	<b>25 ft.</b>	<b>25 ft.</b>
<b>Factory Charge</b>	<b>35.3 oz.</b>	<b>35.3 oz.</b>	<b>26.1 oz.</b>	<b>35.3 oz.</b>
<b>Max. Total Piping Length</b>	<b>49 ft.</b>	<b>66 ft.</b>	<b>50 ft.</b>	<b>50 ft.</b>
<b>Max. Elevation</b>	<b>33 ft.</b>	<b>33 ft.</b>	<b>33 ft.</b>	<b>33 ft.</b>
	GWH18KG-D3DNB1C	GWH24KG-D3DNB1A		
<b>Additional Charge</b>	<b>0.2 oz./ft.</b>	<b>0.22 oz./ft.</b>		
<b>Max Length without Additional Charge</b>	<b>25 ft.</b>	<b>25 ft.</b>		
<b>Factory Charge</b>	<b>45.9 oz.</b>	<b>54.7 oz.</b>		
<b>Max. Total Piping Length</b>	<b>50 ft.</b>	<b>50 ft.</b>		
<b>Max. Elevation</b>	<b>33 ft.</b>	<b>33 ft.</b>		

# Refrigerant Charging Procedure

## 2. Leak Testing

Follow the procedures for leak testing with nitrogen prior to adding charge on a new installation or existing one suspected for leaks. See preceding page.



## 3. Attach hoses to the unit and vacuum pump

5/16" x 1/4" adapter may be required to connect hose to port.

Check to insure that the liquid and gas valves are closed on the unit. Close all valves on your gauge set, then connect the vacuum pump to your gauge set. Pump down lineset and indoor unit. This step will be repeated for all zones.



## 4. Zero charging scale

Place the refrigerant tank on the charging scale. Open the tank valve, turn on the scale, then zero the scale.



## Refrigerant Charging Procedure, cont.

### 5. Begin adding additional refrigerant

Charging should be completed with the unit off (not running) and through the liquid side with liquid refrigerant. If there are no ports on the liquid side, use the gas side port connection, charging with liquid.

**Record the amount of additional charge for future reference.**



### 6. Charge to the correct weight

If the scale was zeroed with the refrigerant tank on the scale, the amount added to the system will be a negative amount since it was removed from the tank. After the proper amount of refrigerant has been weighed in, close the manifold valve.



### 7. Remove refrigerant tank

Close the tank valve, then carefully remove the hose and adapter. Replace the charging port cap back on the outdoor unit valves. On new installations, open all liquid and vapor service valves.

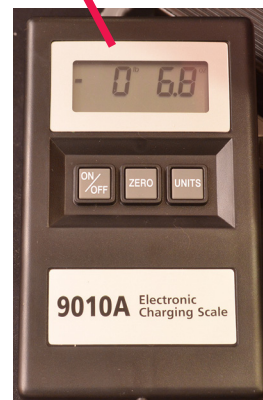

# Installation

Proper installation site is vital for correct and efficient operation of the unit. Avoid the following sites where:

- Strong heat sources, vapors, flammable gas or volatile liquids are emitted.
- High-frequency electro-magnetic waves are generated by radio equipment, welders and medical equipment.
- The air is contaminated with industrial vapors and oils.
- The air contains sulfurous gas such as in hot spring zones.
- Poor air quality exists.

## Indoor Unit



The air inlet and outlet should be away from any obstructions. Ensure the air will easily circulate through the entire room.

1. Select a site where the condensate can be easily routed or consider a condensate removal pump.
2. Select a place where it is out of reach of children.
3. Select a place that has adequate mounting structure, strong enough to withstand the full weight and vibration of the unit.
4. Be sure to leave enough space to allow access for routine maintenance. Refer to unit installation specifications for clearances. Select a place more than 3 feet away from any TV or other electrical appliances

## Outdoor Unit



1. Select a suitable site where proper drainage will occur.
2. Select a site where there is sufficient ventilation.
3. Select a site where there is no obstruction blocking the inlet and outlet.
4. The site should be able to withstand the full weight of the unit.
5. Try to limit expose to direct sunlight or strong winds.
6. Make sure that the outdoor unit is installed in accordance with the installations instructions, and is convenient for maintenance and repair.
7. Refer to your outdoor unit installation manual for maximum lineset lengths and heights. This could be a factor in determining outdoor location.
8. Select a place where it is out of reach of children.
9. Install Heat Pump legs to allow for proper drainage.
10. Install drain fitting in bottom of outdoor unit



# Installation

## Mounting Plate Installation



1. The mounting plate should be installed horizontally and level.
2. Measure the center of the indoor unit. Please note, that depending on model, the center of the bracket may not correspond with the center of the unit.
3. Attach the mounting plate on the wall with screws.
4. Be sure that the mounting plate has been attached firmly enough to withstand approximately 132 pounds.
5. Refer to specific models for dimensional data.

## Locate and Drill Hole



1. The piping can exit the indoor unit from either side, see pictured below.
2. Drill a 2-1/2" diameter hole at a slightly downward angle to the outdoor side.
3. Note: The outdoor hole should be approximately 1/4" lower than the indoor hole.
4. Insert the piping-hole sleeve into the hole to prevent the piping and wiring from being damaged when passing through the hole.

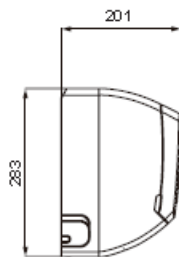
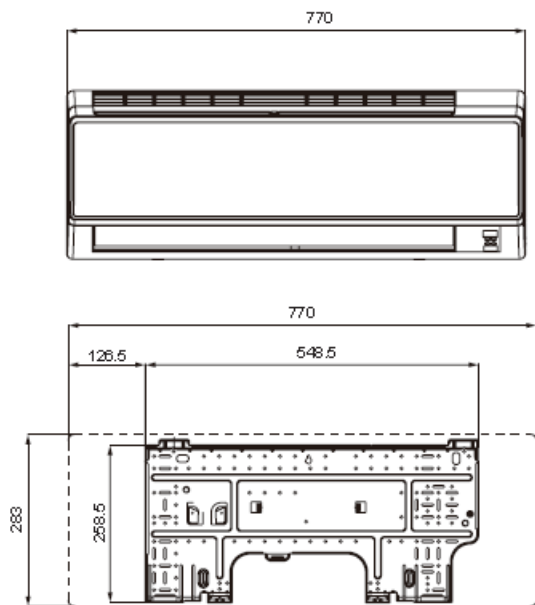

Unit: mm

# Installation

## Install Drain Hose

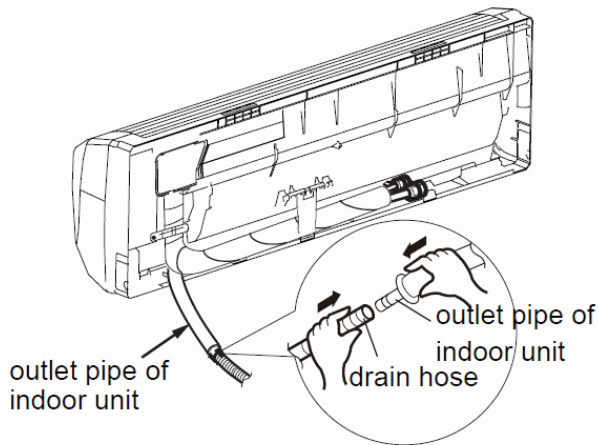

1. Connect the drain hose to the outlet pipe of the indoor unit using appropriate connections.
2. Insulate the condensate to prevent condensation.
3. Fasten the condensate, lineset and wiring together to prevent damage and movement. Slant the drain hose downward for smooth drainage.

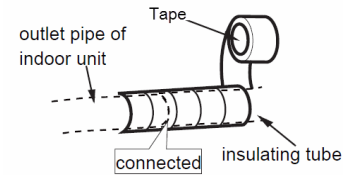
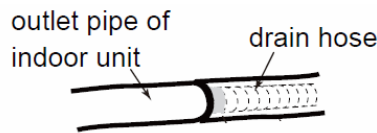

## Install Line Set



1. Install lineset and wiring from the outside through the wall sleeve.
2. Bend the indoor lineset. Note: a tube bender will speed up the process.
3. Carefully remove flare nut from indoor coil. Listen for holding charge from indoor unit. No charge may indicate a leak and should be tested.
4. Use a flaring tool if necessary to create the flare, connect tubing tightening to the torque listed below.

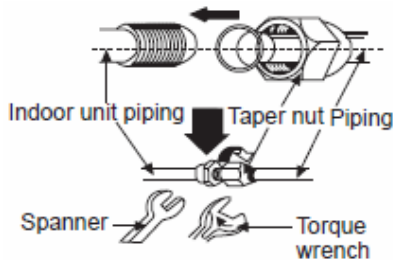

Tubing Size	Torque (foot-pounds)	Torque (inch-pounds)
1/4"	10-13	124-159
3/8"	25-31	301-372
1/2"	36-45	434-540
5/8"	50-60	602-726





# Installation

## Pressure and Leak Test

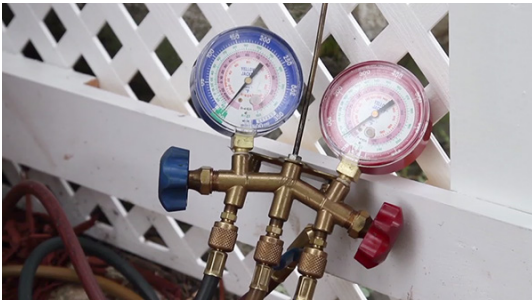

1. Use only dry nitrogen with a pressure regulator for pressurizing unit. Pressurize with 150 psi of dry nitrogen.
2. Apply soap and water to check whether the joints are leaky. A leak detector can also be applied for a leakage test.

Hint: You may want to perform leak testing and evacuation before wiring to save time, electrical connections can be completed while your vacuum pump is running.

## Evacuating the System

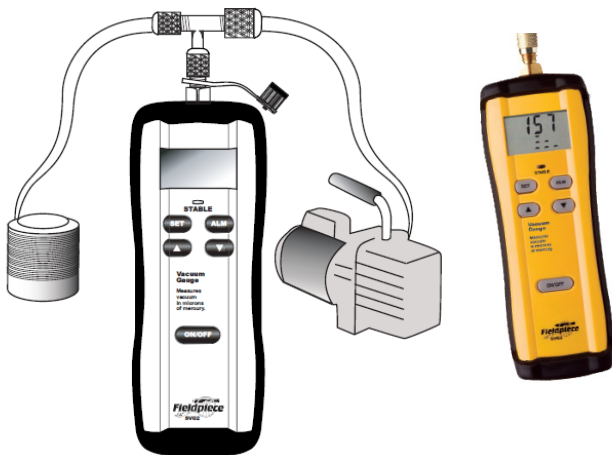

Note: The outdoor unit contains a refrigerant charge, leave liquid and gas valves closed.

1. After no leaks have been detected, connect a vacuum pump to the outdoor unit.
2. Connect appropriate hoses to manifold gauge, vacuum pump and unit refrigeration connections.
3. Evacuate the system until the micron gauge reads no higher than 350 microns.
4. Close valve to vacuum pump; if pressure does not rise above 500 microns after one minute, the evacuation should be complete.
5. If it does rise, check for leaks and/or evacuate longer.
6. For refrigerant lines longer than 25 feet, refer to installation instructions chart included with the unit installation manual for additional charge.

# Installation

## Connect the Outdoor Wiring

115 volt unit  
shown

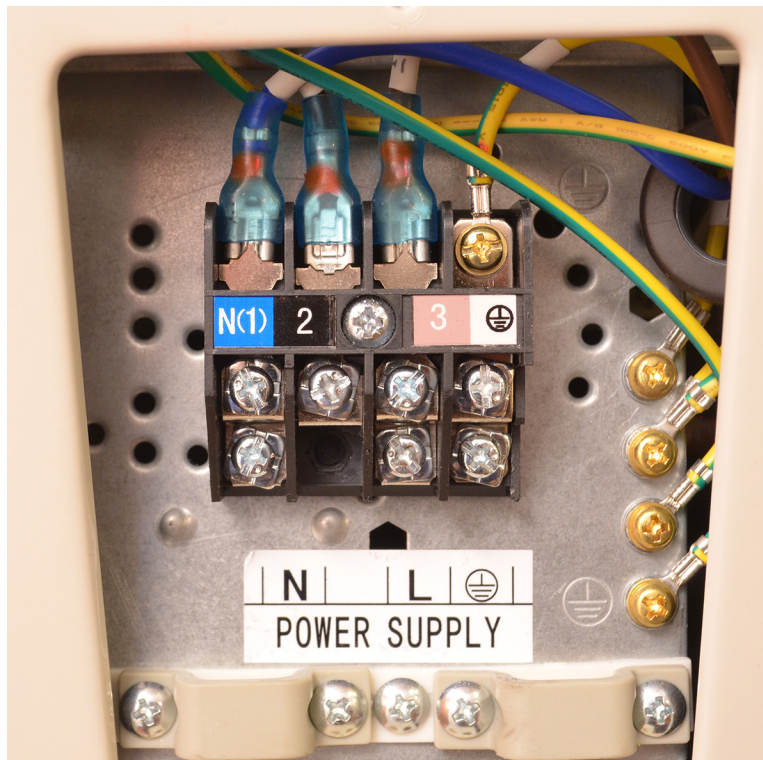

### 115 Volt unit

1. Remove the handle on the right side plate of the outdoor unit.
2. Connect wiring from indoor unit to 1,2,3 & ground, being careful to match color code of indoor connections. Repeat this for each indoor unit.
3. Connect power wiring form outdoor disconnect to N, L and ground.
4. Check all connections to tightness.
5. Reinstall the cover/handle.

Note: Follow all local electrical codes for electrical wiring.

### 240 Volt unit

1. Remove the handle on the right side plate of the outdoor unit.
2. Connect wiring from indoor unit to 1,2,3 & ground, being careful to match color code of indoor connections. Repeat this for each indoor unit.
3. Connect power wiring form outdoor disconnect to L1, L2 and ground.
4. Check all connections to tightness.
5. Reinstall the cover/handle.

Note: Follow all local electrical codes for electrical wiring.

# Filter Maintenance and Emergency Operation

## Cleaning Air Filter



1. Lift open the front panel as shown on the picture
2. The first stage filter can be cleaned with a vacuum cleaner or by washing with a mild soap and  $< 113^{\circ}$  F water.
3. The 2nd filter can be washed, use a vacuum cleaner to clean any dust, lint, etc.
4. Thoroughly dry filters before replacing in unit.

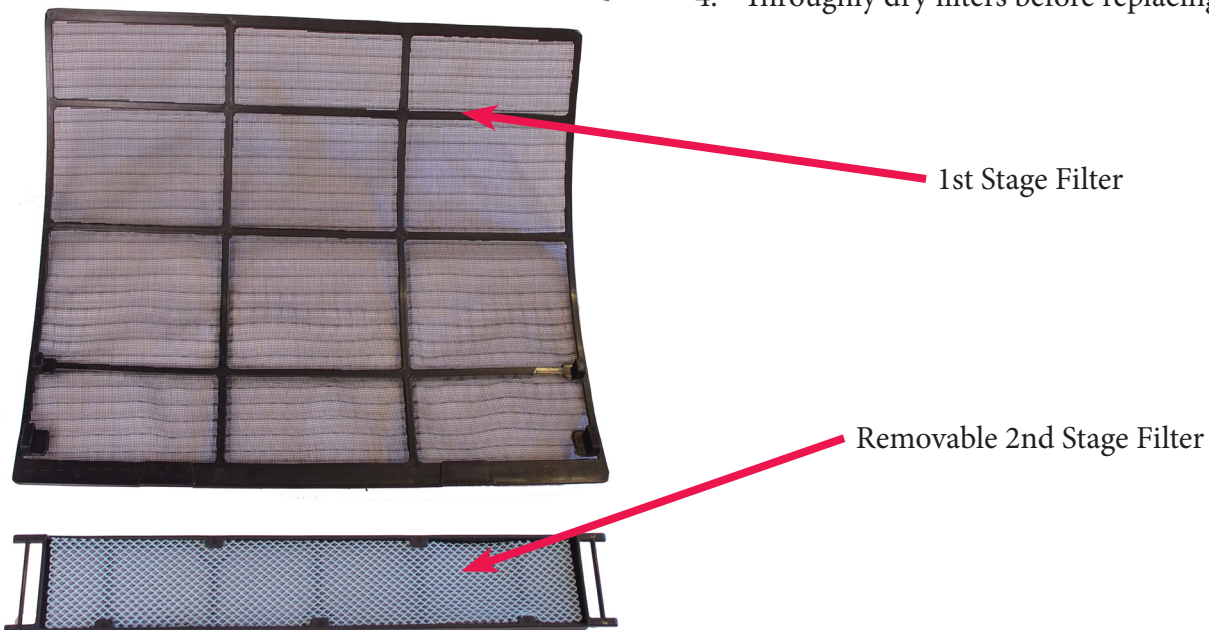

# Electrical Schematics

**GWH09KF-A3DNB1A, GWH012KF-A3DNB1A**

## Indoor Board

Symbol	Color Symbol	Symbol	Color Symbol
WH	White	BN	Brown
UE	Yellow	BU	Blue
RD	Red	BK	Black
YEGN	Yellow/Green		Protective Earth

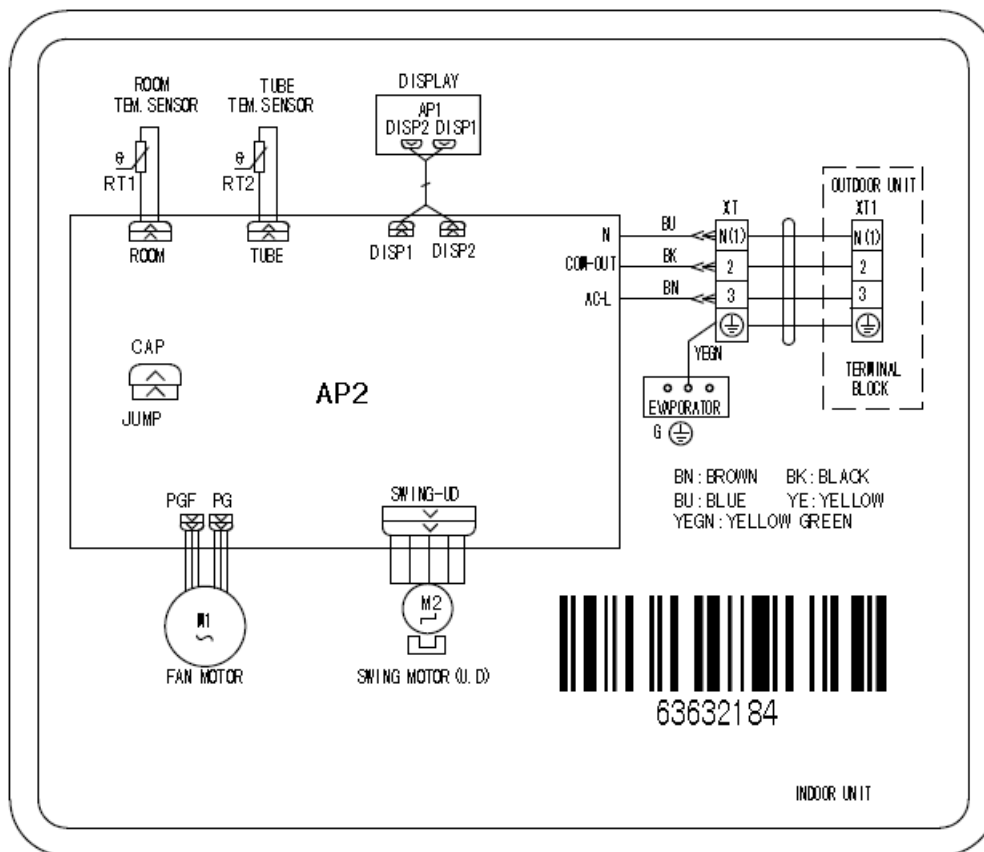

*These circuit diagrams are subject to change without notice, please refer to the one supplied with the unit.*

# Electrical Schematics

## GWH09KF-A3DNB1A, GWH012KF-A3DNB1A

### Outdoor Unit

Symbol	Parts Name	Symbol	Parts Name
N L	Neutral Wire, 110v Live Wire	WH	White
4YV	4-Way Valve	YE	Yellow
EKV	Electric Expansion Valve	RD	Red
L	Reactor	BN	Brown
COMP	Compressor	BU	Blue
	Protective Earth	BK	Black
SAT	Overload	YEGN	Yellow/Green

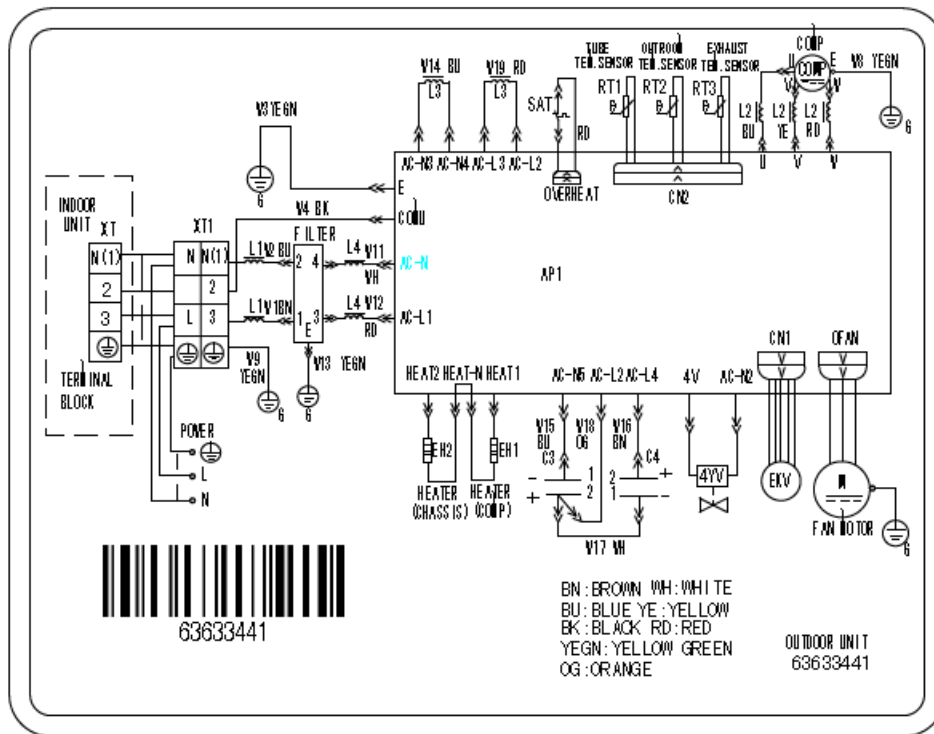

*These circuit diagrams are subject to change without notice, please refer to the one supplied with the unit.*

# Electrical Schematics

## GWH09KF-D3DNB1C, GWH012KF-D3DNB1C

### ● Indoor Unit

Symbol	Color symbol	Symbol	Color symbol
WH	WHITE	BN	BROWN
YE	YELLOW	BU	BLUE
RD	RED	BK	BLACK
YEGN	YELLOW/GREEN	⊕	PROTECTIVE EARTH

### ● Outdoor Unit

Symbol	Parts name	Symbol	Color symbol
L1 L2	NEUTRAL WIRE, LIVE WIRE	WH	WHITE
4YV	4-WAY VALVE	YE	YELLOW
EKV	ELETRIC EXPANSION VALVE	RD	RED
L	REACTOR	BN	SAT OVERLOAD BN BROWN
COMP	COMPRESSOR	BU	BLUE
⊕	PROTECTIVE EARTH	BK	BLACK
		YEGN	YELLOW GREEN

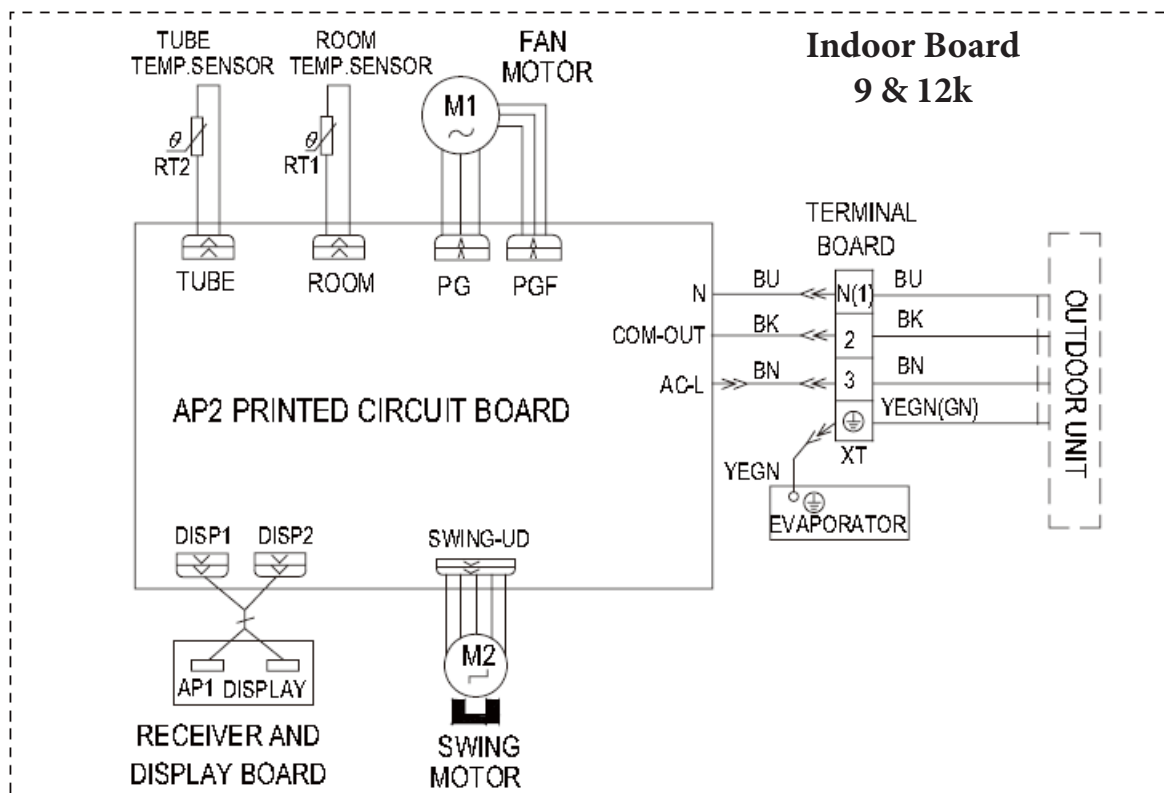

*These circuit diagrams are subject to change without notice, please refer to the one supplied with the unit.*

# Electrical Schematics

GWH09KF-D3DNB1C, GWH012KF-D3DNB1C

## Outdoor Unit

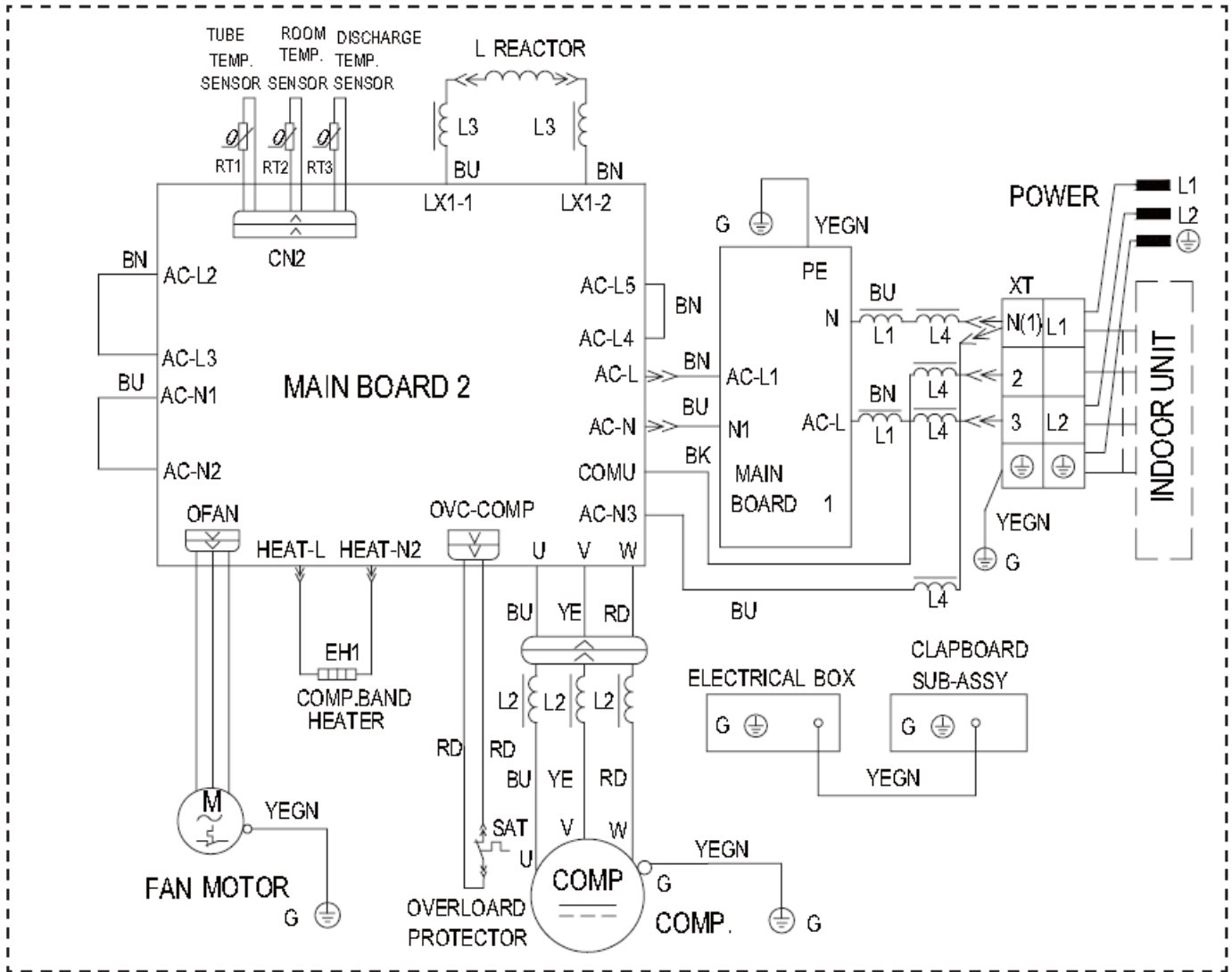

*These circuit diagrams are subject to change without notice, please refer to the one supplied with the unit.*

# Electrical Schematics

## GWH18KG-D3DNB1C Indoor Unit

Symbol	Color symbol	Symbol	Parts name
OG	ORANGE		PROTECTIVE EARTH
WH	WHITE	COMP	COMPRESSOR
YE	YELLOW	SAT	OVERLOAD
RD	RED	4YV	4-WAY VALVE
YEGN	YELLOW GREEN	XT	TERMINAL BLOCK
BN	BROWN		
BU	BLUE		
BK	BLACK		

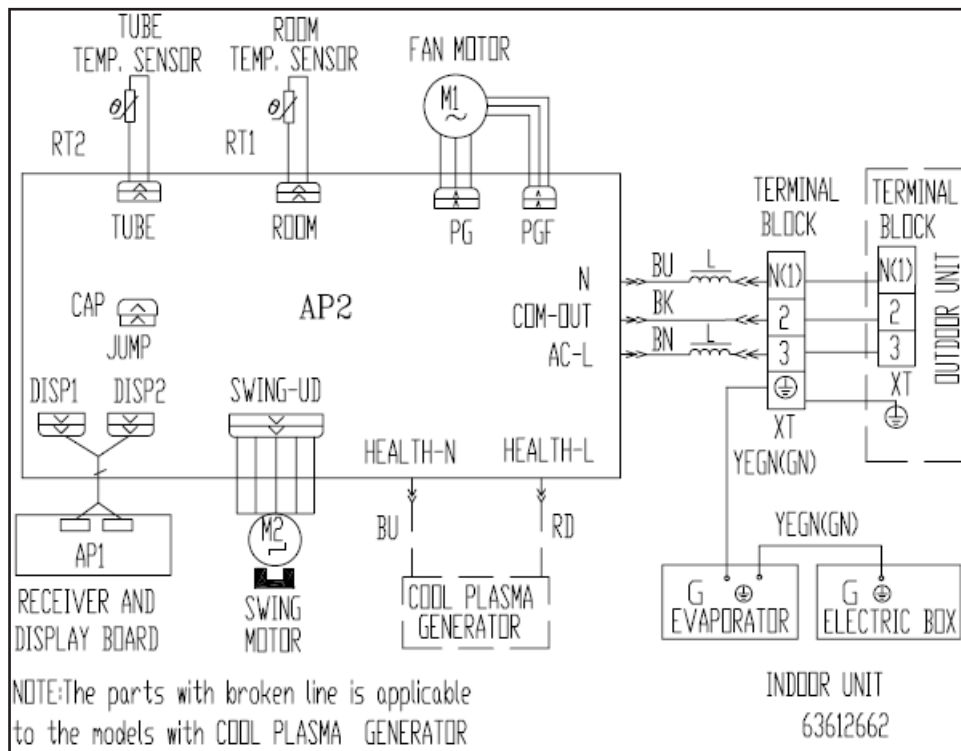

*These circuit diagrams are subject to change without notice, please refer to the one supplied with the unit.*



# Electrical Schematics

## GGWH24KG-D3DNB1A Indoor Unit

Symbol	Color symbol	Symbol	Parts name
OG	ORANGE		PROTECTIVE EARTH
WH	WHITE	COMP	COMPRESSOR
YE	YELLOW	SAT	OVERLOAD
RD	RED	4YV	4-WAY VALVE
YEGN	YELLOW GREEN	XT	TERMINAL BLOCK
BN	BROWN		
BU	BLUE		
BK	BLACK		

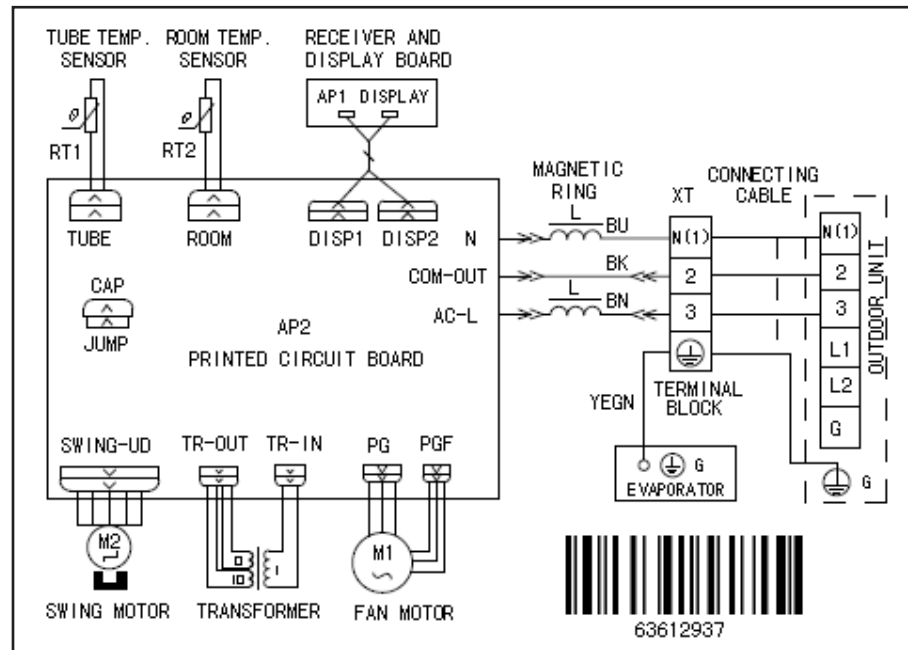

# Electrical Schematics

## GGWH24KG-D3DNB1A Indoor Unit

Symbol	Color symbol	Symbol	Parts name
OG	ORANGE		PROTECTIVE EARTH
WH	WHITE	COMP	COMPRESSOR
YE	YELLOW	SAT	OVERLOAD
RD	RED	4YV	4-WAY VALVE
YEGN	YELLOW GREEN	XT	TERMINAL BLOCK
BN	BROWN		
BU	BLUE		
BK	BLACK		

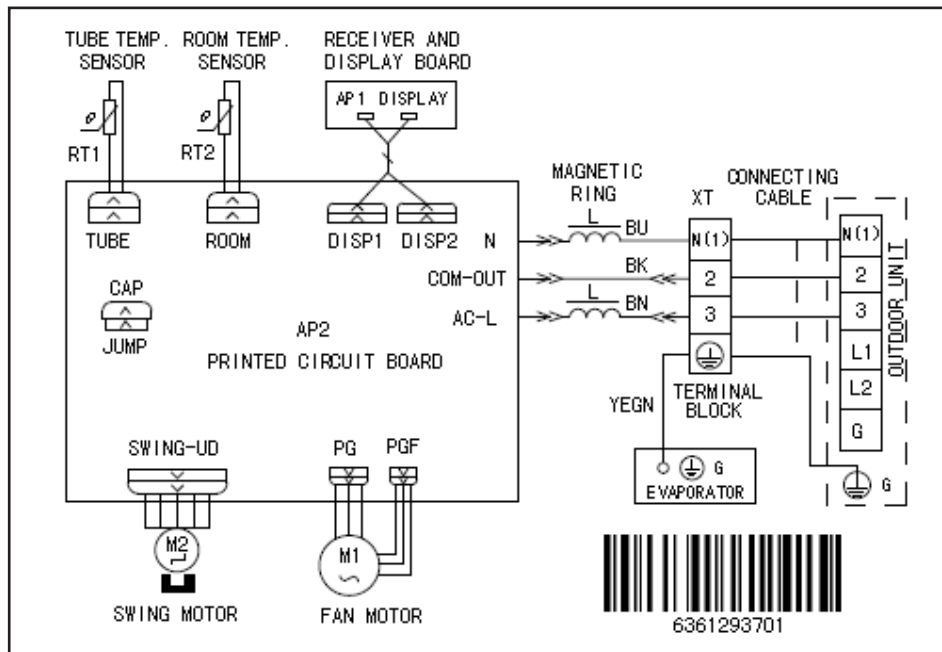

# Electrical Schematics

GWH18KG-D3DNB1C  
GWH24KG-D3DNB1A

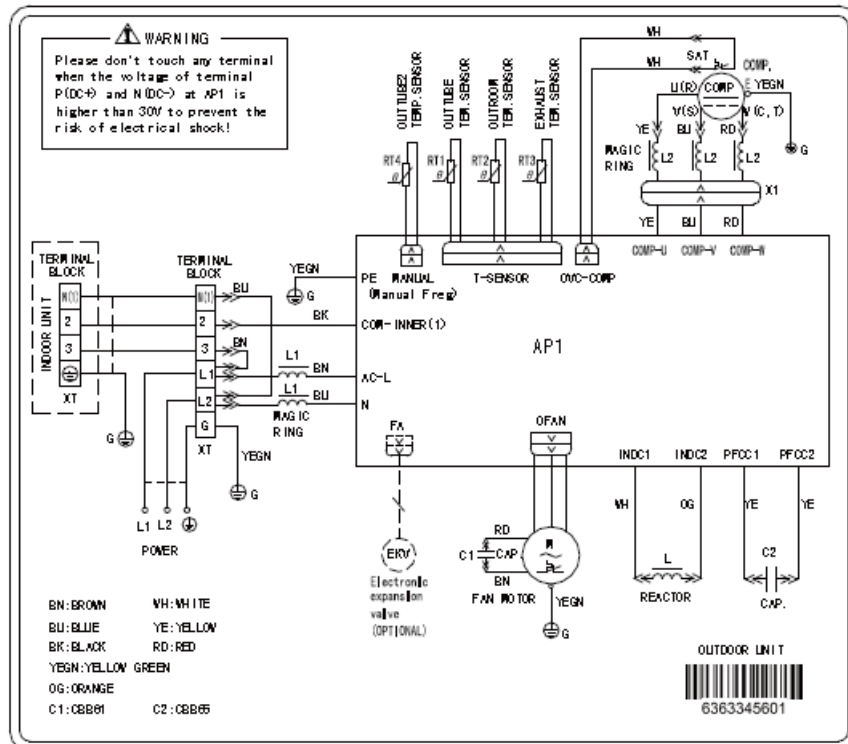
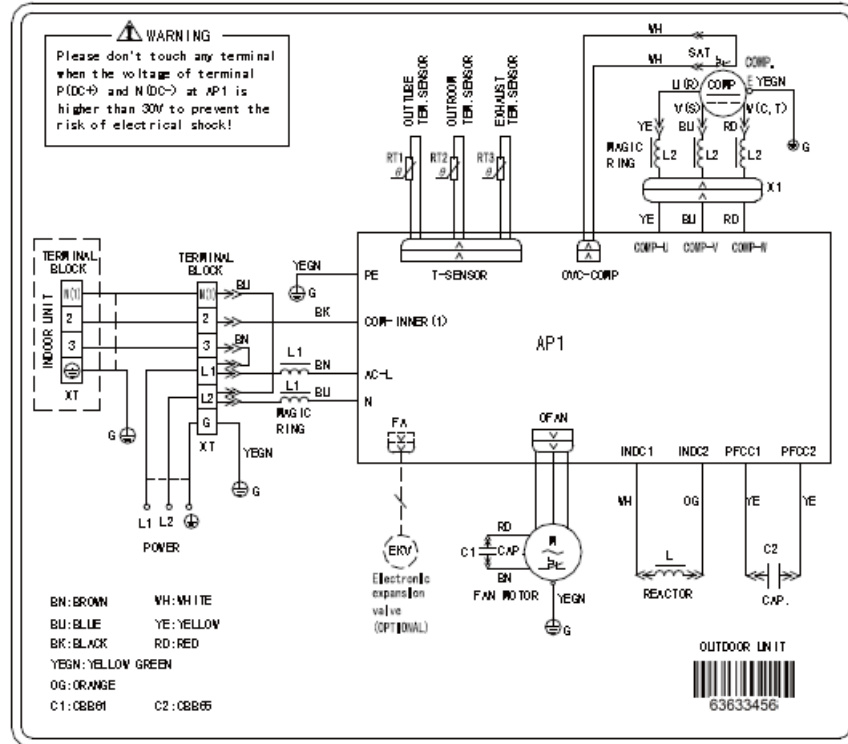

These circuit diagrams are subject to change without notice, please refer to the one supplied with the unit.

# Electrical Schematics

**GWH18KG-D3DNB1C**  
**GWH24KG-D3DNB1A**

**⚠ WARNING**

Please don't touch any terminal when the voltage of terminal P(DC+) and N(DC-) at AP1 is higher than 30V to prevent the risk of electrical shock!

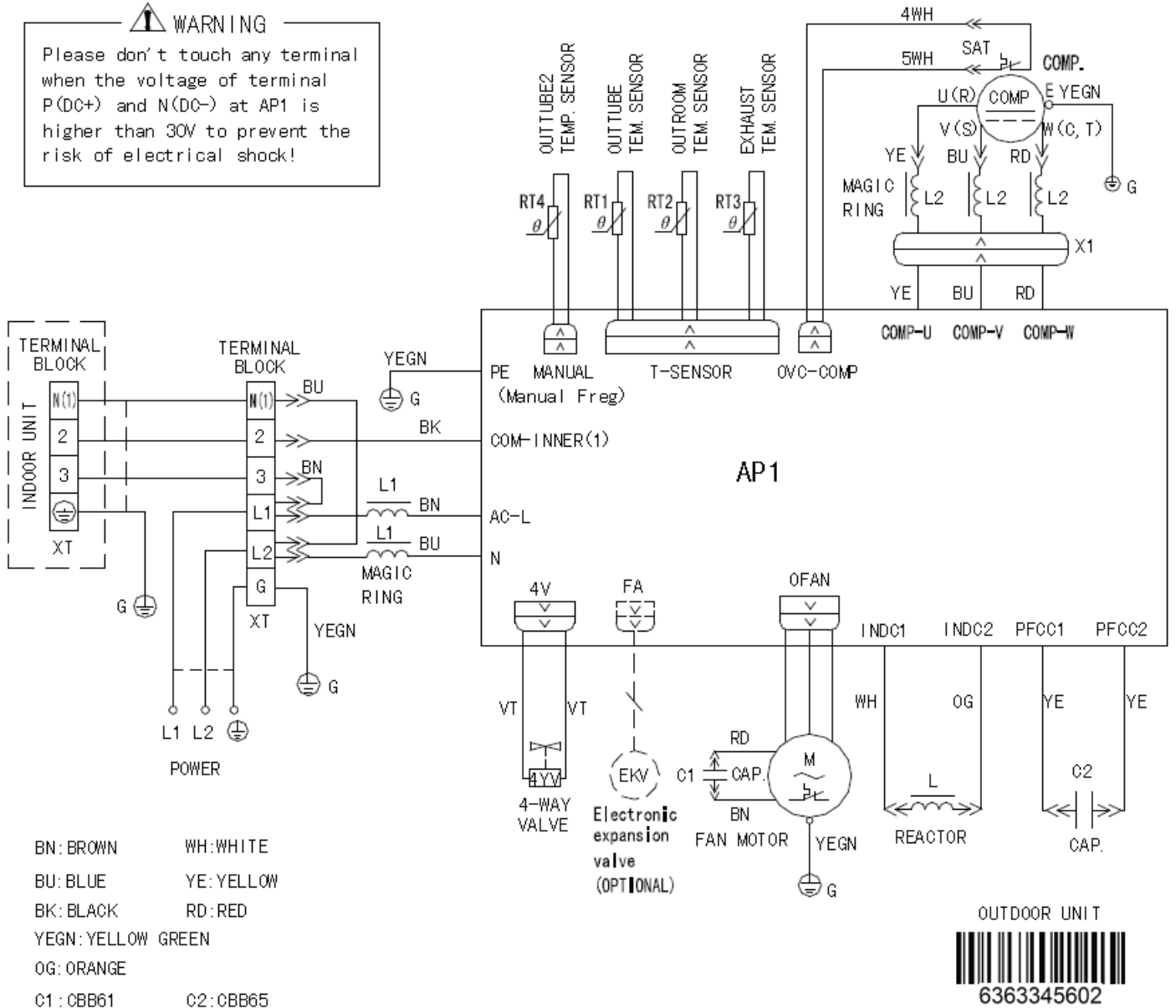

*These circuit diagrams are subject to change without notice, please refer to the one supplied with the unit.*

# Printed Circuit Boards

## AP-1 Circuit Board

Compressor  
Heater Band

N2 - Voltage  
Terminal

4-Way Valve

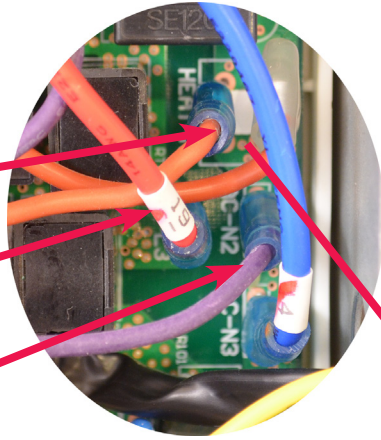

Compressor Wires

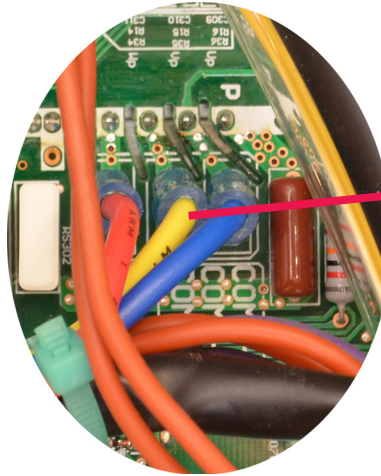

Thermistor wires

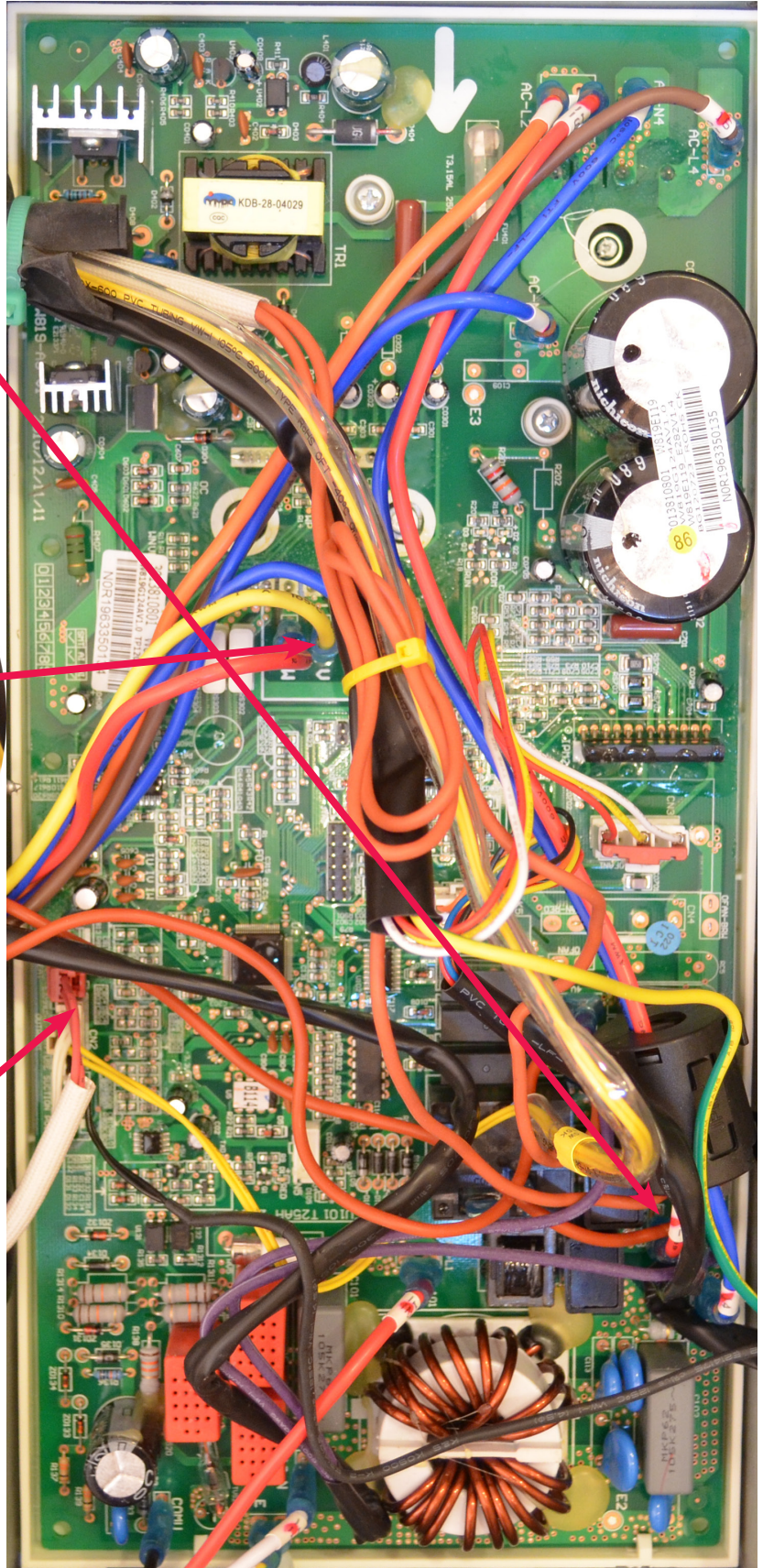
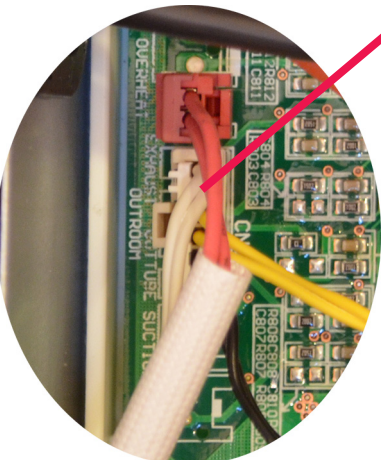

# Troubleshooting Indoor Components

## Indoor Fan Motor Troubleshooting

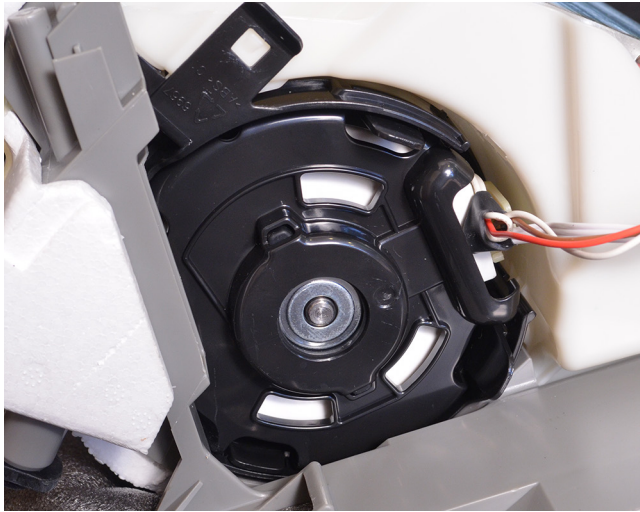

To check the condition of the indoor fan motor voltage measurements and resistance measurements can be compared to the following charts. Care must be taken when checking voltage measurements, all wires and terminals must be isolated for safety. Resistance measurements must be taken with power off and “PG” connector removed from the circuit board.

The following chart indicates approximate voltage measurements, readings may vary slightly depending on models and should be used as a reference only. Voltages should be taken with unit running.

PG Wire Connector	Low	Medium	High	Turbo
Brown - White	130 vac	147 vac	161 vac	225 vac
Brown - Red	148 vac	184 vac	210 vac	340 vac
White - Red	123 vac	150 vac	180 vac	205 vac

The following chart indicates approximate resistance measurements, readings may vary slightly depending on models and should be used as a reference only. Turn power off and remove connector from circuit board before reading measurements.

PG Wire Connector	Resistance (ohms)
Brown - White	97 $\Omega$
Brown - Red	174 $\Omega$
White - Red	78 $\Omega$

# Troubleshooting Indoor Components

## Step Motor Troubleshooting

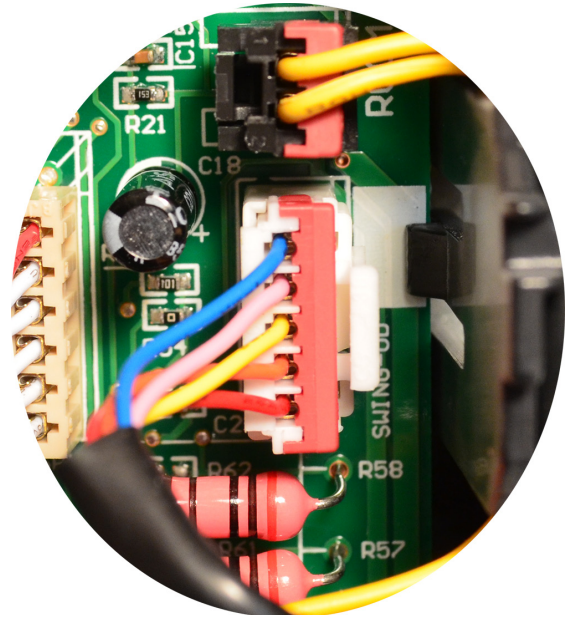
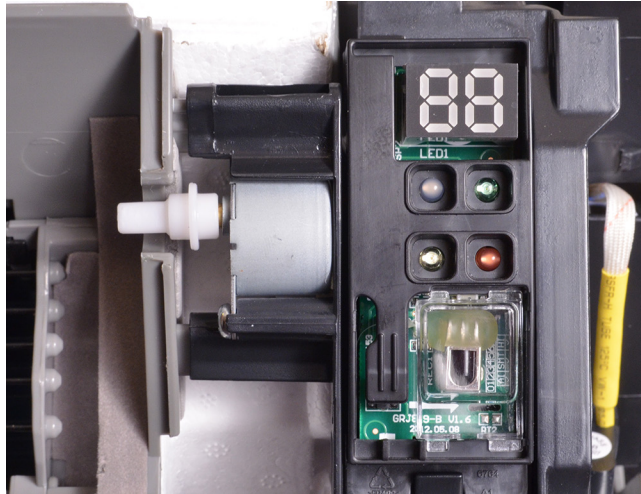

To check the condition of the indoor step (swing) motor resistance measurements may be compared to the following chart. Resistance measurements must be taken with power off and the connector removed from the board. The following charts indicate approximate readings and may vary with different models. **Turn power off and remove connector from circuit board.**

Connector	Blue	Pink	Yellow	Orange	Red
Blue		397 $\Omega$	402 $\Omega$	400 $\Omega$	198 $\Omega$
Pink			400 $\Omega$	402 $\Omega$	198 $\Omega$
Yellow				402 $\Omega$	198 $\Omega$
Orange					198 $\Omega$
Red					

# Troubleshooting Outdoor Components

## EEV Troubleshooting

### Cooling Mode

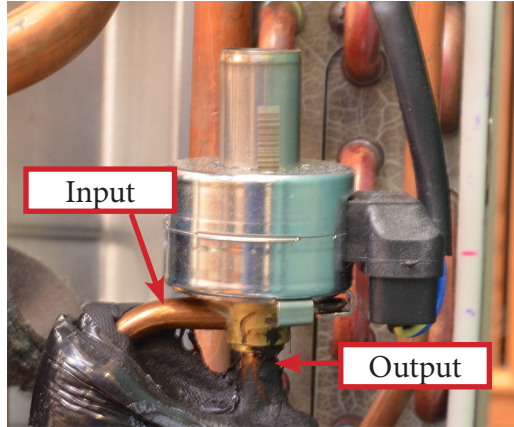

To check the operation of the EEV Valve in cooling mode, using a digital thermometer record the temperature of the input line and the output line of the valve as indicated in the picture above. With the compressor running, the input side of the valve should have a higher reading than the output side indicating that the valve is metering. If the temperature readings are the same, the valve is fully open and the valve is not metering. Since the pressures and frequency are controlled by the G10 technology of the outdoor circuit board, there are no pressure checks that can be made.

### Heating Mode

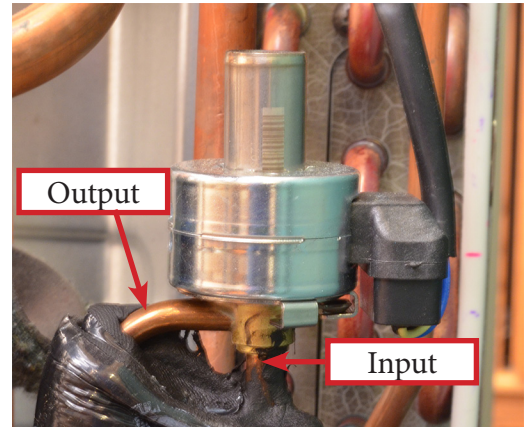

To check the operation of the EEV Valve in heating mode, using a digital thermometer record the temperature of the input line and the output line of the valve as indicated in the picture above. With the compressor running, the input side of the valve should have a higher reading than the output side indicating that the valve is metering. If the temperature readings are the same, the valve is fully open and the valve is not metering. Since the pressures and frequency are controlled by the G10 technology of the outdoor circuit board, there are no pressure checks that can be made.

Resistance readings of EEV valve with wire plug disconnected from circuit board. Power to unit should be off when making resistance readings. Readings below are approximate values and may vary slightly with different outdoor models.

EEV $\Omega$	Orange	Red	Yellow	Black	Blue
Orange		94.6 $\Omega$	94.8 $\Omega$	94.4 $\Omega$	47.0 $\Omega$
Red			94.7 $\Omega$	94.4 $\Omega$	47.5 $\Omega$
Yellow				94.6 $\Omega$	47.7 $\Omega$
Black					47.4 $\Omega$
Blue					



# Troubleshooting Outdoor Components

## 4-Way Valve Troubleshooting

### Cooling Mode

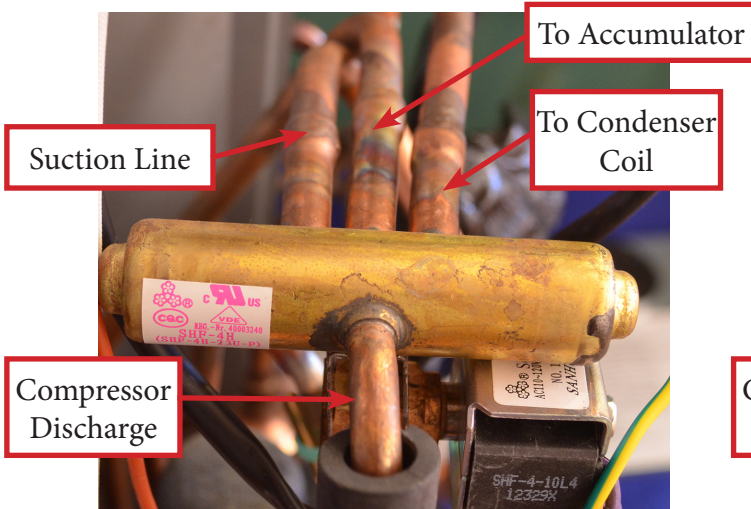

### Heating Mode

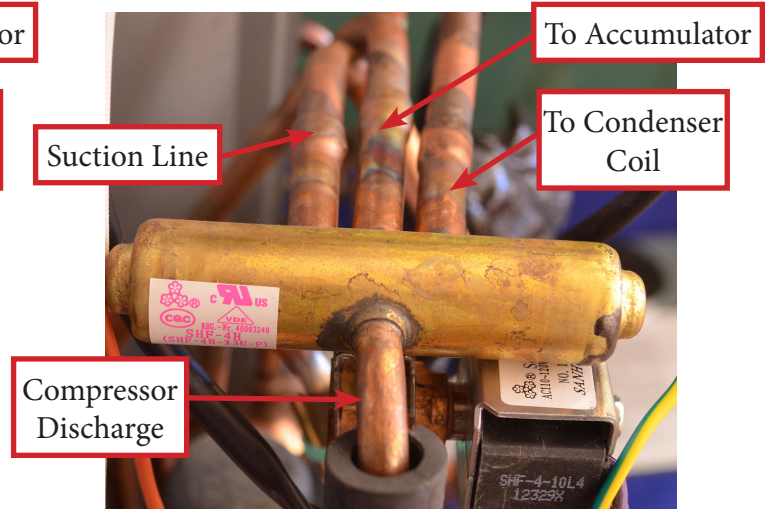

Checking the 4-way valve in cooling mode requires the measurement of 4 readings. First record the temperature of the compressor discharge tubing, secondly record the temperature of the tubing going to the condenser. There should be no more than a 10 degrees difference between the two readings.

The next set of readings will require recording the temperature of the tubing going to the suction line and the temperature of the tubing going to the accumulator. Again, if there should be less than 10 degrees difference between these readings.

A temperature reading higher than 10 degrees may indicate a leaky valve (not fully shifted) or a blockage in the valve.

### 4-Way valve solenoid resistance check:

Be sure all power is off to the unit. Remove the plug connecting the 4-way valve to the circuit board. Check the resistance with an ohmmeter. The reading should indicate 1.8k  $\Omega$ . If the reading is infinite, replace the solenoid coil.

Checking the 4-way valve in heating mode requires the measurement of 4 readings. First record the temperature of the compressor discharge tubing, secondly record the temperature of the suction line tube. There should be no more than a 10 degrees difference between the two readings.

The next set of readings will require recording the temperature of the tubing going to the condenser coil and the temperature of the tubing going to the accumulator. Again, if there should be less than 10 degrees difference between these readings.

A temperature reading higher than 10 degrees may indicate a leaky valve (not fully shifted) or a blockage in the valve.

# Troubleshooting Outdoor Components

## Temperature Sensor Check

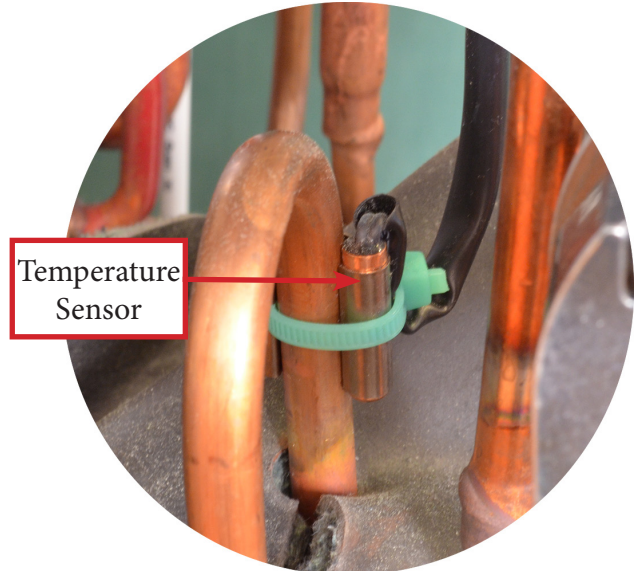

Using a glass of ice water, place the sensor into the glass with a digital thermometer. Wait a few minutes for the reading to stabilize. Compare the readings to the sensor tables in Appendix "A", if the reading are not comparable, replace the sensor. When replacing the sensor, be sure to fasten the sensor securely if it is attached to a tube.

Temp (°C)	Temp (°F)	Resistance (kΩ)		Temp (°C)	Temp (°F)	Resistance (kΩ)		Temp (°C)	Temp (°F)	Resistance (kΩ)
0	32.0	49.02		52	125.6	4.986		104	219.2	0.898
1	33.8	46.6		53	127.4	4.802		105	221.0	0.873
2	35.6	44.31		54	129.2	4.625		106	222.8	0.848
3	37.4	42.14		55	131.0	4.456		107	224.6	0.825
4	39.2	40.09		56	132.8	4.294		108	226.4	0.802
5	41.0	38.15		57	134.6	4.139		109	228.2	0.779
6	42.8	36.32		58	136.4	3.99		110	230.0	0.758
7	44.6	34.58		59	138.2	3.848		111	231.8	0.737
8	46.4	32.94		60	140.0	3.711		112	233.6	0.717
9	48.2	31.38		61	141.8	3.579		113	235.4	0.697

# Troubleshooting Outdoor Components

## Compressor Windings

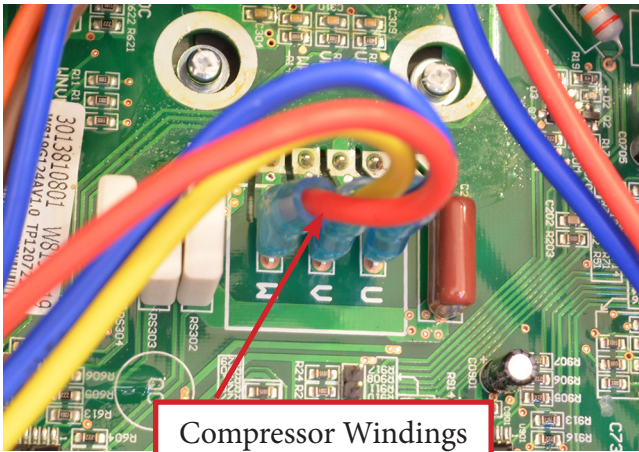

Compressor Windings  
Red, Yellow & Blue Wires

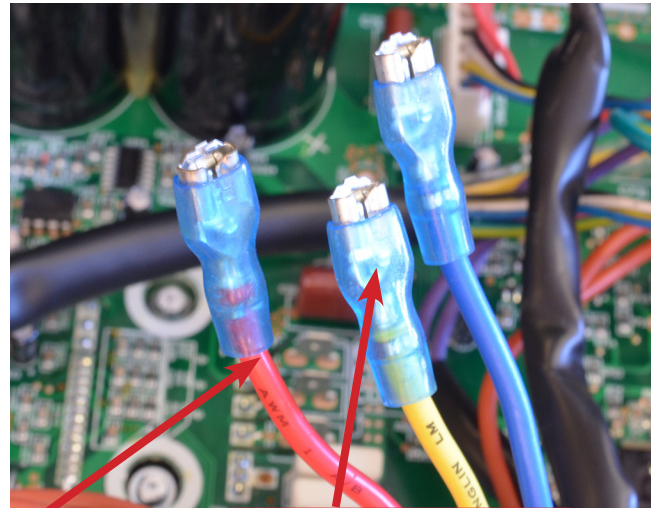

Slightly depress tab for  
easy removal

### *Compressor Winding Resistance Check:*

Remove the compressor wires from the AP1 circuit board. The wires red to yellow, yellow to blue & red to blue should have readings from 2 - 4 ohms. There should be no reading from any wire to chassis ground. If the readings between the windings differ greatly, the windings are bad. If there is a reading from any wire to the chassis, there is leakage in the windings.

## Reactor

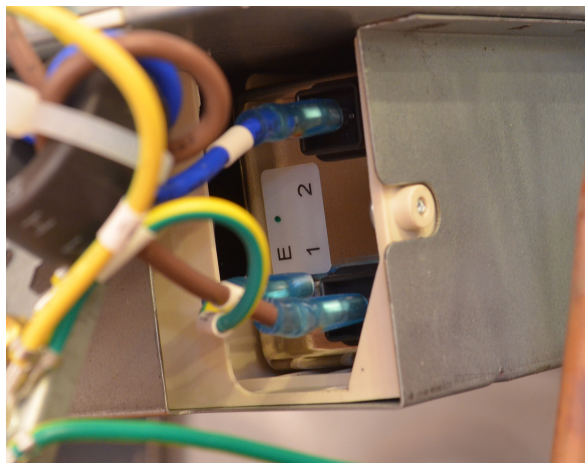

The reactor filters out electrical noise and transient voltage spikes to the control board. There will be a reading of less than 1  $\Omega$  after the wires are removed. There should be no reading from either reactor terminal to ground.

# Troubleshooting Outdoor Components

## Outdoor Fan Motor

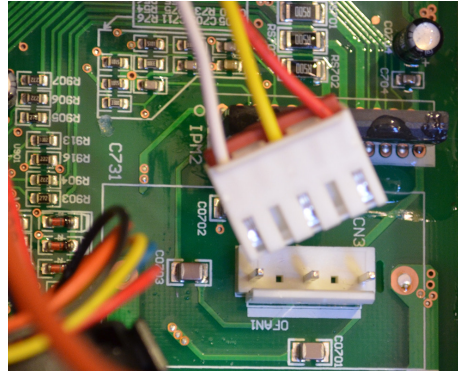
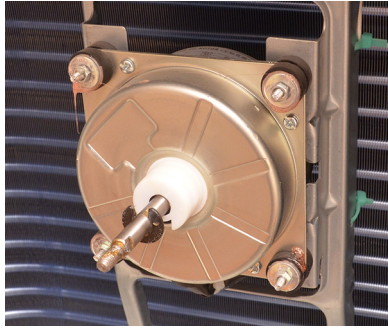

### *Outdoor Motor Winding Resistance Check:*

Disconnect power to the unit, all readings are made with no power and fan motor wires disconnected from circuit board.

The chart below will indicate the approximate resistance values in ohms. This motor is a brush-less DC motor, readings may vary slightly for different models. Plugging a known good motor in the board would provide a quick troubleshooting technique.

Motor Leads	Red	Yellow	White
Red		75 $\Omega$	74 $\Omega$
Yellow	75 $\Omega$		74 $\Omega$
White	74 $\Omega$	74 $\Omega$	

# Troubleshooting Outdoor Components

## Compressor Crankcase Heater Check

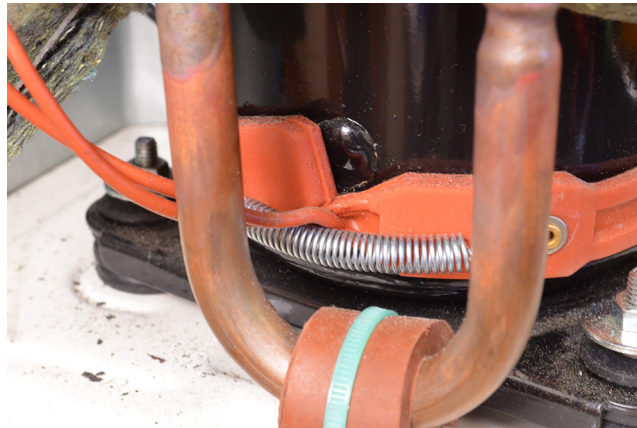

### *Compressor Crankcase Heater Resistance Check:*

Unplug the wire connector from the circuit board. The resistance should read approximately 2.15K ohms. There should be no reading from either wire to ground. If readings vary from these measurements, replace the heater.

## Refrigerant Temperature Sensors

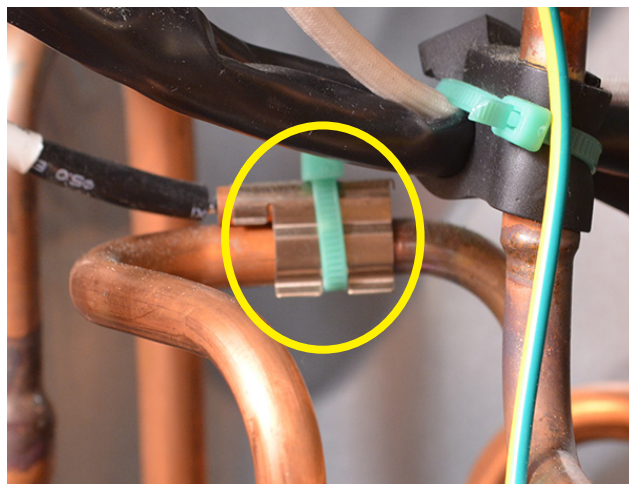

These sensors are a negative coefficient thermistor that decrease in resistance as the temperature increases. The sensors are used to monitor the temperature of the refrigerant. Please refer to the troubleshooting section for error codes generated by a sensor fault. Temperature sensors and locations will vary depending on models.

# Troubleshooting Outdoor Components

## Liquid Line Temperature Sensors



These sensors are a negative coefficient thermistor that decrease in resistance as the temperature increases. The sensors are used to monitor the temperature of the refrigerant leaving the EEV to maintain a correct superheat operation. Please refer to the troubleshooting section for error codes generated by a sensor fault. Temperature sensors and locations will vary depending on models.

# Troubleshooting Outdoor Components

## Exhaust Temperature Sensor

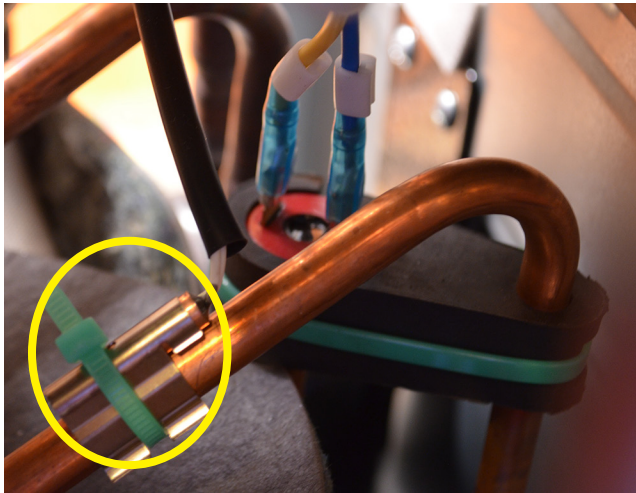

The exhaust temperature sensor monitors the refrigerant discharge temperature and will send information to the inverter control board for system operation.

The following actions can occur:

Exhaust Temperature > 208 F - Compressor will not rise above present level

Exhaust Temperature > 217 F - Compressor will run at reduced frequency

Exhaust Temperature < 194 F - Compressor off for 3 minutes minimum, the compressor will restart

Error Code F5 will be generated if the sensor is open or shorted. Please refer to the troubleshooting section for more detailed information.

# Troubleshooting Outdoor Components

## Outdoor Temperature Sensor



This sensor is a negative coefficient thermistor that will decrease in resistance as the temperature increases. This sensor will monitor the temperature of the outdoor air. The reading will be used by the inverter board to adjust frequency calculations.

Error Code F3 will be generated if the sensor is open or shorted. Please refer to the troubleshooting section for more detailed information.



# Fault Displays

## Troubleshooting Faults

Observe all electrical precautions during service of indoor and outdoor units. During Static service (servicing unit without power applied), wait 10 minutes before servicing units.

During dynamic service (servicing while unit is energized), be sure unit is properly grounded.

Troubleshooting procedure:

1. Confirmation
2. Judgment of flashing LED of Indoor/Outdoor unit
3. Check the part associated with the fault code.

### **Precautions:**

A large capacity electrolytic capacitor is used in the outdoor unit controller (inverter). Capacitor should be discharged before attempting to work on board. Electrical shock hazard will be present even after unit is disconnected from power source.

### **Confirmation:**

Confirm that the unit has proper voltage within 10% of rated value.

Observe flashing LED of indoor/outdoor unit for diagnostic information.

4 Minutes after protection stop of motor, the malfunction error code is shown. In other situations, the malfunction will be displayed by pressing the light button for 6 times within 4 seconds.

# Fault Displays

## 9,000 and 12,000 btuh units

No.	Malfuntiuon Name	Display Method of Indoor Unit			Display Method of Outdoor Unit			A/C Status	Possible Causes	
		Dual-8 Code Display	Indicator Display (during blinking, ON 0.5s and OFF 0.5s)			Indicator has 3 kinds of display status and during blinking, ON 0.5ws and OFF 0.5s				
			Operation Indicator	Cool Indicator	Heating Indicator	Yellow Indicator	Red Indicator			Green Indicator
1	High pressure protection of system	E1	OFF 3s and blink once						During cooling and drying operation, except indoor fan operates, all loads stop operation. During heating operation, the complete unit stops.	Possible reasons: 1. Refrigerant was superabundant; 2. Poor heat exchange (including filth blockage of heat exchanger and bad radiating environment); Ambient temperature is too high.
2	Antifreezing protection	E2	OFF 3S and blink twice			OFF 3S and blink 3 times			During cooling and drying operation, comporessor and outdoor fan stop while indoor fan operates.	1. Poor air-return in indoor unit; 2. Fan speed is abnormal; 3. Evaporator is dirty
3	System block or refrigerant leakage	E3	OFF 3S and blink 3 times				OFF 3S and blink 9 times		The Dual-8 Code Display will show E3 until the low pressure switch stop operation.	1. Low-pressure protection; 2. Low pressure protection of system; 3. Low pressure protection of compressor
4	High discharge temperature protection of compressor	E4	OFF 3S and blink 4 times			OFF 3S and blink 7 times			During cooling and drying operation, compressor and outdoor fan stop while indoor fan operates. During heatin operation, all loads stop	Please refer to the malfunction analysis (discharge protection, overload).
5	Overcurrent protection	E5	OFF 3S and blink 5 times			OFF 3S and blink 5 times			During cooling and drying operation, compressor and outdoor fan stop while indoor fan operates. During heatin operation, all loads stop	1. Supply voltage is unstable; 2. Supply voltage is too low and load is too high; 3. Evaporator is dirty.

# Fault Displays

## 9,000 and 12,000 btuh units

No.	Malfunction Name	Display Method of Indoor Unit				Display Method of Outdoor Unit			A/C Status	Possible Causes
		Dual-8 Code Display	Indicator Display (during blinking, ON 0.5s and OFF 0.5s)			Indicator has 3 kinds of display status and during blinking, ON 0.5s and OFF 0.5s				
			Operation Indicator	Cool Indicator	Heating Indicator	Yellow Indicator	Red Indicator	Green Indicator		
7	High temperature resistant protection	E8	OFF 3S and blink 8 times			OFF 3S and blink 6 times			During cooling and drying operation, compressor and outdoor fan stop while indoor fan operates. During heating operation, all loads stop	Refer to the malfunction analysis (overload, high temperature resistant).
8	EEPROM malfunction	EE			OFF 3S and blink 15 times	OFF 3S and blink 11 times			During cooling and drying operation, compressor and outdoor fan stop while indoor fan operates. During heating operation, all loads stop	Replace outdoor control panel AP1
9	Limit/decrease frequency due to high temperature of module	EU		OFF 3S and blink 6 times	OFF 3S and blink 6 times				All loads operate normally, while operation frequency for compressor is decreased	Discharging after the complete unit is de-energized for 20 mins, check whether the thermal grease on IPM module of outdoor control panel AP1 is sufficient and whether the radiator is inserted tightly. If its no use, please replace control panel AP1.
10	Malfunction protection of jumper cap	C5	OFF 3S and blink 15 times						Wireless remote receiver and button are effective, but can not dispose the related command	1. No jumper cap insert on mainboard; 2. Incorrect insert of jumper cap; 3. Jumper cap damaged; 4. Abnormal detecting circuit of mainboard.
11	Gathering refrigerant	F0	OFF 3S and blink 1 time	OFF 3S and blink 1 time					When the outdoor unit receive signal of Gathering refrigerant, the system will be forced to run under cooling mode for gathering refrigerant	Nominal cooling mode

# Fault Displays

## 9,000 and 12,000 btuh units

No.	Malfunction Name	Display Method of Indoor Unit			Display Method of Outdoor Unit			A/C Status	Possible Causes	
		Dual-8 Code Display	Indicator Display (during blinking, ON 0.5s and OFF 0.5s)			Indicator has 3 kinds of display status and during blinking, ON 0.5s and OFF 0.5s				
			Operation Indicator	Cool Indicator	Heating Indicator	Yellow Indicator	Red Indicator			Green Indicator
12	Indoor ambient temperature sensor is open/short circuited	F1		OFF 3S and blink 1 time					During cooling and drying operation, indoor unit operates while other loads will stop; during heating operation, the complete unit will stop operation	1. Loosening or bad contact of indoor ambient temp sensor and mainboard terminal; 2. Components in mainboard fell down leads short circuit; 3. Indoor ambient temp sensor damaged (check with sensor resistance value chart); 4. Mainboard damaged.
13	Indoor evaporator temperature sensor is open/short circuited	F2		OFF 3S and blink twice					AC stops operation once reaches the setting temperature. Cooling, drying: internal fan motor stops operation while other loads stop operation; heating: AC stop operation	1. Loosening or bad contact of indoor evaporator temp sensor and mainboard terminal; 2. Components on the mainboard fall down leads short circuit; 3. Indoor evaporator temp sensor damaged (check temp sensor value chart for testing) 4. Mainboard damaged
14	Outdoor ambient temperature sensor is open/short circuited	F3		OFF 3S and blink 3 times			OFF 3S and blink 6 times		During cooling and drying operating, compressor stops while indoor fan operates; During heating operation, the complete unit will stop operation	Outdoor temperature sensor hasn't been connected well is damaged. Please check it by referring to the resistance table for temperature sensor
15	Outdoor condenser temperature sensor is open/short circuited	F4		OFF 3S and blink 4 times			OFF 3S and blink 5 times		During cooling and drying operating, compressor stops while indoor fan operates; During heating operation, the complete unit will stop operation	Outdoor temperature sensor hasn't been connected well or is damaged. Please check it by referring to the resistance table for temperature sensor

# Fault Displays

## 9,000 and 12,000 btuh units

No.	Malfunction Name	Display Method of Indoor Unit			Display Method of Outdoor Unit			A/C Status	Possible Causes	
		Dual-8 Code Display	Indicator Display (during blinking, ON 0.5s and OFF 0.5s)			Indicator has 3 kinds of display status and during blinking, ON 0.5s and OFF 0.5s				
			Operation Indicator	Cool Indicator	Heating Indicator	Yellow Indicator	Red Indicator			Green Indicator
16	Outdoor discharge temperature sensor is open/short circuited	F5		OFF 3S and blink 5 times		OFF 3S and blink 7 times			During cooling and drying operation, compressor will stop after operating for about 3 mins, while indoor fan will operate; During heating operation, the complete unit will stop after operating for about 3 mins	1. Outdoor temperature sensor hasn't been connected well or is damaged. Please check it by referring to the resistance table for temperature sensor; 2. The head head of temperature sensor hasn't been inserted into the copper tube
17	Limit/decrease frequency due to overload	F6		OFF 3S and blink 6times		OFF 3S and blink 3 times			All loads operate normally, while operation frequency for compressor is decreased	Refer to the malfunction analysis (overload, high temperature resistant)
18	Decrease frequency due to overcurrent	F8		OFF 3S and blink 8times		OFF 3S and blink 1 time			All loads operate normally, while operation frequency for compressor is decreased	The input supply voltage is too low; System pressure is too high and overload
19	Decrease frequency due to high air discharge	F9		OFF 3S and blink 9 times			OFF 3S and blink twice		All loads operate normally, while operation frequency for compressor is decreased	Overload or temperature is too high; Refrigerant is insufficient; Malfunction of electric expansion valve (EKV)
20	Limit/decrease frequency due to antifreezing	FH		OFF 3S and blink 2 times	OFF 3S and blink 2 times		OFF 3S and blink 4 times		All loads operate normally, while operation frequency for compressor is decreased	Poor air-return in indoor unit or fan speed is too low
21	Voltage for DC bus-bar is too high	PH		OFF 3S and blink 11 times		OFF 3S and blink 13 times			During cooling and drying operation, compressor will stop while indoor fan will operate; During heating operation, the complete unit will stop operation.	1. Measure the voltage of position L and N on wiring board (XT), if the voltage is higher than 265VAC, turn on the unit after the supply voltage is increased to the normal range; 2. If the AC input is normal, measure the voltage of electrolytic capacitor C on control panel (AP1), if its normal, theres malfunction for the circuit, please replace the control panel (AP1)

# Fault Displays

## 9,000 and 12,000 btuh units

No.	Malfunction Name	Display Method of Indoor Unit			Display Method of Outdoor Unit			A/C Status	Possible Causes	
		Dual-8 Code Display	Indicator Display (during blinking, ON 0.5s and OFF 0.5s)			Indicator has 3 kinds of display status and during blinking, ON 0.5s and OFF 0.5s				
			Operation Indicator	Cool Indicator	Heating Indicator	Yellow Indicator	Red Indicator			Green Indicator
22	Voltage of DC bus-bar is too low	PL			OFF 3S and blink 21 times	OFF 3S and blink 12 times			During cooling and drying operation, compressor will stop while indoor fan operate; During heating operation, the complete unit will stop	1. Measure the voltage of position L and N on wiring board (XT), if the voltage is higher than 265VAC, turn on the unit after the supply voltage is increased to the normal range; 2. If the AC input is normal, measure the voltage of electrolytic capacitor C on control panel (AP1), if its normal, there's malfunction for the circuit, please replace the control panel (AP1)
23	Compressor Min frequency in test state	P0		(during	(during					Showing during min cooling or min heating test
24	Compressor rated frequency in test state	P1		(during	(during					Showing during nominal cooling or nominal heating test
25	Compressor maximum frequency in test state	P2		(during	(during					Showing during max cooling or max heating test
26	Compressor intermediate frequency in test state	P3		(during	(during					Showing during middle cooling or middle heating test
27	Overcurrent protection of phase current for compressor	P5		OFF 3S and blink 15 times					During cooling and drying operation, compressor will stop while indoor fan will operate; During heating operation, the complete unit will stop operation.	Refer to the malfunction analysis (IPM protection, loss of synchronism protection and overcurrent protection of phase current for compressor)
28	Charging malfunction of capacitor	PU			OFF 3S and blink 17 times				During cooling and drying operation, compressor will stop while indoor fan will operate; During heating operation the complete unit will stop	Refer to the part three - charging malfunction analysis of capacitor

# Fault Displays

## 9,000 and 12,000 btuh units

No.	Malfunction Name	Display Method of Indoor Unit				Display Method of Outdoor Unit			A/C Status	Possible Causes
		Dual-8 Code Display	Indicator Display (during blinking, ON 0.5s and OFF 0.5s)			Indicator has 3 kinds of display status and during blinking, ON 0.5s and OFF 0.5s				
			Operation Indicator	Cool Indicator	Heating Indicator	Yellow Indicator	Red Indicator	Green Indicator		
29	Malfunction of module temperature sensor circuit	P7			OFF 3S and blink 18 times				During cooling and drying operation, compressor will stop while indoor fan will operate; During heating operation the complete unit will stop	Replace outdoor control panel AP1
30	Module high temperature protection	P8			OFF 3S and blink 19 times				During cooling and drying operation, compressor will stop while indoor fan will operate; During heating operation the complete unit will stop	After the complete unit is de-energized for 20 mins, check whether the thermal grease on IPM Module of outdoor control panel AP1 is sufficient and whether the radiator is inserted tightly. If its no use, please replace control panel AP1.
31	Decrease frequency due to high temperature resistant during heating operation	H0			OFF 3S and blink 10 times				All loads operate normally, while operation frequency for compressor is decreased	Refer to the malfunction analysis (overload, high temperature resistant)
32	Static dedusting protection	H2			OFF 3S and blink twice					
33	Overload protection for compressor	H3			OFF 3S and blink 3 times	OFF 3S and blink 8 times			During cooling and drying operation, compressor will stop while indoor fan will operate; During heating operation the complete unit will stop	1. Wiring terminal OVC-COMP is loosened. In normal state, the resistance for this terminal should be less than 1ohm; 2. Refer to the malfunction analysis (discharge protection, overload)
34	System is abnormal	H4			OFF 3S and blink 4 times	OFF 3S and blink 6 times			During cooling and drying operation, compressor will stop while indoor fan will operate; During heating operation, the complete unit will stop operation.	Refer to the malfunction analysis (overload, high temperature resistant)

# Fault Displays

## 9,000 and 12,000 btuh units

No.	Malfunction Name	Display Method of Indoor Unit			Display Method of Outdoor Unit			A/C Status	Possible Causes	
		Dual-8 Code Display	Indicator Display (during blinking, ON 0.5s and OFF 0.5s)			Indicator has 3 kinds of display status and during blinking, ON 0.5s and OFF 0.5s				
			Operation Indicator	Cool Indicator	Heating Indicator	Yellow Indicator	Red Indicator			Green Indicator
35	IPM protection	H5			OFF 3S and blink 5 times	OFF 3S and blink 4 times			During cooling and drying operation, compressor will stop while indoor fan will operate; During heating operation, the complete unit will stop operation.	Refer to the malfunction analysis (IPM protection, loss of synchronism protection and overcurrent protection of phase current for compressor.
36	Module temperature is too high	H5			OFF 3S and blink 5 times	OFF 3S and blink 10 times				
37	Internal motor (fan motor) do not operate	H6	OFF 3S and blink 11 times						Internal fan motor, external fan motor, compressor and electric heater stop operations, guide louver stops and present location.	1. Bad contact of DC motor feedback terminal; 2. Bad contact of DC motor control end; 3. Fan motor is stalling; 4. Motor malfunction; 5. Malfunction of mainboard rev detecting circuit
38		H7			OFF 3S and blink 7 times				During cooling and drying operation, compressor will stop while indoor fan operate; During heating operation, the complete unit will stop operation.	Refer to the malfunction analysis (IPM protection, loss of synchronism protection and overcurrent protection of phase current for compressor.
39	PFC protection	HC			OFF 3S and blink 6 times	OFF 3S and blink 14 times			During cooling and drying operation, compressor will stop while indoor fan operate; During heating operation, the complete unit will stop operation.	Refer to the malfunction analysis (IPM protection, loss of synchronism protection and overcurrent protection of phase current for compressor.
40	Outdoor DC fan motor malfunction	L3	OFF 3S and blink 23 times				OFF 3S and blink 14 times		Outdoor DC fan motor malfunction lead to compressor stop operation.	DC fan motor malfunction or system blocked or the connector loosed



# Fault Displays

## 9,000 and 12,000 btuh units

No.	Malfunction Name	Display Method of Indoor Unit			Display Method of Outdoor Unit			A/C Status	Possible Causes	
		Dual-8 Code Display	Indicator Display (during blinking, ON 0.5s and OFF 0.5s)			Indicator has 3 kinds of display status and during blinking, ON 0.5s and OFF 0.5s				
			Operation Indicator	Cool Indicator	Heating Indicator	Yellow Indicator	Red Indicator			Green Indicator
41	Power protection	L9	OFF 3S and blink 20 times			OFF 3S and blink 9 times			Compressor stop operation and Outdoor fan motor will stop 30S later, 3 minutes later fan motor and compressor will restart	To protect the electrical components when detect high power
42	Indoor unit and outdoor unit doesn't match	LP	OFF 3S and blink 19 times			OFF 3S and blink 16 times			Compressor and outdoor fan motor can't work	Indoor unit and outdoor unit doesn't match
43	Failure start-up	LC			OFF 3S and blink 11 times				During cooling and drying operation, compressor will stop while indoor fan operate; During heating operations, the complete unit will stop operation.	Refer to the malfunction analysis
44	Malfunction of phase current detection circuit for compressor	U1			OFF 3S and blink 13 times				During cooling and drying operation, compressor will stop while indoor fan will operate; During heating operation, the complete unit will stop	Replace outdoor control panel AP1
45	Malfunction of voltage dropping for DC bus-bar	U3			OFF 3S and blink 20 times				During cooling and drying operation, compressor will stop while indoor fan will operate; During heating operation, the complete unit will stop	Supply voltage is unstable
46	Malfunction of complete units current detection	U5		OFF 3S and blink 13 times					During cooling and drying operation, compressor will stop while indoor fan will operate; During heating operation, the complete unit will stop	Theres circuit malfunction on outdoor units control panel AP1. Please replace the outdoor unit control panel AP1.

# Fault Displays

## 9,000 and 12,000 btuh units

No.	Malfunction Name	Display Method of Indoor Unit			Display Method of Outdoor Unit			A/C Status	Possible Causes	
		Dual-8 Code Display	Indicator Display (during blinking, ON 0.5s and OFF 0.5s)			Indicator has 3 kinds of display status and during blinking, ON 0.5s and OFF 0.5s				
			Operation Indicator	Cool Indicator	Heating Indicator	Yellow Indicator	Red Indicator			Green Indicator
47	The four-way valve is abnormal	U7		OFF 3S and blink 20 times					If this malfunction occurs during heating operation, the complete unit will stop operation	1. Supply voltage is lower than AC175V; 2. Wiring terminal 4V is loosened or broken, 3. 4V is damaged, please replace 4V
48	Zero-crossing malfunction of outdoor unit	U9	OFF 3S and blink 18 times						During cooling operation, compressor will stop while indoor fan will operate; during heating, the complete unit will stop operation.	Replace outdoor control panel AP1
49	Frequency limiting (power)						OFF 3S and blink 13 times			
50	Compressor running						OFF 3S and blink once			
51	The temperature for turning on the unit is reached						OFF 3S and blink 8 times			
52	Frequency limiting (module temperature)						OFF 3S and blink 11 times			
53	Normal							OFF 0.5S and blink once		
54	Defrosting				OFF 3S and blink once (during	OFF 0.5S and blink twice			Defrosting will occur in heating mode. Compressor will operate while indoor fan will stop operation.	It's the normal state.

# Fault Displays

9,000 and 12,000 btuh units

If malfunction occurs, corresponding code will display and the unit will resume normal until protection or malfunction disappears.

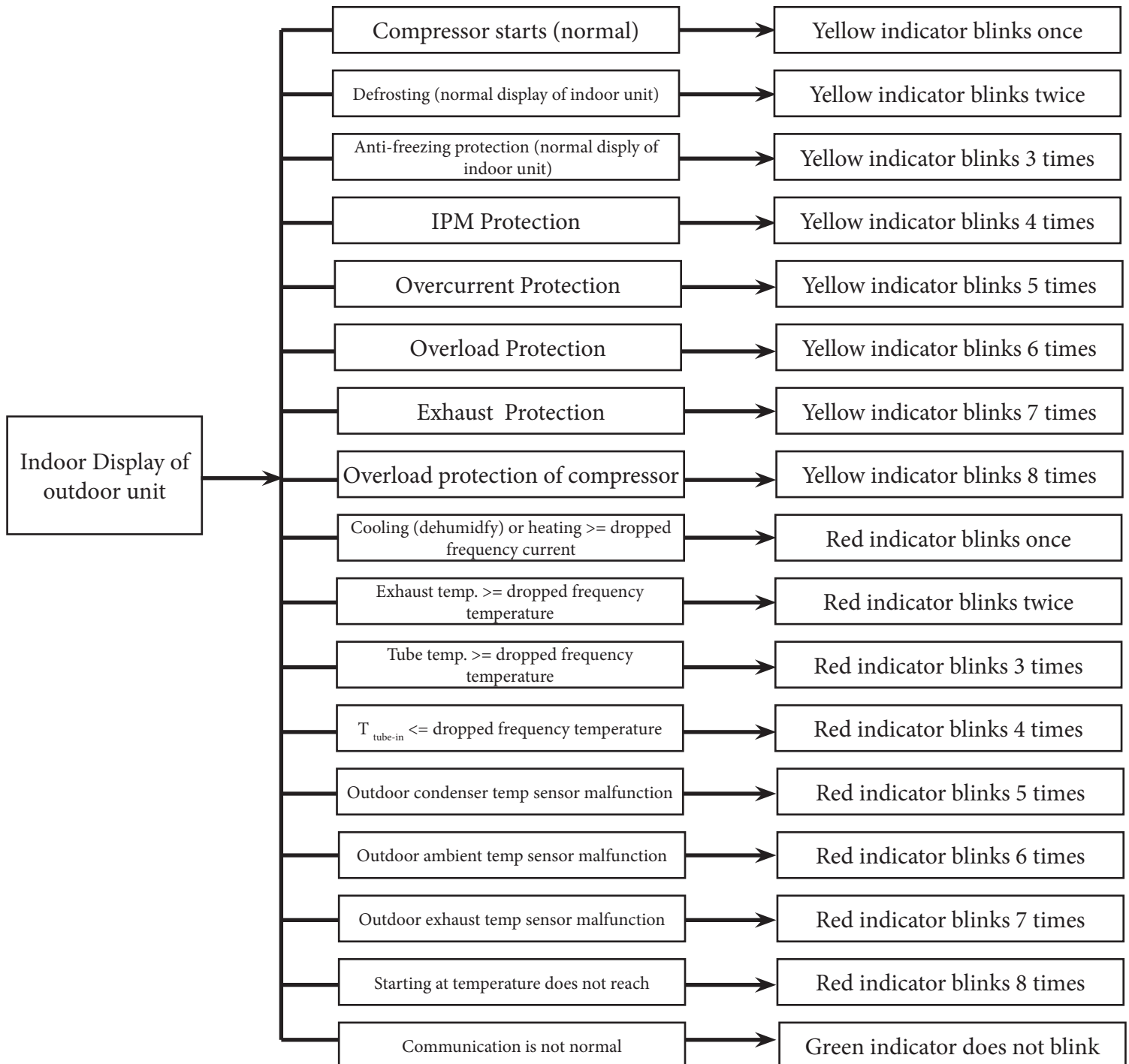

# Fault Displays

## 18,000 and 24,000 btuh units

Malfunction Name	Indoor Unit Displaying Method				Outdoor Unit Display (LED)				A/C Status	Malfunctions
	Dual-8 Code Display	Indicator Display (during blinking, ON 0.5s and OFF 0.5s)			Indicator has 3 kinds of display status and during blinking, ON 0.5s and OFF 0.5s					
		Running LED	Cooling LED	Heating LED	D40/D5	D41/D6	D42/D16	D43/D30		
High pressure protection of system	D1	OFF 3s and blink once			□	☆	☆	☆	During cooling and drying operation, except indoor fan operates, all loads stop operation. During heating operation the complete stops	Possible reasons: 1. Refrigerant was superabundant; 2. Poor heat exchange (including filth blockage of heat exchanger and bad radiating environment); Ambient temperature is too high.
Anti-freezing protection	E2	OFF 3s and blink twice			■	□	■	□	During cooling and drying operation, compressor and outdoor fan stop while indoor fan operates	1. Poor air return in indoor unit, 2. Fan speed is abnormal, 3. Evaporator is dirty
High discharge temperature protection of compressor	D4	OFF 3s and blink 4 times			■	□	■	☆	During cooling and drying operation, compressor and outdoor fan stop while indoor fan operates. During heating operation, all loads stop	Please refer to the malfunction analysis (discharge protection overload)
Overcurrent protection	E5	OFF 3s and blink 5 times			□	■	☆	□	During cooling and drying operation, compressor and outdoor fan stop while indoor fan operates. During heating operation, all loads stop	1. Supply voltage is unstable, 2. Supply voltage is too low and load is too high, 3. Evaporator is dirty

- = OFF
- = Illuminated
- ☆ = Blink

# Fault Displays

## 18,000 and 24,000 btuh units

Malfunction Name	Indoor Unit Displaying Method				Outdoor Unit Display (LED)				A/C Status	Malfunctions
	Dual-8 Code Display	Indicator Display (during blinking, ON 0.5s and OFF 0.5s)			Indicator has 3 kinds of display status and during blinking, ON 0.5s and OFF 0.5s					
		Running LED	Cooling LED	Heating LED	D40/D5	D41/D6	D42/D16	D43/D30		
Communication Malfunction	E6	OFF 3s and blink 6 times			□	□	□	☆	During cooling and drying operation, compressor and outdoor fan stop while indoor fan operates. During heating operation, all loads stop	Refer to the corresponding malfunction analysis
Circuit PG motor (indoor fan) has circuit malfunction by zero cross detection	U8	OFF 3s and blink 17 times							Operation of remote controller or control panel is available, but the unit wont act	Control board is damaged.
PG motor (indoor fan motor) does not operate	H6	OFF 3s and blink 11 times							The complete unit will stop operation	Poor connection for PGF in circuit diagram, Malfunction of indoor units control panel AP1, Malfunction of indoor units motor M1
High temperature resistant protection	E8	OFF 3s and blink 8 times			■	□	■	■	During cooling and drying operation, compressor and outdoor fan stop while indoor fan operates. During heating operation, all loads stop	Refer to the corresponding malfunction analysis

- = OFF
- = Illuminated
- ☆ = Blink

# Fault Displays

## 18,000 and 24,000 btuh units

Malfunction Name	Indoor Unit Displaying Method			Outdoor Unit Display (LED)				A/C Status	Malfunctions	
	Dual-8 Code Display	Indicator Display (during blinking, ON 0.5s and OFF 0.5s)			Indicator has 3 kinds of display status and during blinking, ON 0.5s and OFF 0.5s					
		Running LED	Cooling LED	Heating LED	D40/D5	D41/D6	D42/D16			D43/D30
Malfunction protection of jumper cap	C5	OFF 3s and blink 15 times							The complete unit will stop operation	Poor connection for the jumper cap on indoor units, control panel AP1, please reinsert or replace the jumper cap
Indoor ambient temperature sensor is open/short circuit	F1		OFF 3s and blink once						During cooling and drying operation, indoor unit operates while other loads will stop during heating operation, the complete unit will stop	1. Room temperature sensor hasn't been connected well with indoor units control panel AP1 (refer to the wiring diagram for indoor unit), 2. Room temperature sensor is damaged (please refer to the resistance table of temperature sensor)
Indoor evaporator temperature sensor is open/short circuited	F2		OFF 3s and blink twice						During cooling and drying operation, indoor unit will operate while other loads will stop; During heating operation, the complete unit will stop operation	1. Room temperature sensor hasn't been connected well with indoor units control panel AP1 (refer to the wiring diagram for indoor unit) 2. Room temperature sensor is damaged (please refer to the resistance table of temperature sensor)
Outdoor ambient temperature sensor is open/short circuited	F3		OFF 3s and blink 3 times		□	□	☆	■	During cooling and drying operating, compressor stops while indoor fan operates; During heating operation, the complete unit will stop operation	Outdoor temperature sensor hasn't been connected well or is damaged. Please check it by referring to the resistance table for the temperature sensor.

□ = OFF

■ = Illuminated

☆ = Blink

# Fault Displays

## 18,000 and 24,000 btuh units

Malfunction Name	Indoor Unit Displaying Method			Outdoor Unit Display (LED)				A/C Status	Malfunctions	
	Dual-8 Code Display	Indicator Display (during blinking, ON 0.5s and OFF 0.5s)			Indicator has 3 kinds of display status and during blinking, ON 0.5s and OFF 0.5s					
		Running LED	Cooling LED	Heating LED	D40/D5	D41/D6	D42/D16			D43/D30
Outdoor condenser temperature sensor is open/ short circuited	F4		OFF 3s and blink 4 times		□	□	☆	□	During cooling and drying operating, compressor stops while indoor fan operates; During heating operation, the complete unit will stop operation	Outdoor temperature sensor hasn't been connected well or is damaged. Please check it by referring to the resistance table for the temperature sensor.
Outdoor condenser temperature sensor is open/ short circuited	F5		OFF 3s and blink 5 times		□	□	☆	☆	During cooling and drying operation, compressor will stop after operating for about 3 mins, while indoor fan will operate; During heating operation, the complete unit will stop after operating for about 3 mins	1. Outdoor temperature sensor hasn't been connected well or is damaged. Please check it by referring to the resistance table for temperature sensor. 2. The head of temperature sensor hasn't been inserted into the copper tube
Limit/decrease frequency due to overload	F6		OFF 3s and blink 6 times		■	□	☆	☆	All loads operate normally, while operating frequency for compressor is decreased	Refer to the malfunction analysis (overload, high temperature resistant)
Decrease frequency due to overcurrent	F8		OFF 3s and blink 8 times		■	■	□	■	All loads operate normally, while operating frequency for compressor is decreased	The input supply voltage is too low, system pressure is too high and overload

- = OFF
- = Illuminated
- ☆ = Blink

# Fault Displays

## 18,000 and 24,000 btuh units

Malfunction Name	Indoor Unit Displaying Method			Outdoor Unit Display (LED)				A/C Status	Malfunctions	
	Dual-8 Code Display	Indicator Display (during blinking, ON 0.5s and OFF 0.5s)			Indicator has 3 kinds of display status and during blinking, ON 0.5s and OFF 0.5s					
		Running LED	Cooling LED	Heating LED	D40/D5	D41/D6	D42/D16			D43/D30
Decrease frequency due to high air discharge	F9		OFF 3s and blink 9 times		■	■	□	□	All loads operate normally, while operating frequency for compressor is decreased	Overload or temperature is too high, refrigerant is insufficient, Malfunction of electric expansion valve (EEV)
Voltage for DC bus-bar is too high	PH		OFF 3s and blink 11 times		□	■	□	☆	During cooling and drying operation, compressor will stop while indoor fan will operate; During heating operating the complete unit will stop operation	1. Measure the voltage of position L and N on wiring board (XT), if the voltage is higher than 265VAC, turn on the unit after the supply voltage is increased to the normal range. 2. If the AC input is normal measure the voltage of electrolytic capacitor C on control panel (AP1), if its normal, theres malfunction for the circuit, please replace the control panel (AP1)
Malfunction of complete units current detection	U5		OFF 3s and blink 13 times		□	■	☆	■	During cooling and drying operating, the compressor will stop while indoor fan will operate; During heating operation the complete unit will stop operating	Theres circuit malfunction on outdoor units control panel AP1, please replace the outdoor units control panel AP1

- = OFF
- = Illuminated
- ☆ = Blink



# Fault Displays

## 18,000 and 24,000 btuh units

Malfunction Name	Indoor Unit Displaying Method			Outdoor Unit Display (LED)				A/C Status	Malfunctions	
	Dual-8 Code Display	Indicator Display (during blinking, ON 0.5s and OFF 0.5s)			Indicator has 3 kinds of display status and during blinking, ON 0.5s and OFF 0.5s					
		Running LED	Cooling LED	Heating LED	D40/D5	D41/D6	D42/D16			D43/D30
Malfunction of complete units current detection	U5		OFF 3s and blink 13 times		□	■	☆	■	During cooling and drying operating, the compressor will stop while indoor fan will operate; During heating operation the complete unit will stop operating	There's circuit malfunction on outdoor units control panel AP1, please replace the outdoor units control panel AP1
Overcurrent protection of phase current for compressor	P5		OFF 3s and blink 15 times		□	☆	□	□	During cooling and drying operating, the compressor will stop while indoor fan will operate; During heating operation the complete unit will stop operating	Refer to the malfunction analysis (IPM protection, loss of synchronism protection and overcurrent protection of phase current for compressor.
Defrosting	H1			OFF 3s and blink once					Defrosting will occur in heating mode. Compressor will operate while indoor fan will stop operation	It's the normal state
Static dedusting protection	H2			OFF 3s and blink twice					/	/
Overload protection for compressor	H3			OFF 3s and blink 3 times	□	☆	☆	□	During cooling and drying operation, compressor will stop while indoor fan will operate; During heating operation, the complete unit will stop operation.	1. Wiring terminal OVC-COMP is loosened. In normal state, the resistance for this terminal should be less than 1ohm 2. Refer to the malfunction analysis (discharge protection, overload)

- = OFF
- = Illuminated
- ☆ = Blink

# Fault Displays

## 18,000 and 24,000 btuh units

Malfunction Name	Indoor Unit Displaying Method			Outdoor Unit Display (LED)				A/C Status	Malfunctions	
	Dual-8 Code Display	Indicator Display (during blinking, ON 0.5s and OFF 0.5s)			Indicator has 3 kinds of display status and during blinking, ON 0.5s and OFF 0.5s					
		Running LED	Cooling LED	Heating LED	D40/D5	D41/D6	D42/D16			D43/D30
System is abnormal	H4			OFF 3s and blink 4 times	■	□	■	■	During cooling and drying operation, compressor will stop while indoor fan will operate; During heating operation, the complete unit will stop operation.	Refer to the malfunction analysis (overload, high temperature resistant)
IPM protection	H5			OFF 3s and blink 5 times	□	☆	□	■	During cooling and drying operation, compressor will stop while indoor fan will operate; During heating operation, the complete unit will stop operation.	Refer to the malfunction analysis (IPM protection, loss of synchronism protection and overcurrent protection of phase current for compressor)
PFC protection	HC			OFF 3s and blink 6 times	□	■	☆	☆	During cooling and drying operation, compressor will stop while indoor fan will operate; During heating operation, the complete unit will stop operation.	Refer to the malfunction analysis
Desynchronizing of compressor	H7			OFF 3s and blink 7 times	o	Ɔ	n	Ɔ	During cooling and drying operation, compressor will stop while indoor fan will operate; During heating operation, the complete unit will stop operation.	Refer to the malfunction analysis (IPM protection, loss of synchronism protection and overcurrent protection of phase current for compressor)

- = OFF
- = Illuminated
- ☆ = Blink

# Fault Displays

## 18,000 and 24,000 btuh units

Malfunction Name	Indoor Unit Displaying Method			Outdoor Unit Display (LED)				A/C Status	Malfunctions	
	Dual-8 Code Display	Indicator Display (during blinking, ON 0.5s and OFF 0.5s)			Indicator has 3 kinds of display status and during blinking, ON 0.5s and OFF 0.5s					
		Running LED	Cooling LED	Heating LED	D40/D5	D41/D6	D42/D16			D43/D30
Decrease frequency due to high temperature resistant during heating operation	H0			OFF 3s and blink 10 times	■	□	☆	☆	All loads operate normally, while operation frequency for compressor is decreased	Refer to the malfunction analysis (overload, high temperature resistant)
Failure startup	LC			OFF 3s and blink 11 times	□	☆	□	☆	During cooling and drying operation, compressor will stop while indoor fan will operate; During heating operation, the complete unit will stop operation.	Refer to the malfunction analysis
Malfunction of phase current detection circuit for compressor	U1			OFF 3s and blink 13 times	□	☆	■	□	During cooling and drying operation, compressor will stop while indoor fan will operate; During heating operation, the complete unit will stop operation.	Replace outdoor control panel AP1
EEPROM malfunction	EE			OFF 3s and blink 15 times	□	□	□	■	During cooling and drying operation, compressor will stop while indoor fan will operate; During heating operation, the complete unit will stop	Replace outdoor control panel AP1
Charging malfunction of capacitor	PU			OFF 3s and blink 17 times	□	■	□	■	During cooling and drying operation, compressor will stop while indoor fan will operate; During heating operation, the complete unit will stop	Refer to the part three--charging malfunction analysis of capacitor

□ = OFF   ■ = Illuminated   ☆ = Blink

# Fault Displays

## 18,000 and 24,000 btuh units

Malfunction Name	Indoor Unit Displaying Method			Outdoor Unit Display (LED)				A/C Status	Malfunctions	
	Dual-8 Code Display	Indicator Display (during blinking, ON 0.5s and OFF 0.5s)			Indicator has 3 kinds of display status and during blinking, ON 0.5s and OFF 0.5s					
		Running LED	Cooling LED	Heating LED	D40/D5	D41/D6	D42/D16			D43/D30
Malfunction of module temperature sensor circuit	P7			OFF 3s and blink 18 times	□	□	■	☆	During cooling and drying operation, compressor will stop while indoor fan will operate; During heating operation, the complete unit will stop	Replace outdoor control panel AP1
Module high temperature protection	P8			OFF 3s and blink 19 times	■	□	☆	■	During cooling and drying operation, compressor will stop while indoor fan will operate; During heating operation, the complete unit will stop	After the complete unit is deenergized for 20 mins, check whether the thermal grease on IPM Module of outdoor control panel AP1 is sufficient and whether the radiator is inserted tightly. If its no use, please replace control panel AP1
Malfunction of voltage dropping for DC bus-bar	U3			OFF 3s and blink 20 times	□	■	■	■	During cooling and drying operation, compressor will stop while indoor fan will operate; During heating operation, the complete unit will stop	Supply voltage is unstable

- = OFF
- = Illuminated
- ☆ = Blink

# Fault Displays

## 18,000 and 24,000 btuh units

Malfunction Name	Indoor Unit Displaying Method			Outdoor Unit Display (LED)				A/C Status	Malfunctions	
	Dual-8 Code Display	Indicator Display (during blinking, ON 0.5s and OFF 0.5s)			Indicator has 3 kinds of display status and during blinking, ON 0.5s and OFF 0.5s					
		Running LED	Cooling LED	Heating LED	D40/D5	D41/D6	D42/D16			D43/D30
Voltage of DC bus-bar is too low	PL			OFF 3s and blink 21 times	□	■	■	□	During cooling and drying operation, compressor will stop while indoor fan will operate; During heating operation, the complete unit will stop	1. Measure the voltage of position L and N on wiring board (XT), if the voltage is higher than 150VAC, turn on the unit after the supply voltage is increased to the normal range. 2. If the AC input is normal, measure the voltage of electrolytic capacitor C on control panel (AP1), if its normal, theres malfunction for the circuit, please replace the control panel AP1
Limit/decrease frequency due to high temperature of module	EU				■	■	■	☆	All loads operate normally, while operation frequency for compressor is decreased	Discharging after the complete unit is de-energized for 20 mins, check whether the thermal grease on IPM Module of outdoor control panel AP1 is sufficient and whether the radiator is inserted tightly. If its no use, please replace control panel AP1
The four-way valve is abnormal	U7				■	□	☆	□	If this malfunction occurs during heating operation, the complete unit will drop operation	1. Supply voltage is lower than AC175V; 2. Wiring terminal 4V is loosened or broken; 3. 4V is damaged, please replace 4V

- = OFF
- = Illuminated
- ☆ = Blink

# Fault Displays

## 18,000 and 24,000 btuh units

Malfunction Name	Indoor Unit Displaying Method			Outdoor Unit Display (LED)				A/C Status	Malfunctions	
	Dual-8 Code Display	Indicator Display (during blinking, ON 0.5s and OFF 0.5s)			Indicator has 3 kinds of display status and during blinking, ON 0.5s and OFF 0.5s					
		Running LED	Cooling LED	Heating LED	D40/D5	D41/D6	D42/D16			D43/D30
Zero crossing malfunction of outdoor unit	U9				■	■	☆	□	During cooling operation, compressor will stop while indoor fan will operate; during heating the complete unit will stop operation	Replace outdoor control panel AP1
Limit/decrease frequency due to anti freezing	FH				■	■	■	□	All loads operate normally, while operation frequency for compressor is decreased	Poor air-return in indoor unit or fan speed is too low

- = OFF
- = Illuminated
- ☆ = Blink

# Troubleshooting 9,000 & 12,000 Units

## Indoor Fan does not Operate

Is the indoor control board fastened securely and wired correctly?  
Are the input voltages within 10% of rated value?

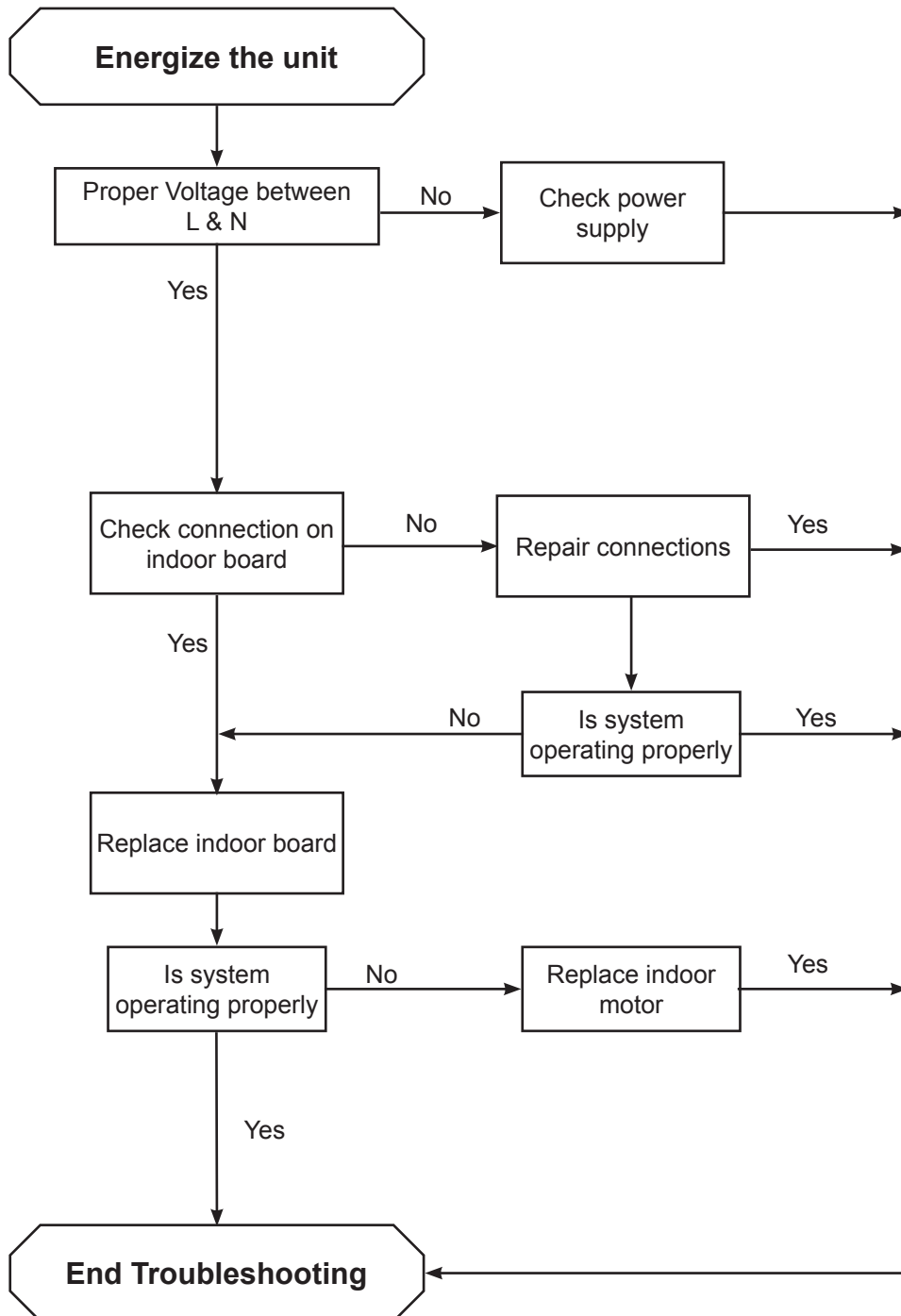

# Troubleshooting 9,000 & 12,000 Units

## Temperature Sensor Malfunction

### Temperature sensor malfunction

F1 & F2 will relate to indoor sensor faults  
F4 & F5 will relate to outdoor sensor faults

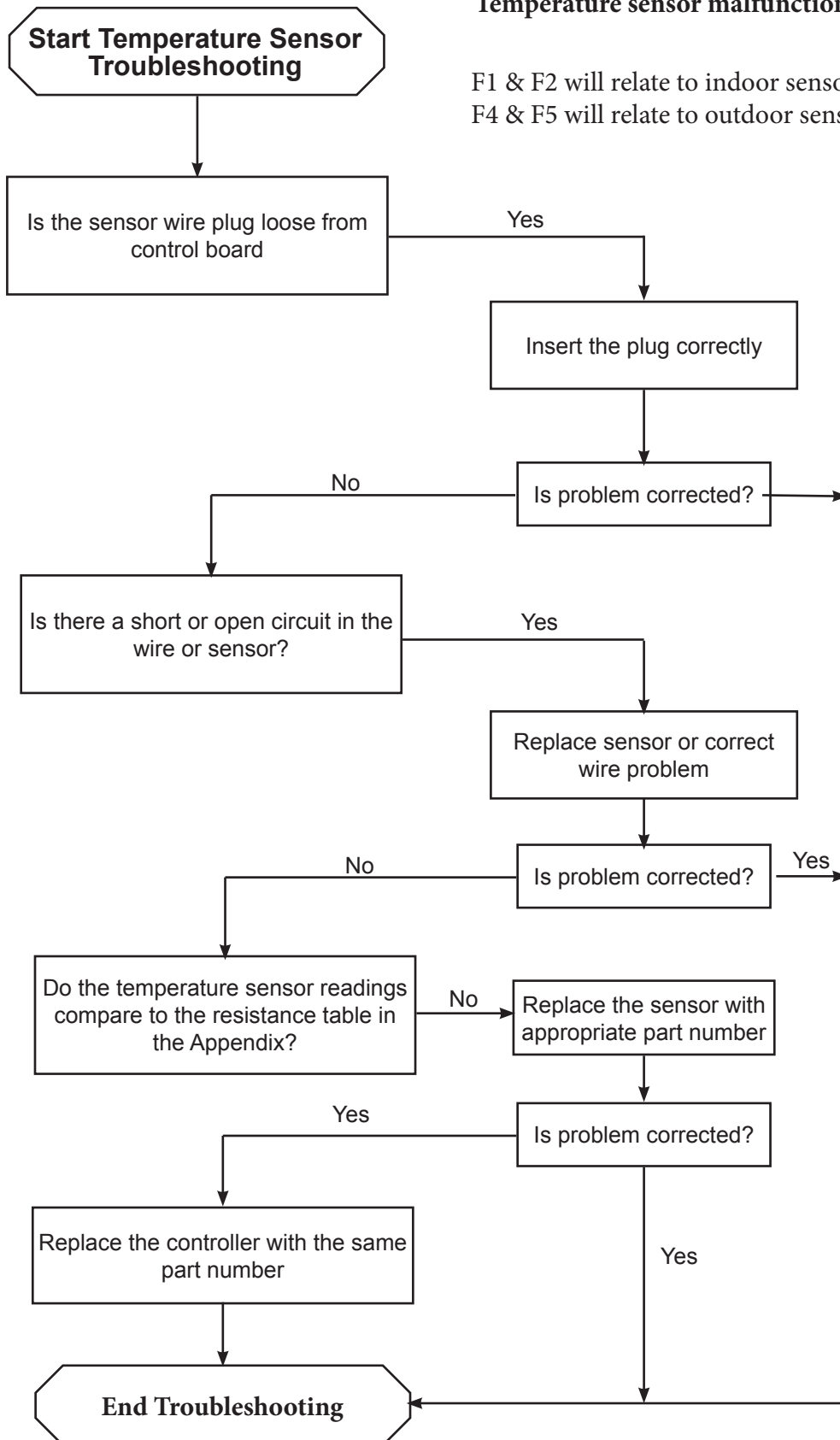



# Troubleshooting 9,000 & 12,000 Units

## Start Failure Malfunction

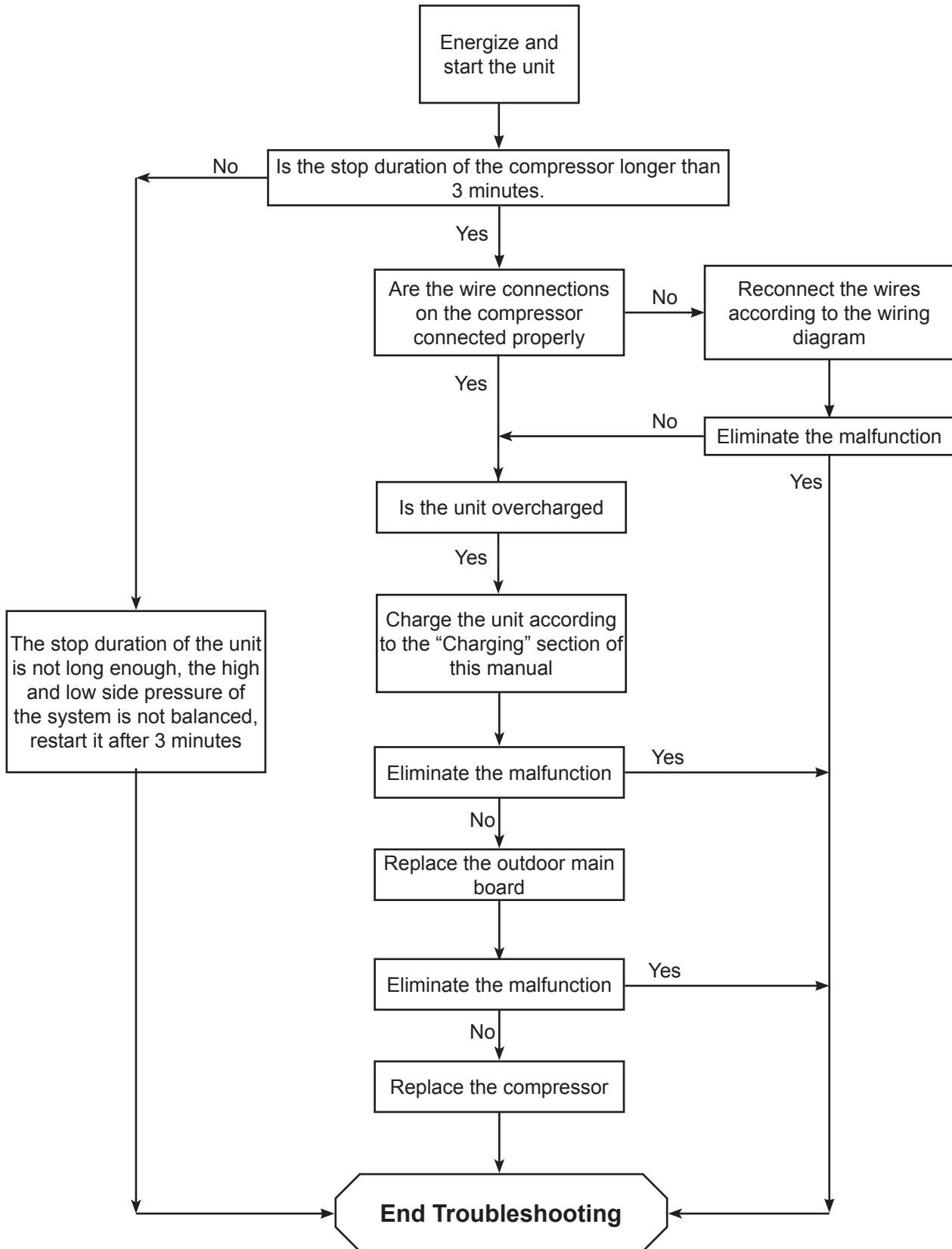

# Troubleshooting 9,000 & 12,000 Units

## Desynchronizing of Compressor after Unit is Started

H7



### Desynchronizing of compressor

#### **Status:**

During cooling mode, compressor will stop, indoor fan will run. Heating mode all units stop.

1. Check the resistance of the compressor terminals and connections to the compressor
2. Check for overcharge of refrigerant
3. Check for correct voltage
4. Check for dirty coils and filters

### ***Troubleshooting Procedure for Synchronizing Fault after Unit is Started***

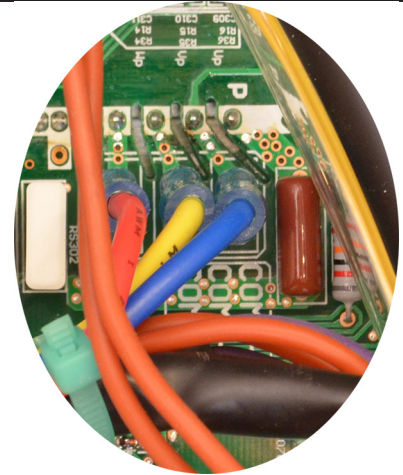
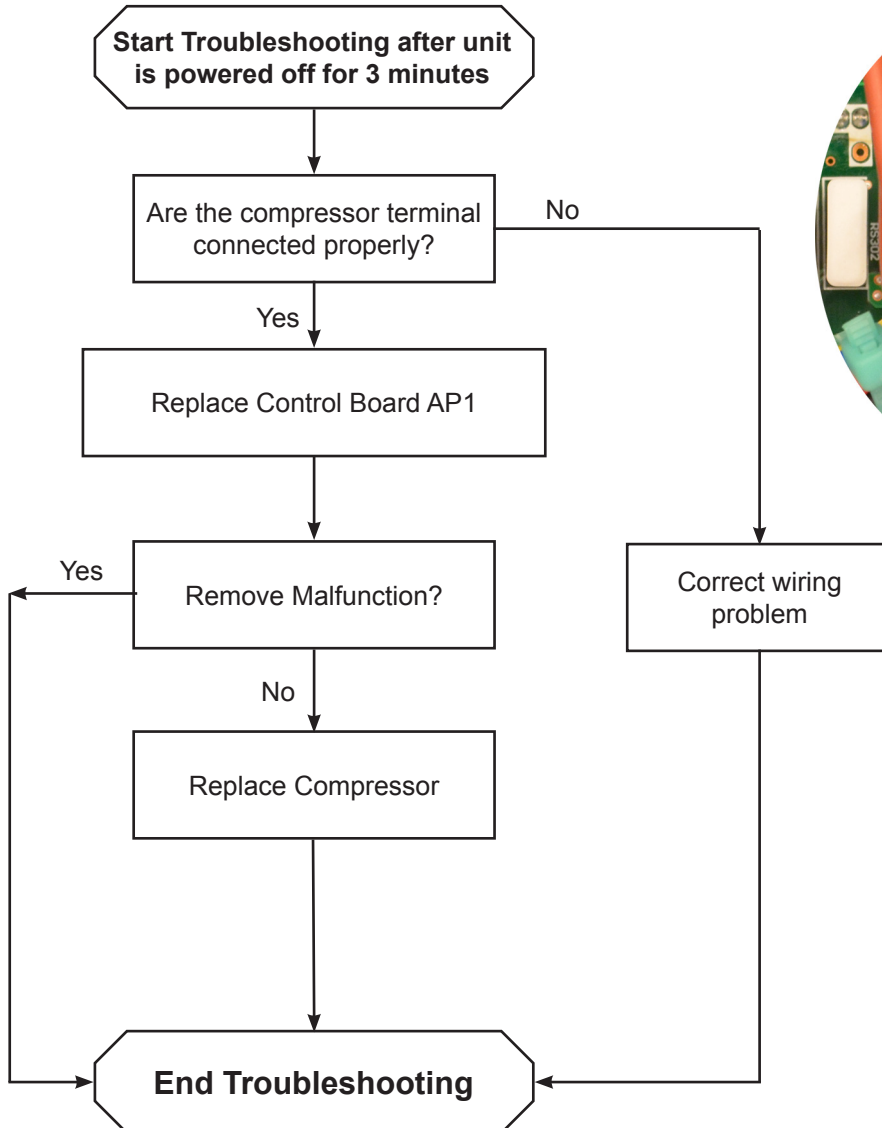

Compressor Wires

*Illustration is for reference only, actual model may vary.*

# Troubleshooting 9,000 & 12,000 Units

## Desynchronizing of Compressor During Operation

H7



### Desynchronizing of compressor

**Status:**

During cooling mode, compressor will stop, indoor fan will run. Heating mode all units stop.

1. Check the resistance of the compressor terminals and connections to the compressor
2. Check for overcharge of refrigerant
3. Check for correct voltage

### Troubleshooting Procedure for Synchronizing Fault During Operation

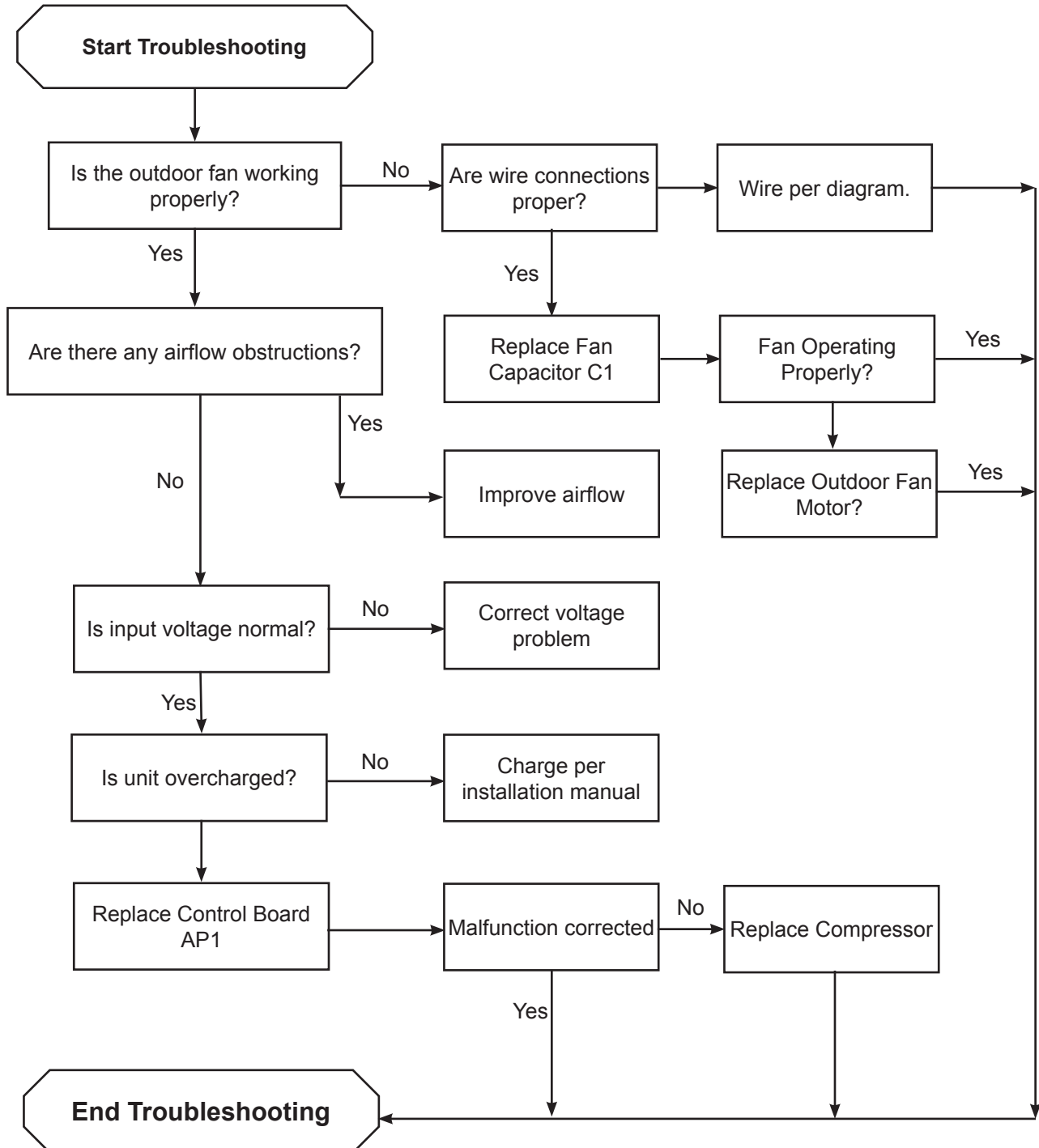

# Troubleshooting 9,000 & 12,000 Units

## Overload and Discharge Malfunction

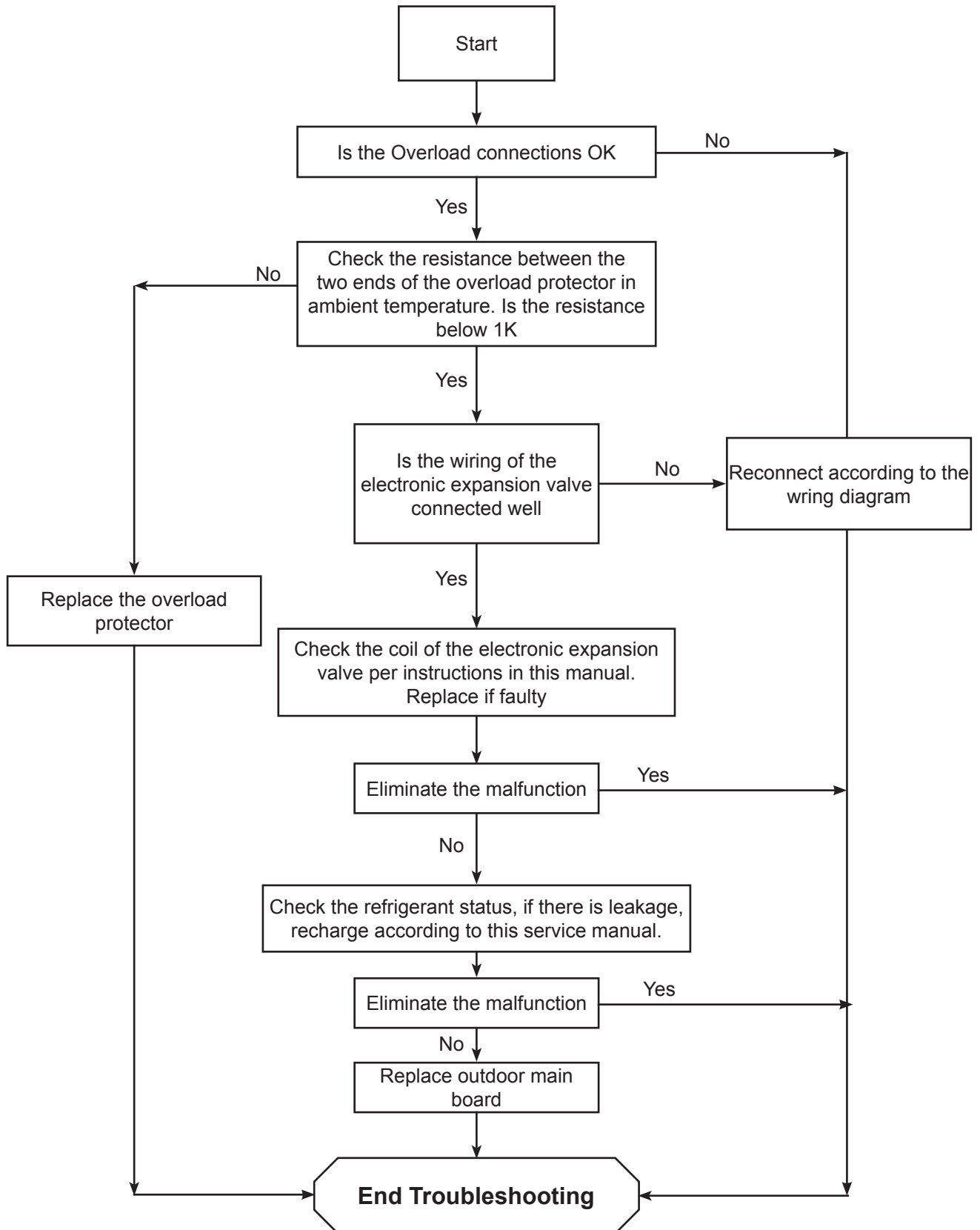

# Troubleshooting 9,000 & 12,000 Units

## Communication Failure

E6



### Communication Failure

#### **Status:**

Cooling operation, compressor stops while indoor fans runs. Heating operation, complete unit stops

1. Improper voltages
2. Mis-matched indoor and outdoor units
3. Improper wiring between indoor and outdoor units

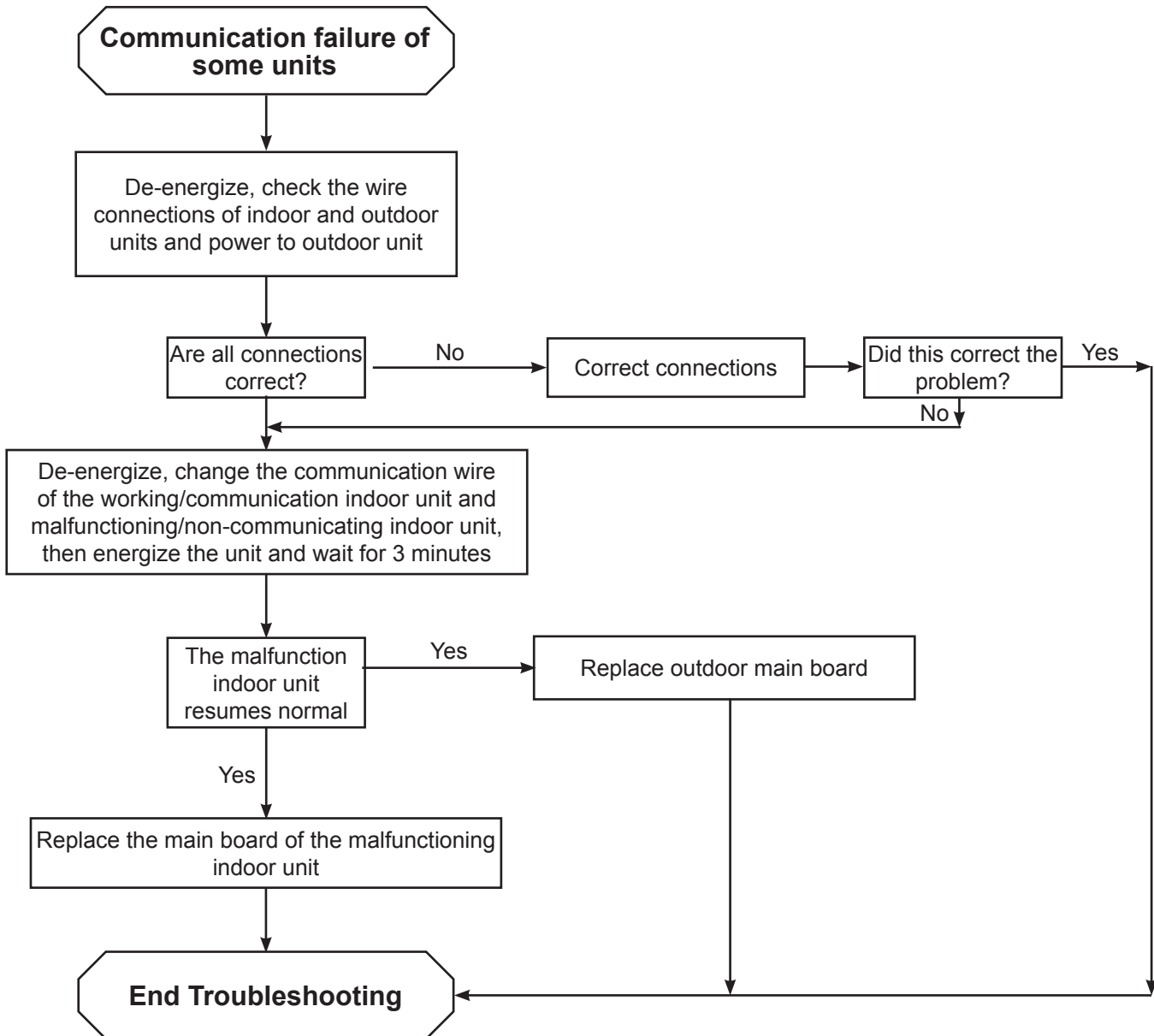

# Troubleshooting 18,000 & 24,000 Units

## Temperature sensor malfunction

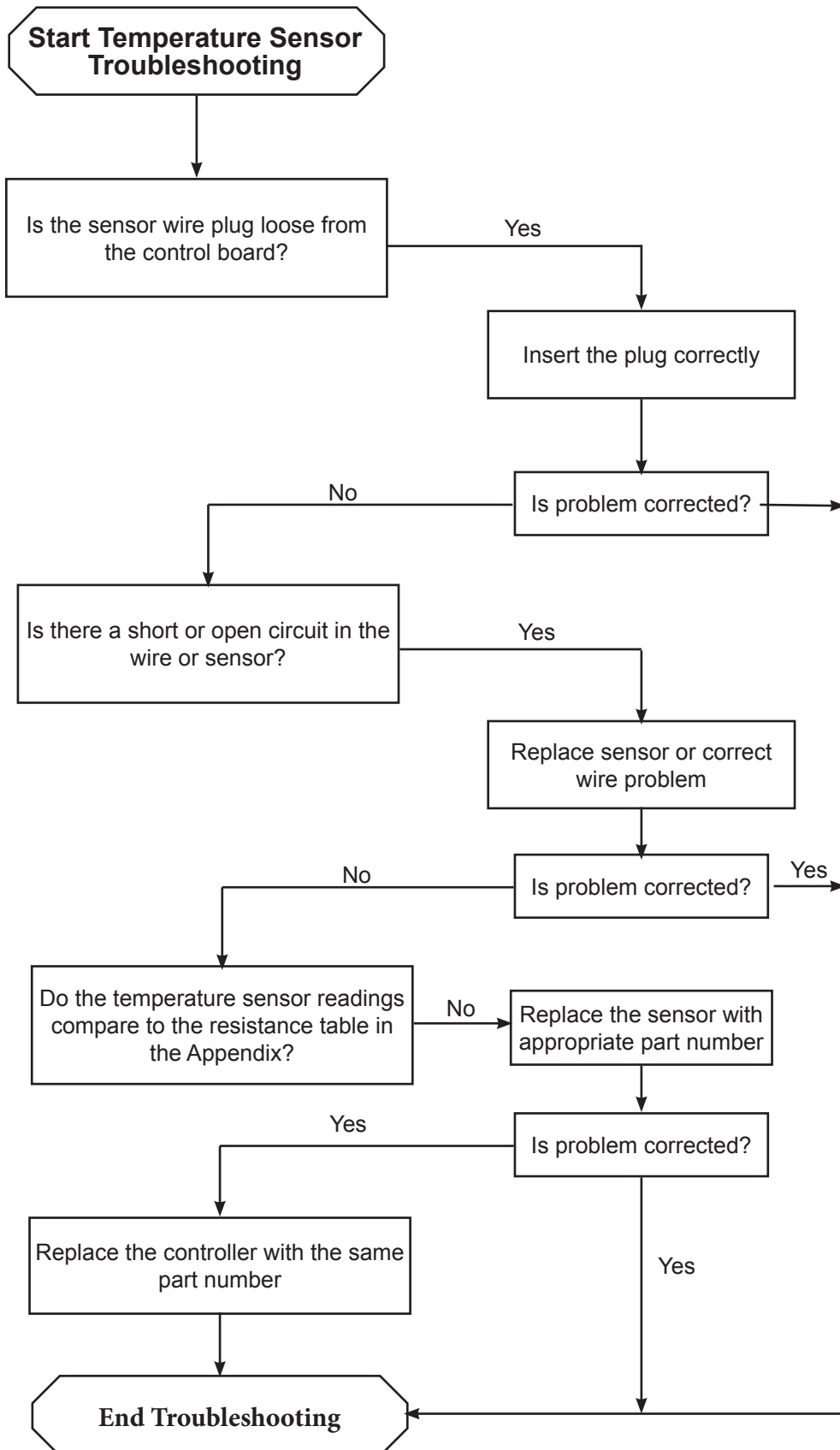

# Troubleshooting 18,000 & 24,000 Units

## Indoor fan does not operate



Possible causes:

1. Fan motor locked
2. The control or feedback terminal of PG not connected properly
3. Damaged motor
4. Main board malfunction

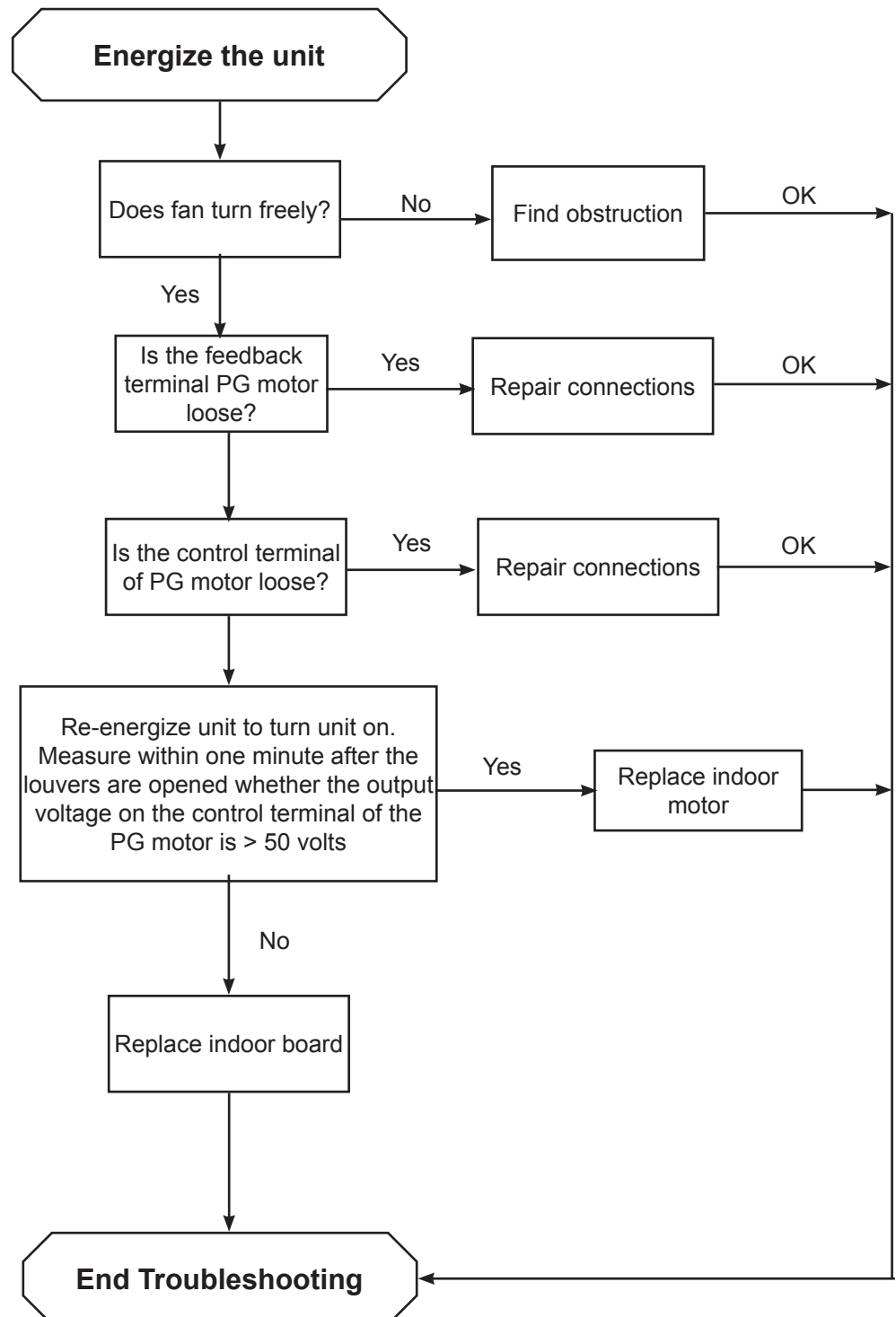

# Troubleshooting 18,000 & 24,000 Units

## Jumper Cap Malfunction

C5



### Jumper Cap Malfunction

**Status:**

Wireless remote will not send command to indoor unit.

1. No jumper cap inserted on board
2. Jumper cap not fully seated
3. Jumper cap damaged
4. Bad control board

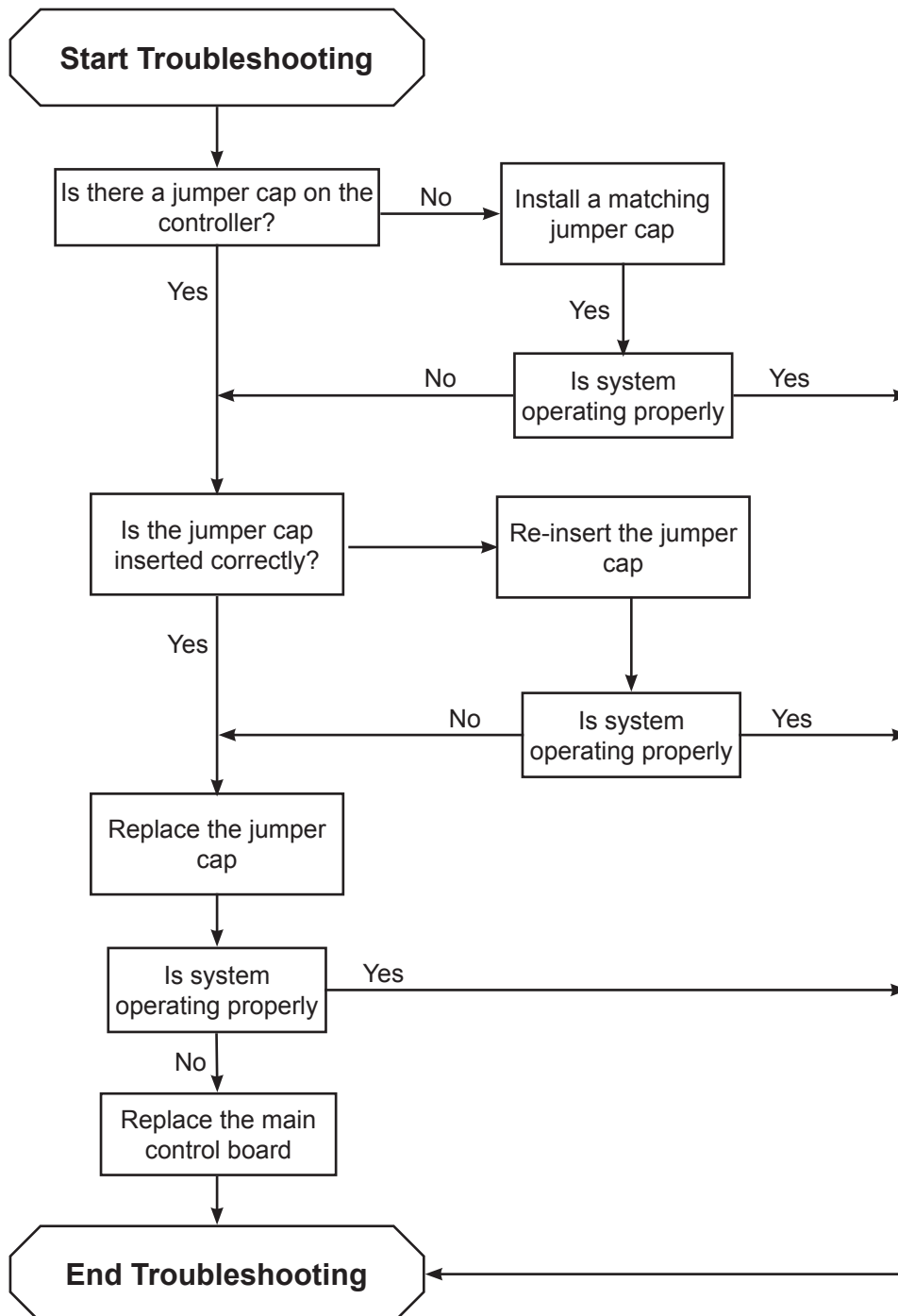



# Troubleshooting 18,000 & 24,000 Units

## Overcurrent Protection

E5



### Fault & Status

#### Overcurrent Protection

#### **Status:**

During cooling & dehumidifying, indoor unit operates while other functions stop; During heating operation, complete unit stops

### Possible Causes

1. Supply voltage is unstable
2. Supply voltage is too low
3. Coils are dirty
4. Improper refrigerant charge

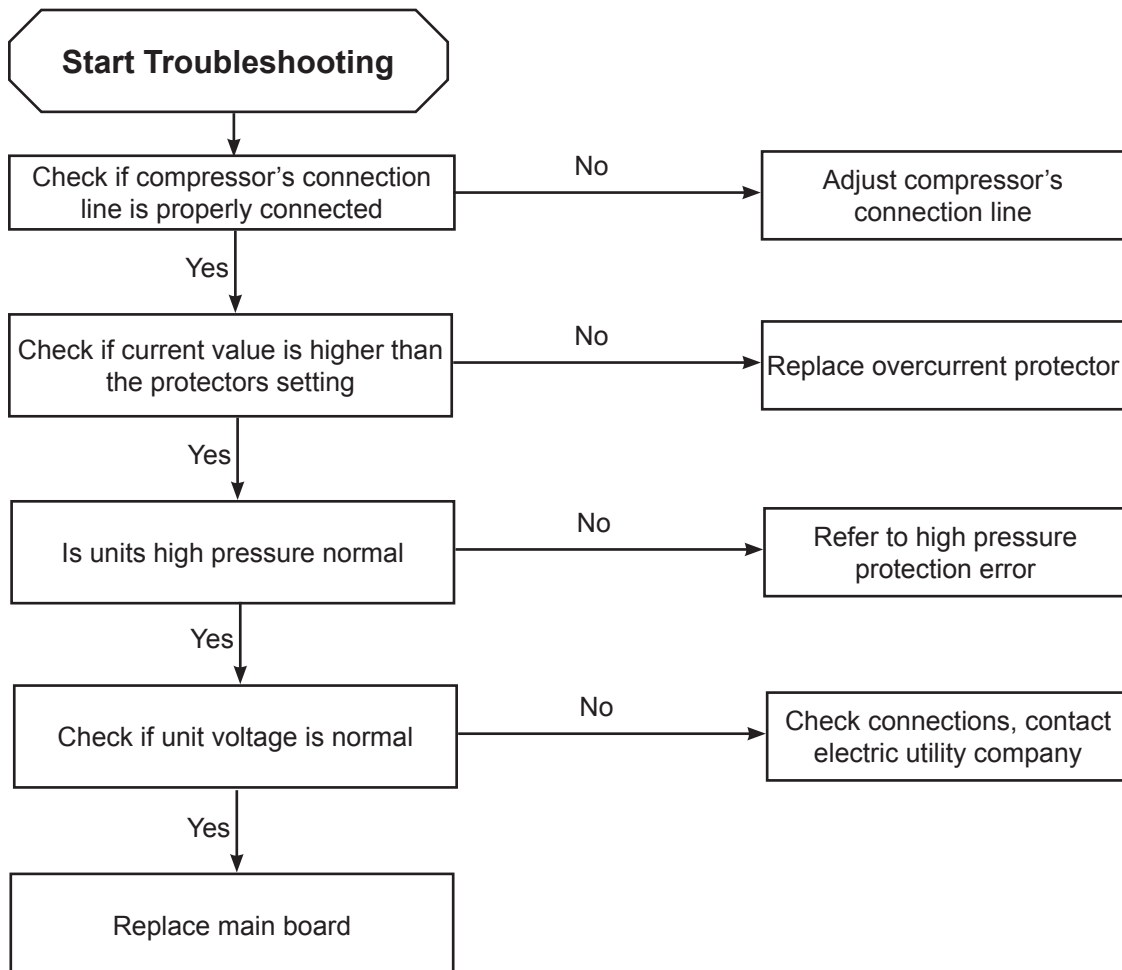

# Troubleshooting 18,000 & 24,000 Units

## Capacity Charging Malfunction

PU



### Charging Malfunction of Capacitor

**Status:**

During cooling mode, compressor will stop, indoor fan will run. Heating mode all units stop.

1. Improper input voltage
2. Poor connection on reactor
3. Reactor damaged
4. Bad AP1 control board

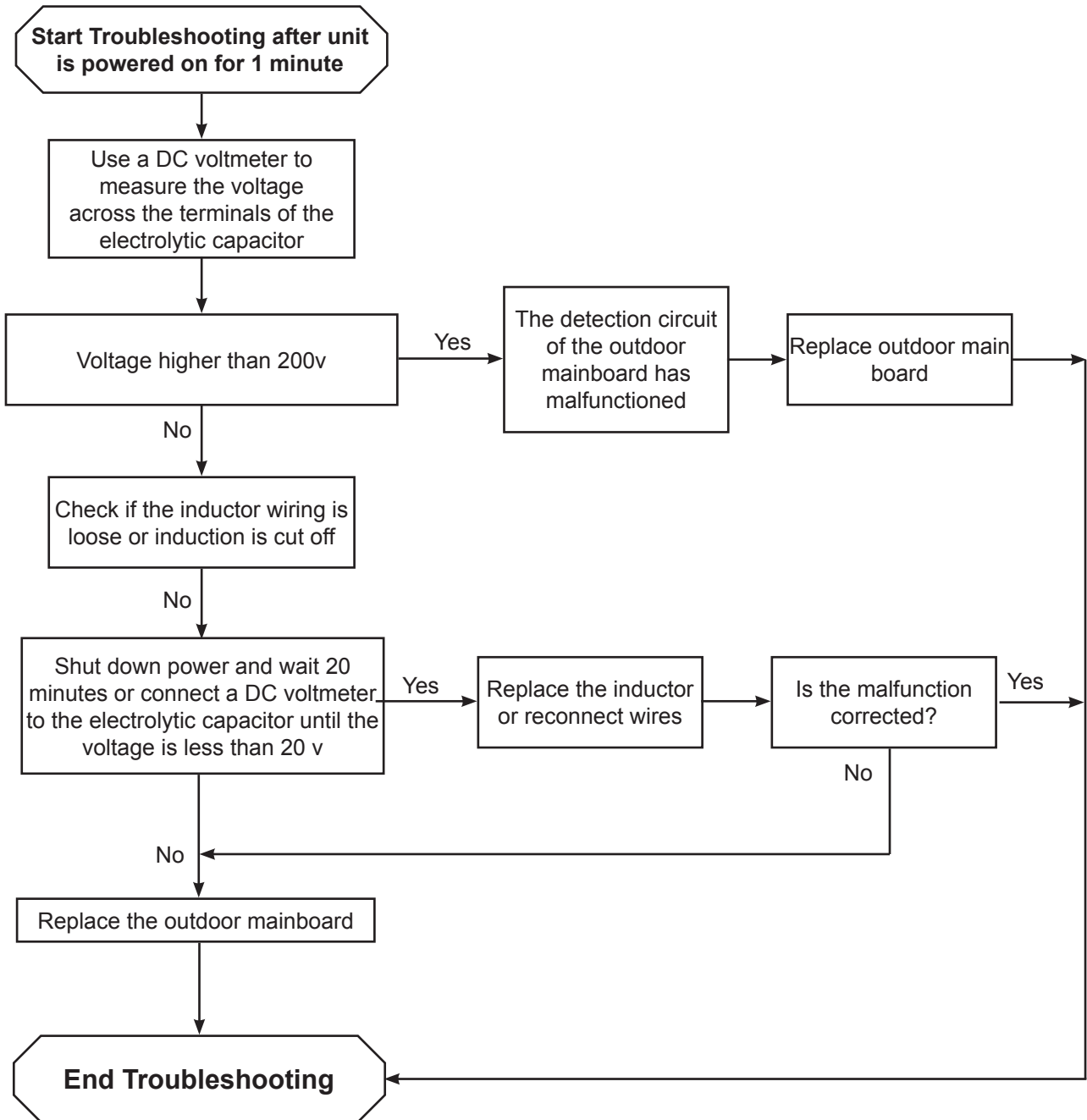

# Troubleshooting 18,000 & 24,000 Units

## IPM Protection Malfunction (unit will not run)

### Fault & Status

IPM Protection

**Status:**

During cooling mode, compressor will stop, indoor fan will run. Heating mode all units stop.

### Possible Causes

1. Dirty indoor and outdoor coils
2. Faulty indoor or outdoor fans
3. High system pressure
4. Over charge of refrigerant

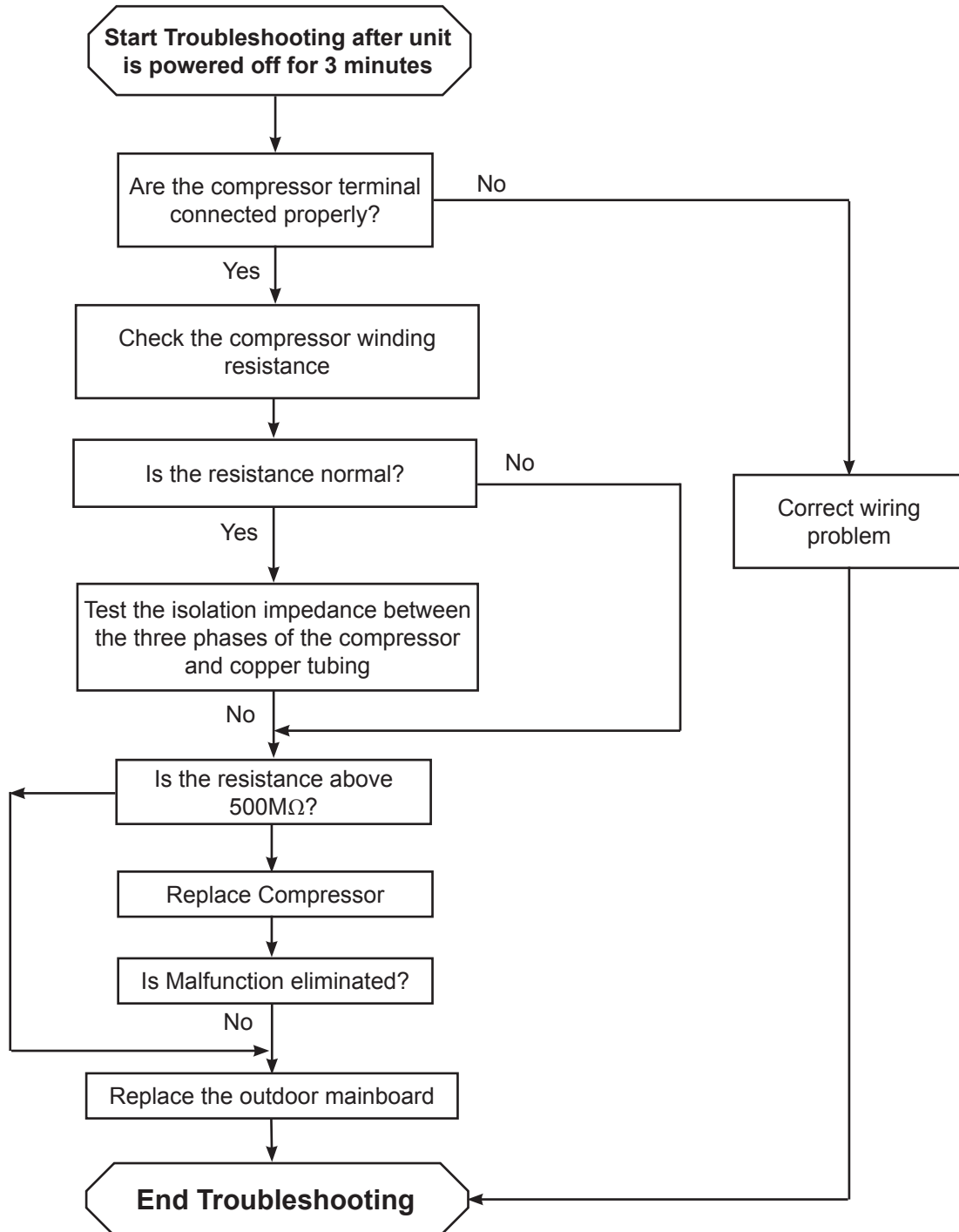

# Troubleshooting 18,000 & 24,000 Units

## Compressor Overload, Discharge Protection Malfunction

1. Check the resistance of the compressor terminals and connections to the compressor
2. Check for overcharge of refrigerant
3. Check for correct voltage
4. Check for dirty coils and filters

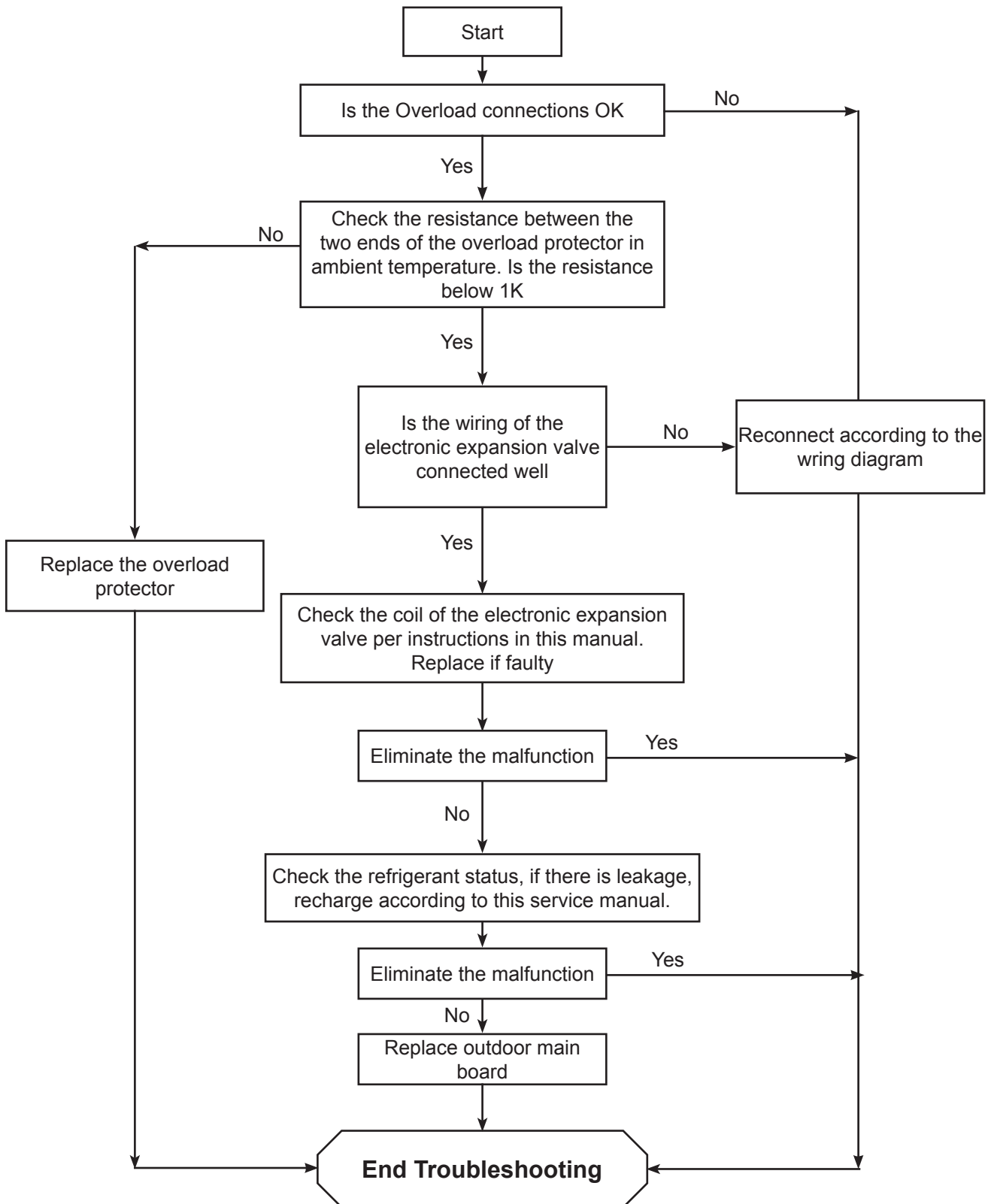

# Troubleshooting 18,000 & 24,000 Units

Desynchronize Malfunction, continued next page

H7



## Desynchronizing of compressor

### Status:

During cooling mode, compressor will stop, indoor fan will run. Heating mode all units stop.

1. Check the resistance of the compressor terminals and connections to the compressor
2. Check for overcharge of refrigerant
3. Check for correct voltage
4. Check for dirty coils and filters

### Troubleshooting Procedure for Synchronizing Fault after Unit is Started

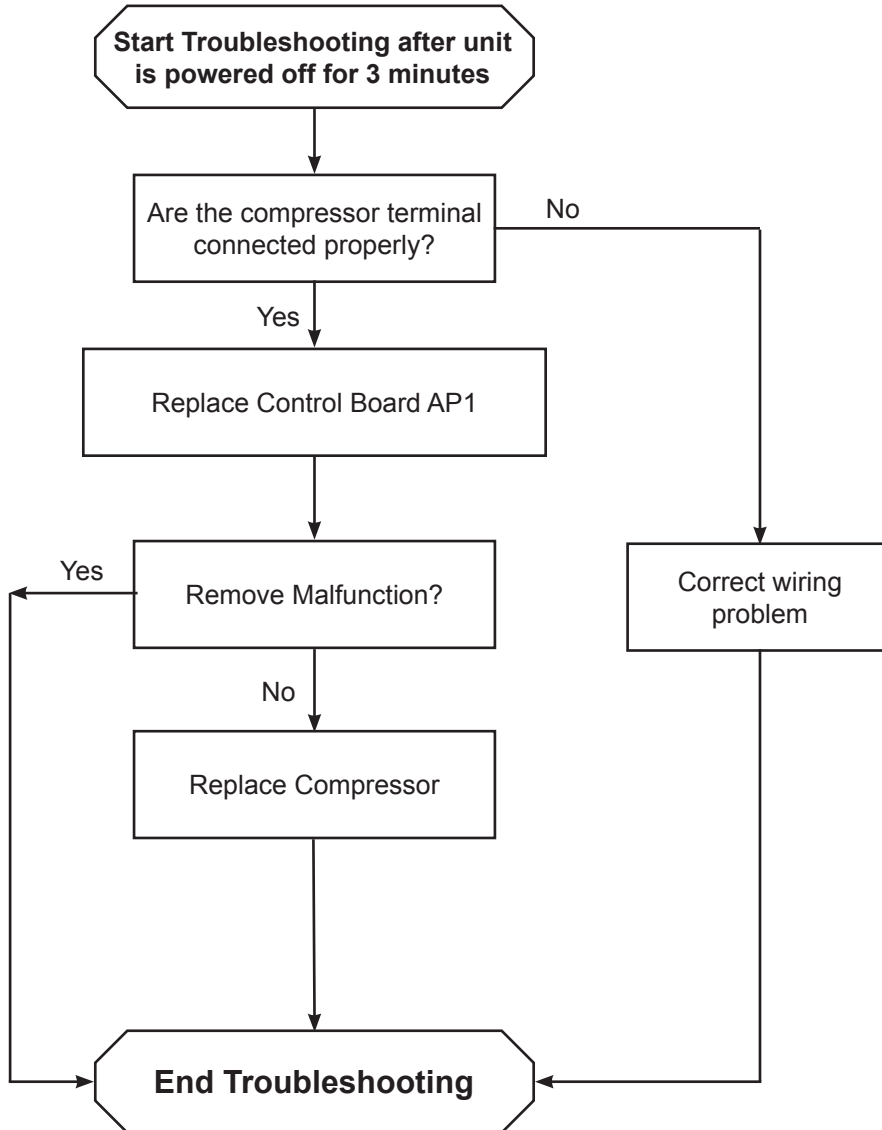

# Troubleshooting 18,000 & 24,000 Units

## Desynchronize Malfunction, continued

H7



### Desynchronizing of compressor

**Status:**

During cooling mode, compressor will stop, indoor fan will run. Heating mode all units stop.

1. Check the resistance of the compressor terminals and connections to the compressor
2. Check for overcharge of refrigerant
3. Check for correct voltage

### ***Troubleshooting Procedure for Synchronizing Fault During Operation***

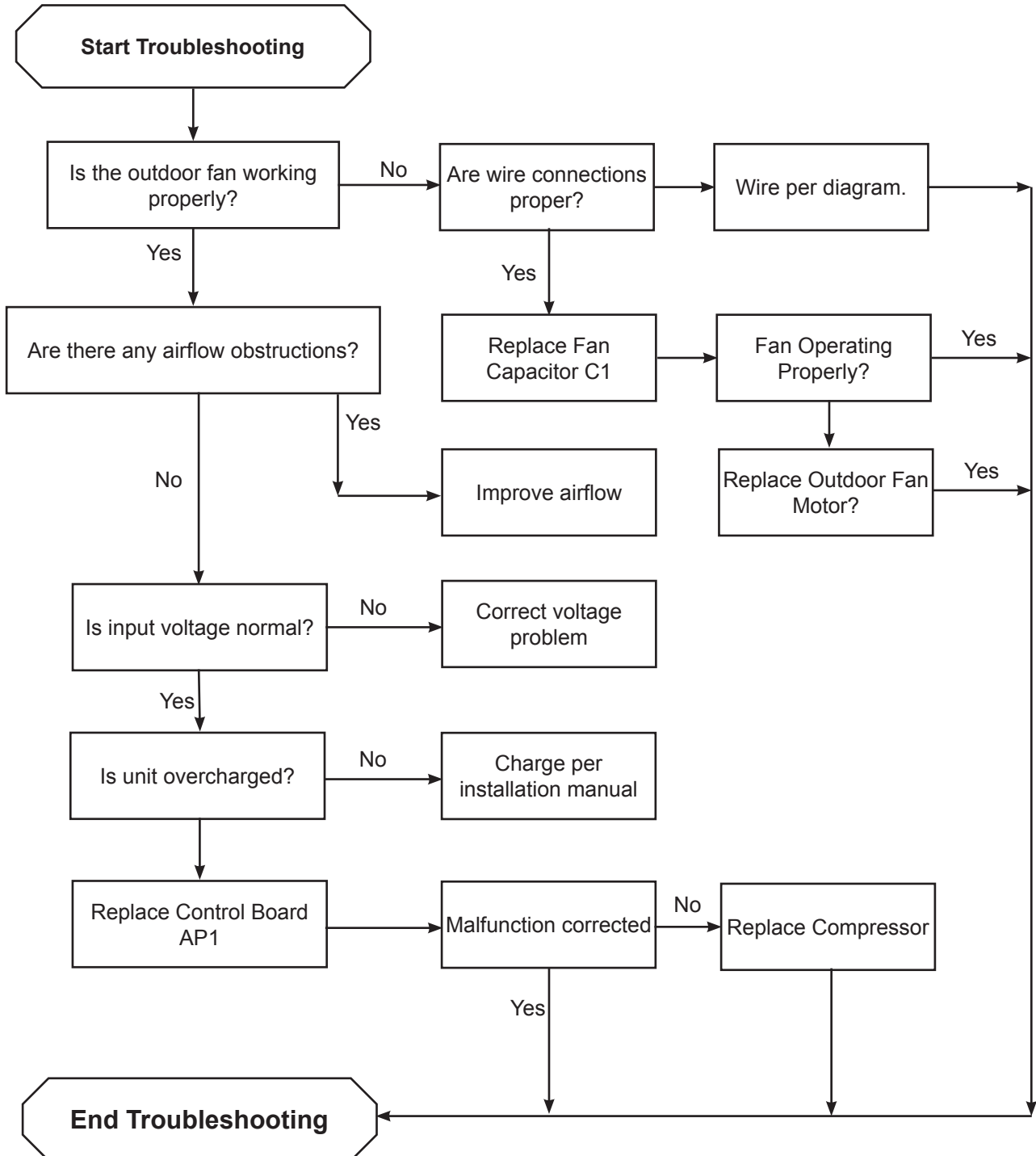

# Troubleshooting 18,000 & 24,000 Units

## Anti-High Temperature, Overload Protection

### High Discharge Temperature Protection of Compressor.

#### **Status:**

Cooling operation, compressor stops while indoor fans runs. Heating operation, complete unit stops

1. Is unit running in proper outdoor ambient range
2. Faulty outdoor temperature sensor
3. Refrigerant leak
4. Poor airflow of outdoor unit
5. Follow Troubleshooting procedure

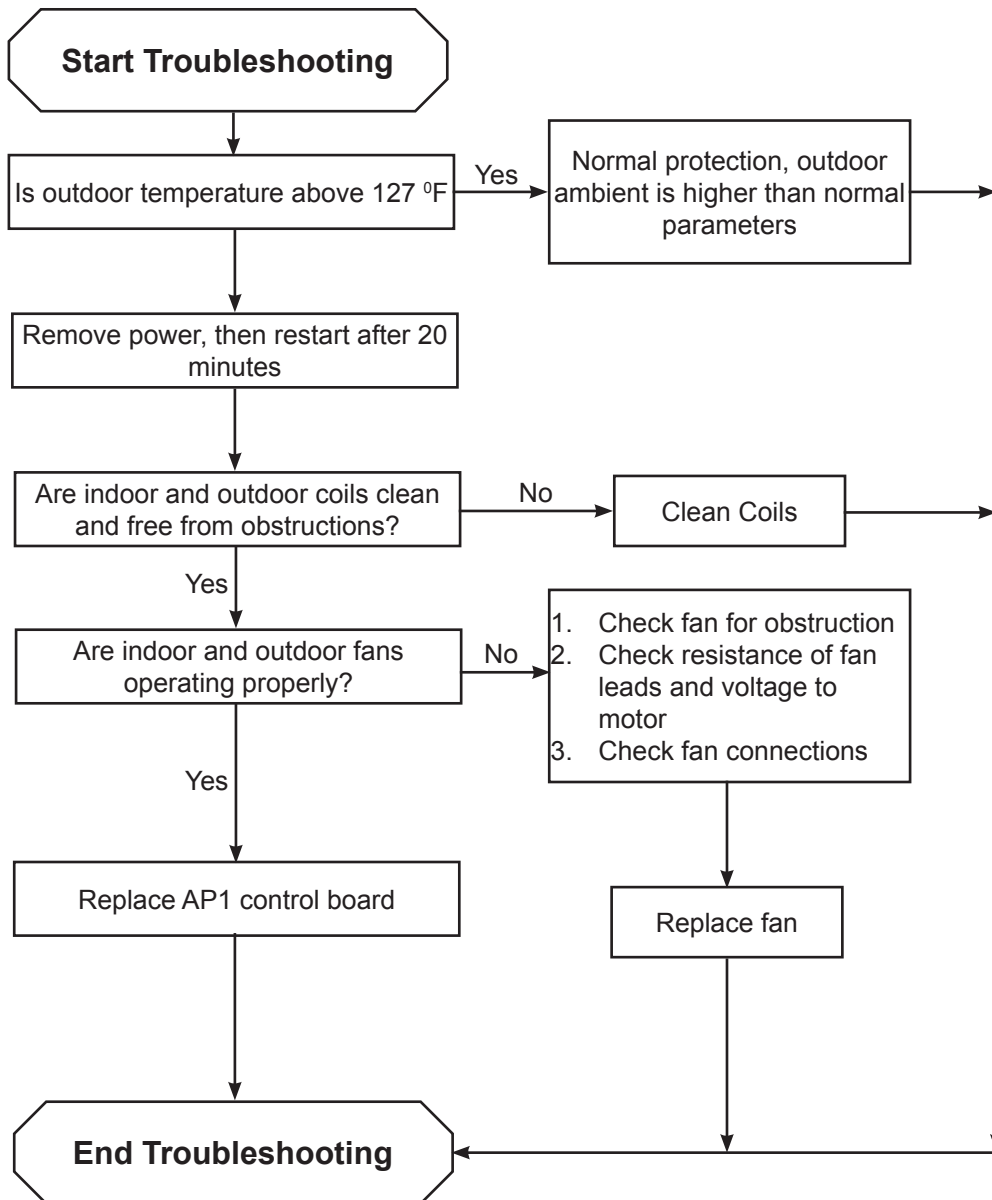

# Troubleshooting 18,000 & 24,000 Units

## Unit Will Not Start

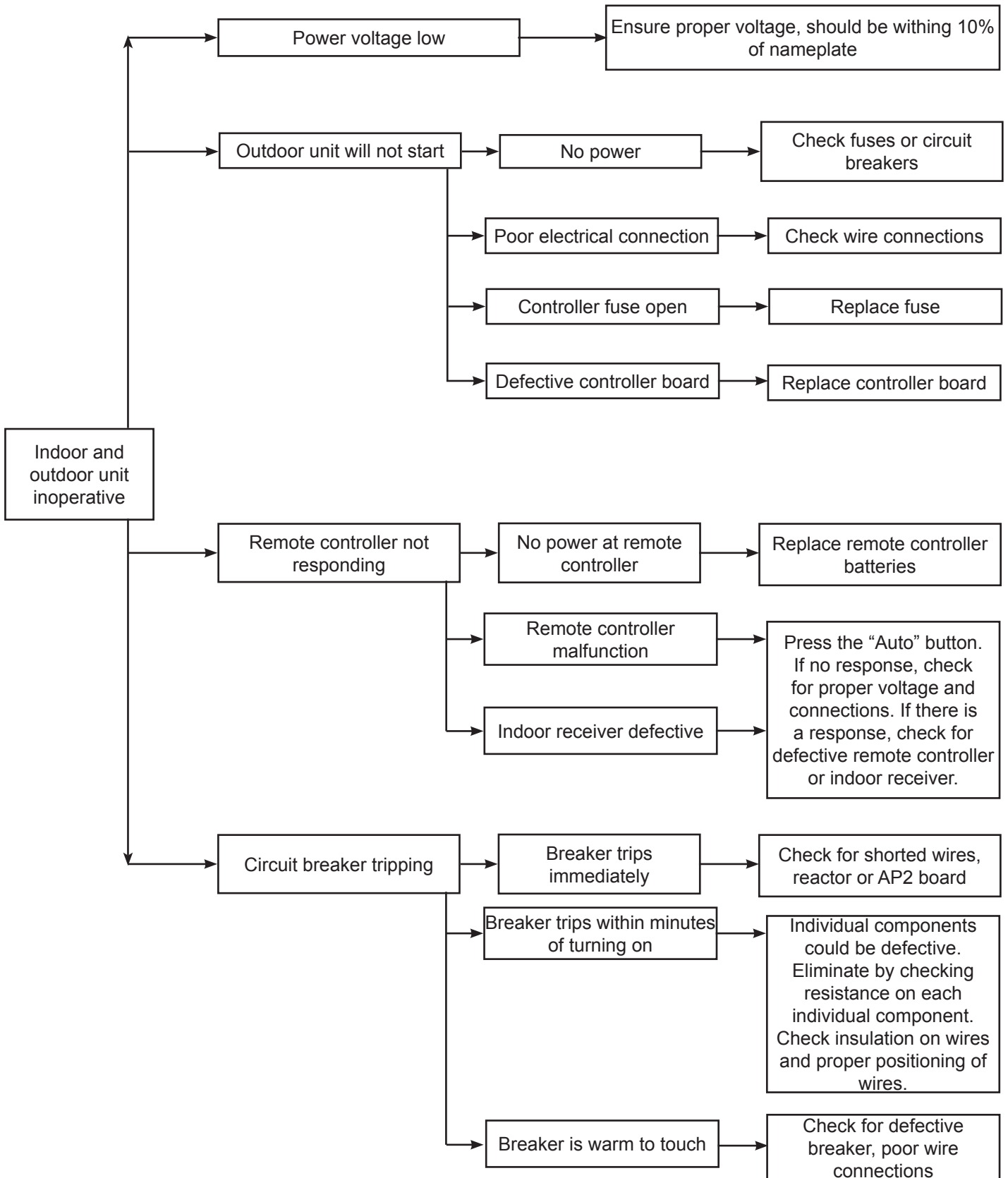



# Troubleshooting 18,000 & 24,000 Units

## Startup Failure

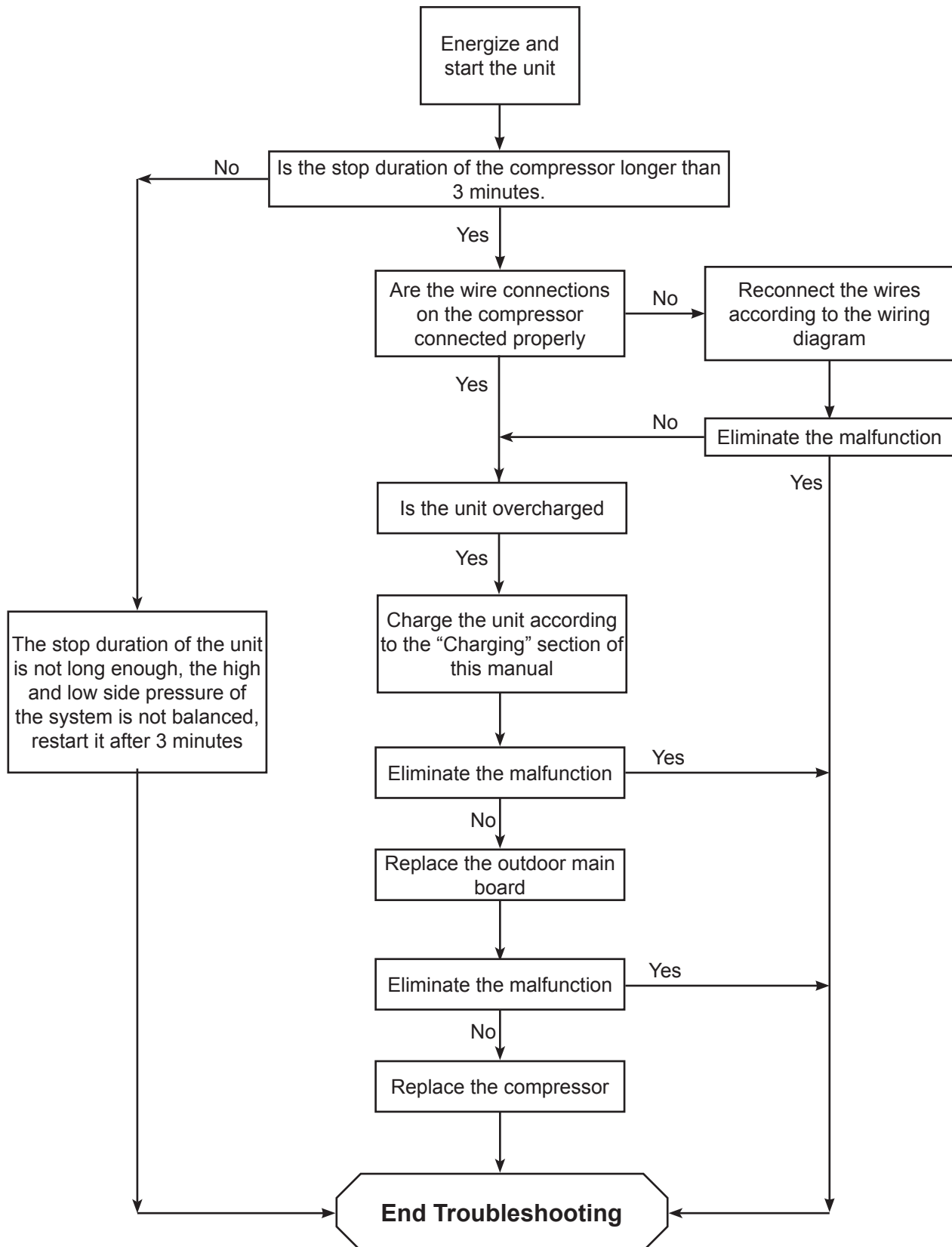

# Troubleshooting 18,000 & 24,000 Units

## Compressor Overload, Discharge Protection Malfunction

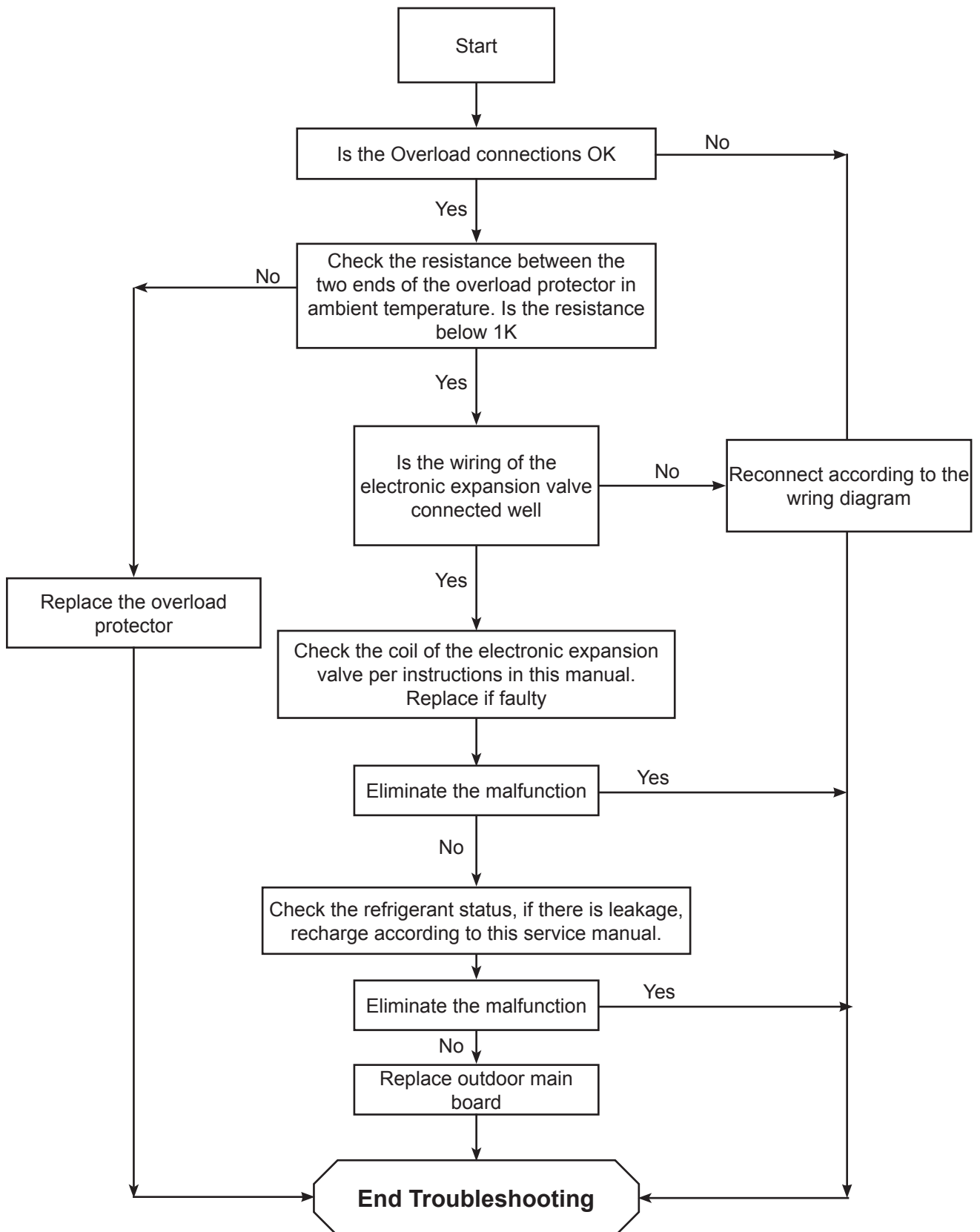

# Troubleshooting 18,000 & 24,000 Units

## PFC Malfunction (correction for power factor)

HC



### PFC (Power Factor Correction) Protection

#### Status:

During cooling & dehumidifying, indoor unit operates while other functions stop; During heating operation, complete unit stops

1. Check for damage to the reactor and PFC capacitor of the outdoor unit
2. Refer to troubleshooting procedure below

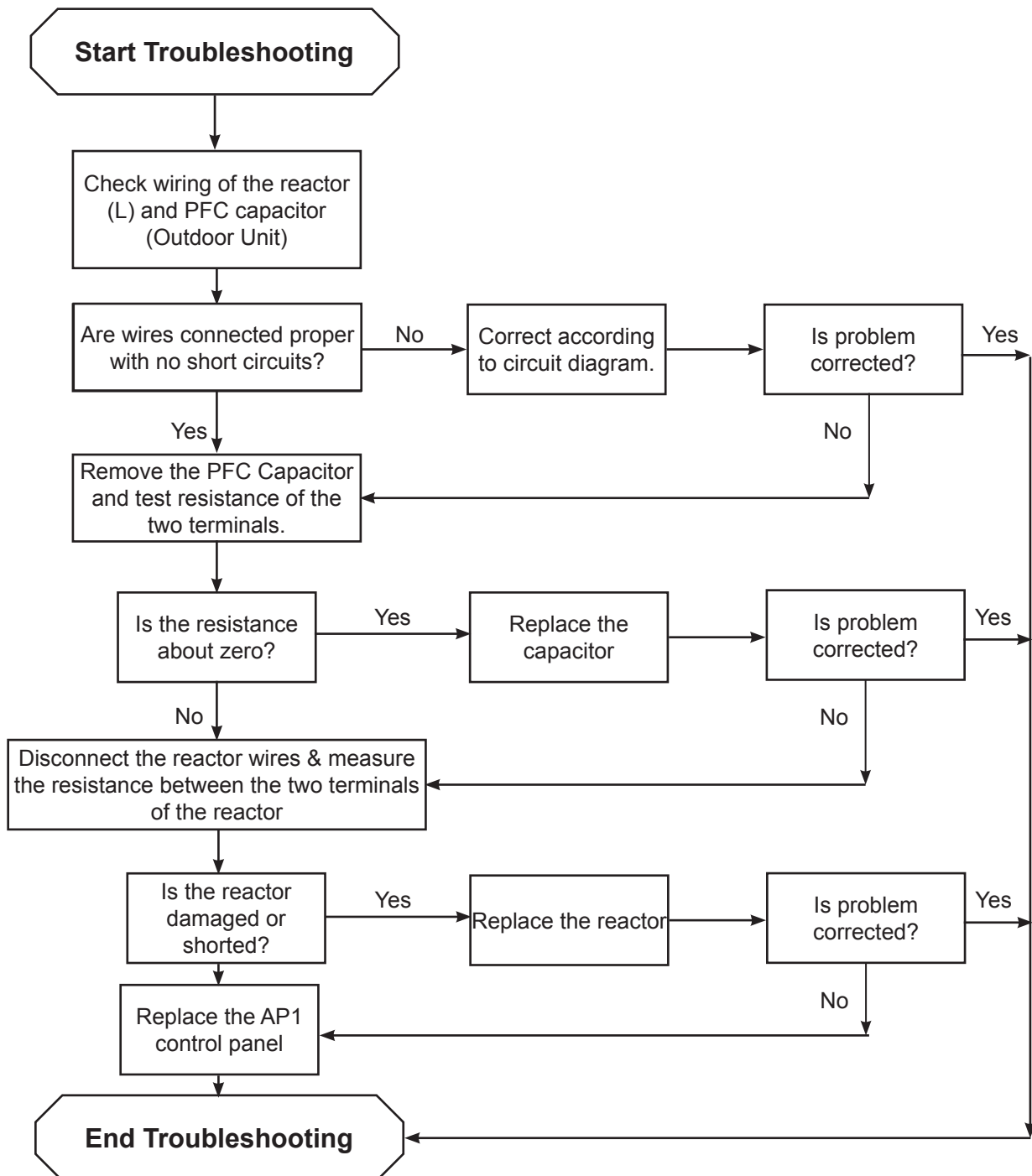

# Troubleshooting 18,000 & 24,000 Units

## Communication Malfunction of Indoor Unit, continued next page for Outdoor Unit

E6



### Communication Failure

#### **Status:**

Cooling operation, compressor stops while indoor fans runs. Heating operation, complete unit stops

1. Improper voltages
2. Mis-matched indoor and outdoor units
3. Improper wiring between indoor and outdoor units

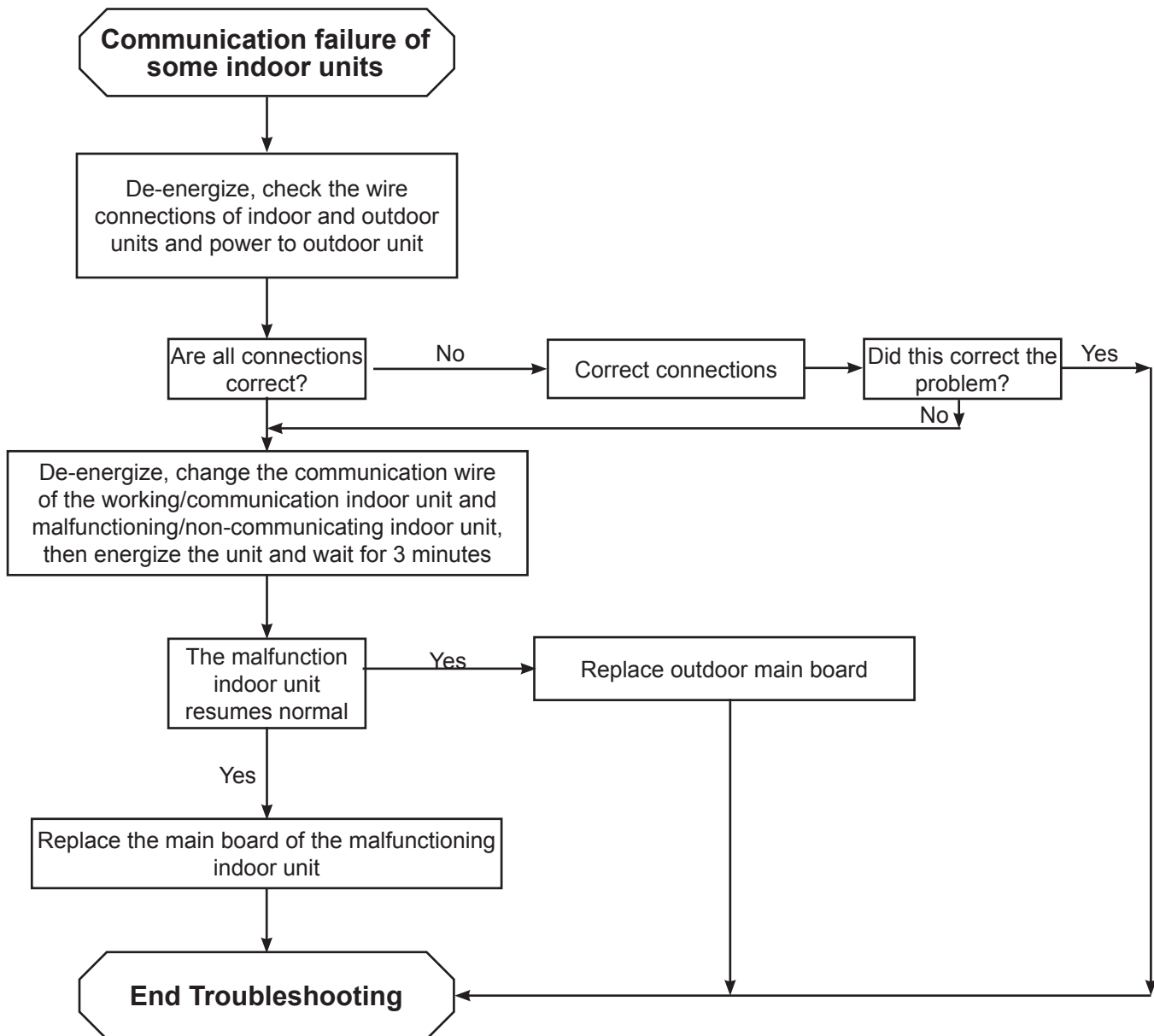

# Troubleshooting 18,000 & 24,000 Units

## Communication Malfunction of Outdoor Unit E6 Error Code continued

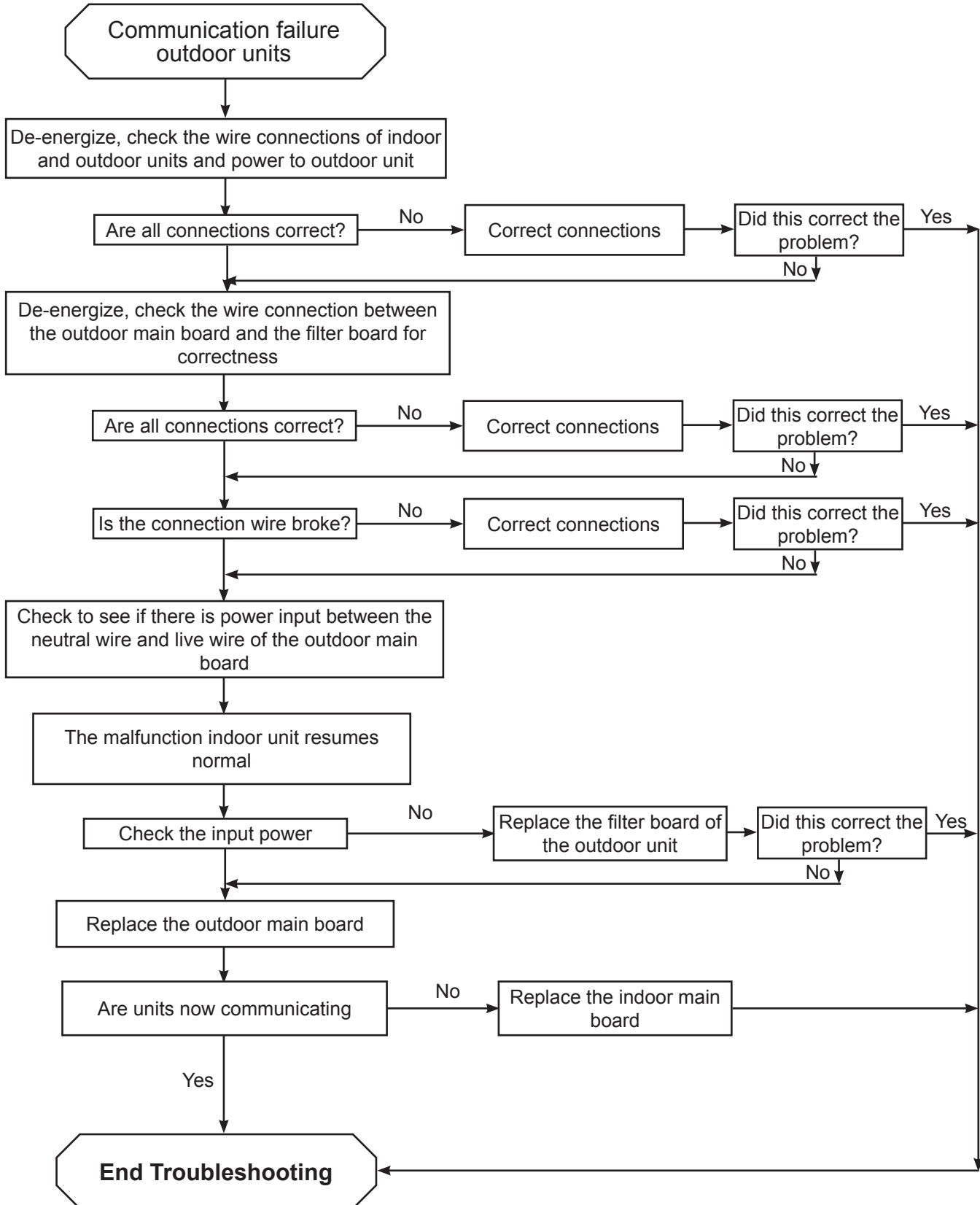

# General Troubleshooting

## Miscellaneous Malfunctions

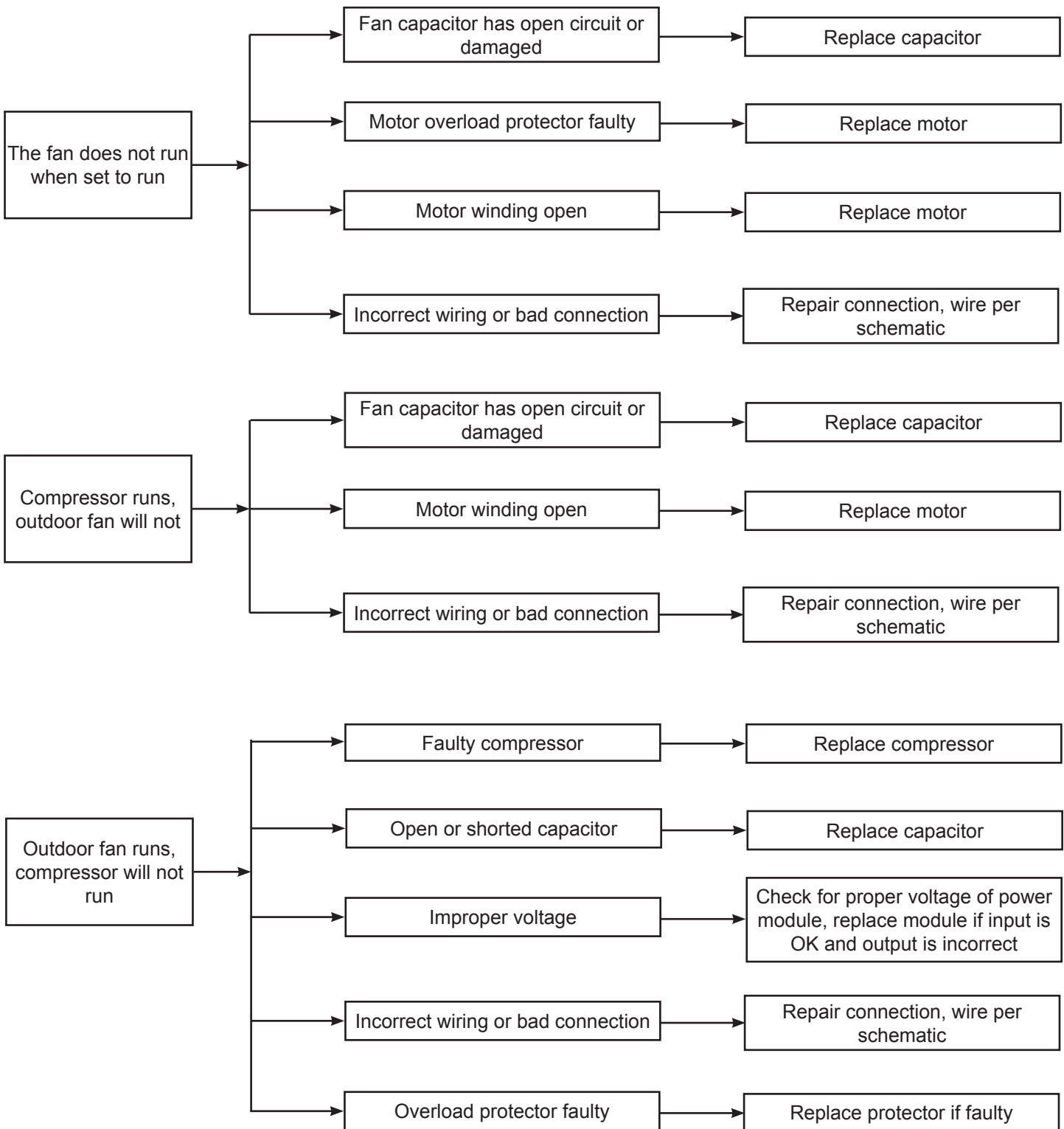

# General Troubleshooting

## Miscellaneous Malfunctions, cont.

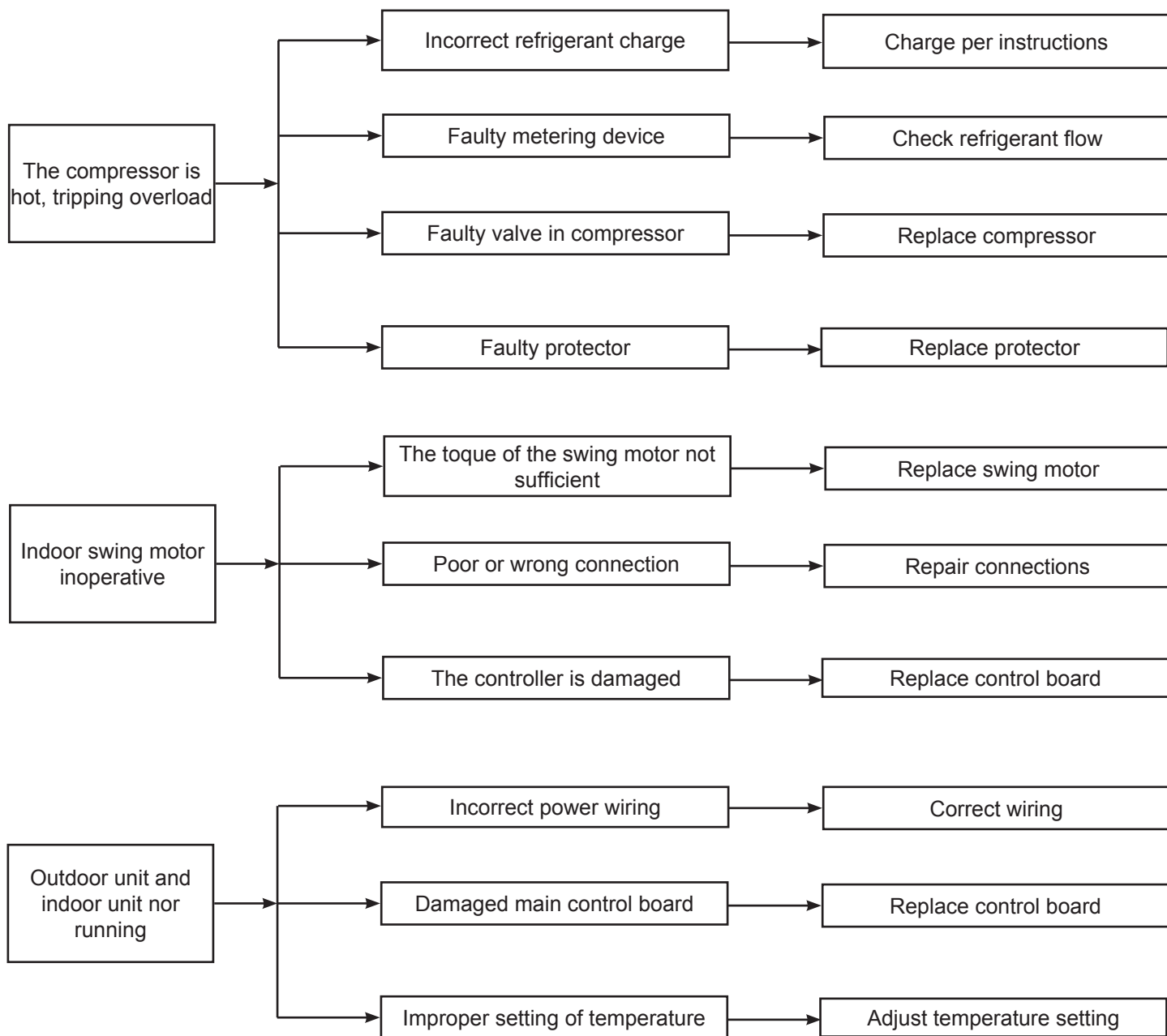

# General Troubleshooting

## Miscellaneous Malfunctions, cont.

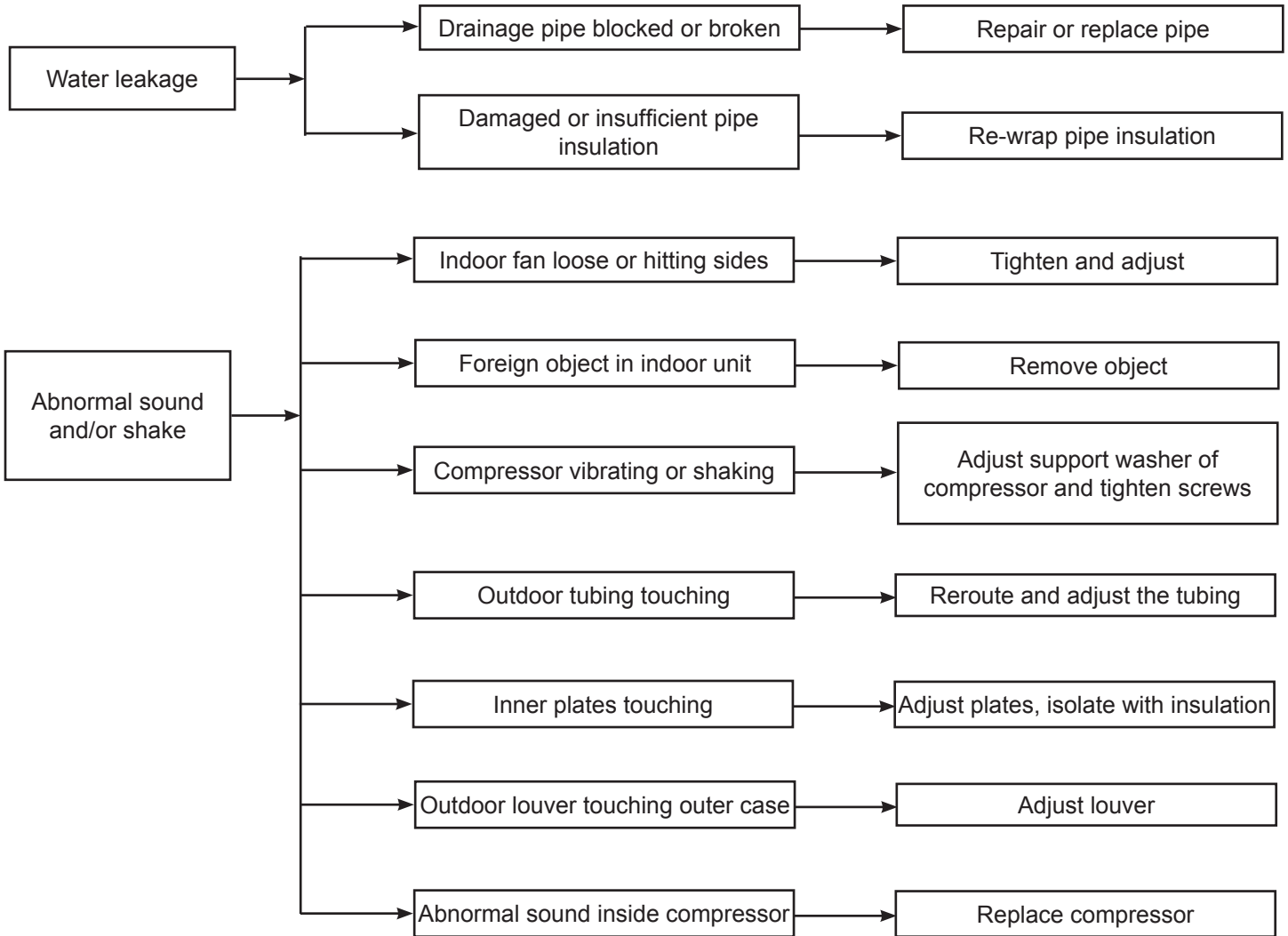



# General Troubleshooting

## Compressor Running Hot

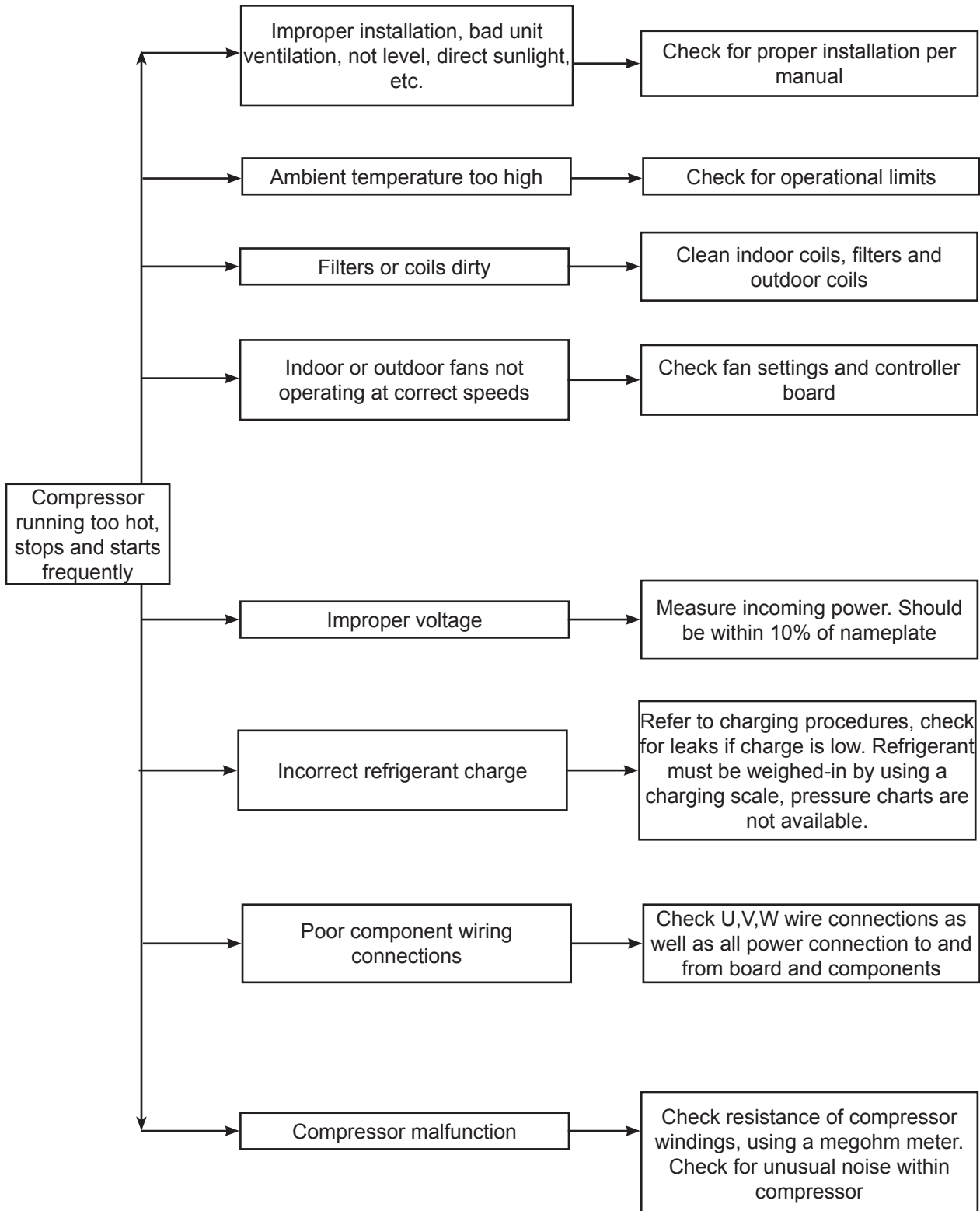

## Disassembly of RIO Indoor Unit

12,000 btuh Other models may vary slightly

*Warning - Wait 10 minutes after power is disconnected before starting disassembly.*

Hold On/Off button for 5 seconds to force a cooling operation for approximately 15 minutes.

### 1. Remove air filters

**Step 1.** Lift cover upward to lock open

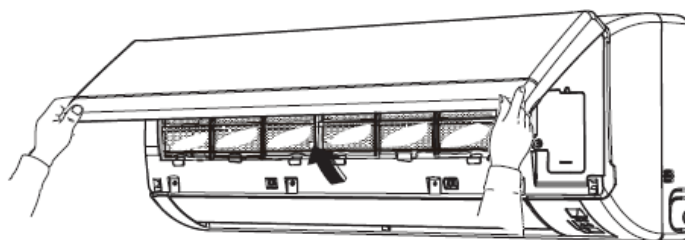

### 2. Remove filter

**Step 1.** Lift center of air filter outward

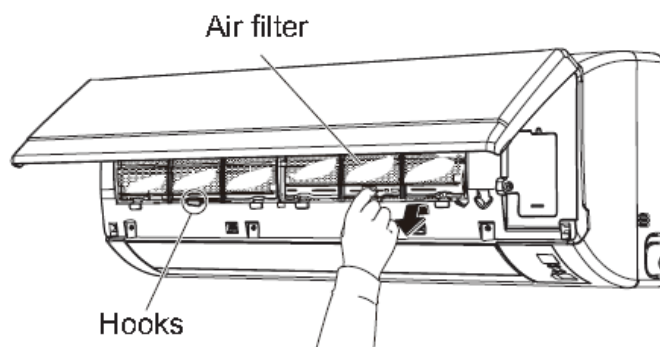

**Step 2.** Remove air filter by pulling forward

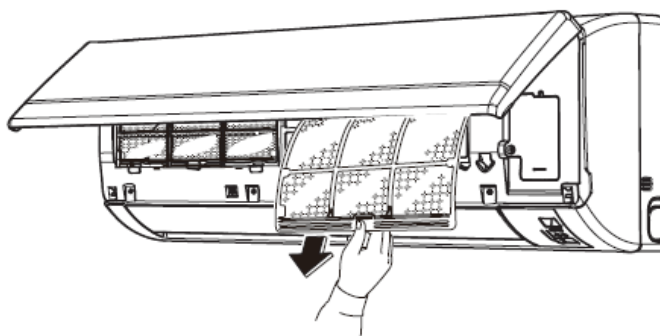

Left and right filters are interchangeable.

To reinstall, insert air filter along the guide.

## Disassembly of RIO Indoor Unit

12,000 btuh Other models may vary slightly

*Warning - Wait 10 minutes after power is disconnected before starting disassembly.*

### 3. Open front panel

**Step 1.** Slide axial bushing and remove bushing. Bend the horizontal louver slightly and remove.

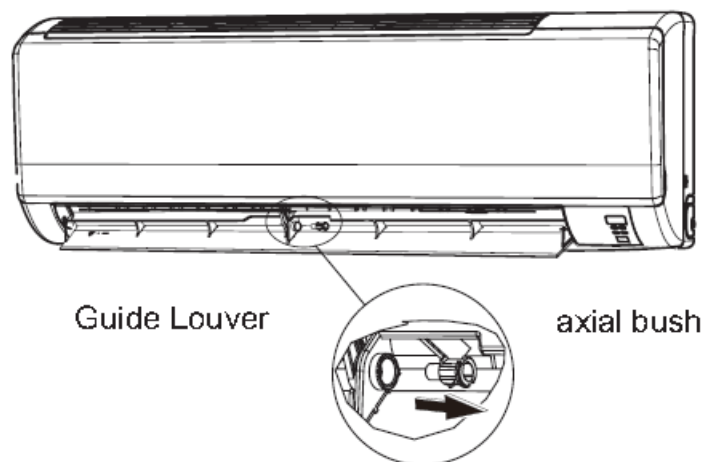

**Step 2.** Lift front panel upward until it locks into place. Slightly press left hinge inward to release from socket.

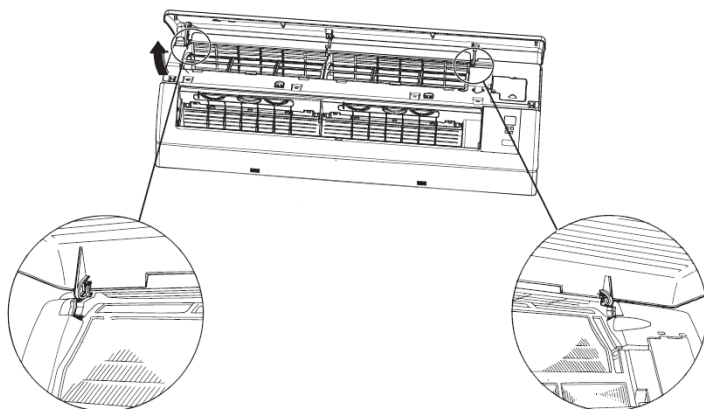

**Step 3.** Very carefully lift and slide cover to the left and remove.

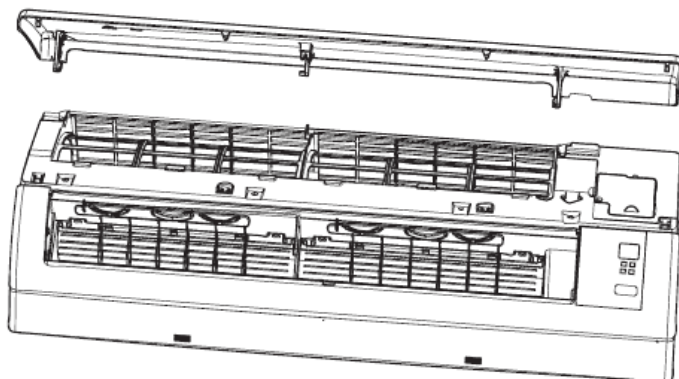

**Disassembly of RIO Indoor Unit**  
**12,000 btuh Other models may vary slightly**  
*Warning - Wait 10 minutes after power is disconnected before starting disassembly.*

Hold On/Off button for 5 seconds to force a cooling operation for approximately 15 minutes.

**4. Remove service cover**

**Step 1.** Remove screw holding service cover in place, then remove cover.

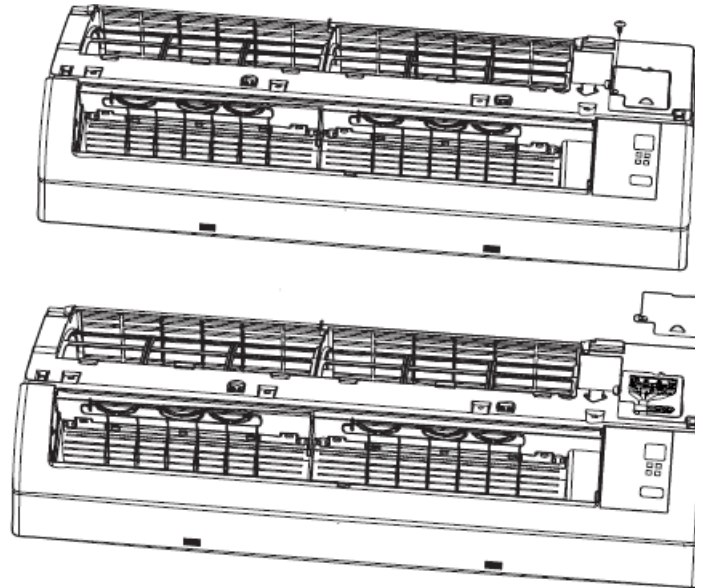

**5. Remove front grille assembly**

**Step 1.** Remove 5 screws as shown in the figure at right. Note: Some models may only have 3 screws.

**Step 2.** Disengage the 3 hooks on the upper portion

**Step 3.** The front grille can now be separated from the main portion.

**Note:** Disengage the hooks by pressing with a screw driver

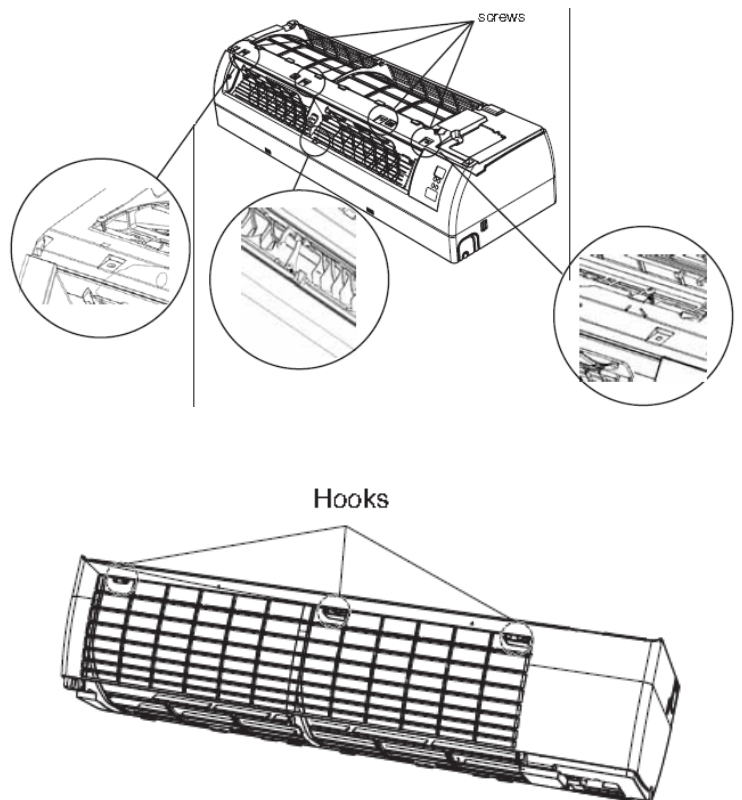

## Disassembly of RIO Indoor Unit

12,000 btuh Other models may vary slightly

*Warning - Wait 10 minutes after power is disconnected before starting disassembly.*

### 6. Open electrical box

**Step 1.** Disconnect the cable clamp

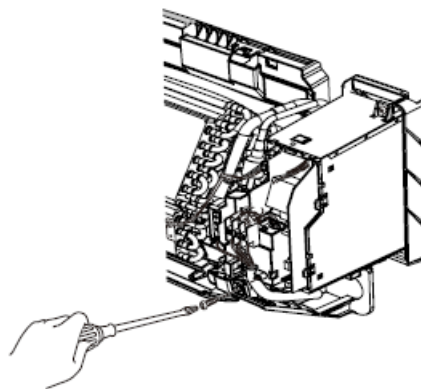

**Step 2.** Remove the temperature sensor. Disconnect the connection wires. Remove the screw from the evaporator. Remove wires from terminals.

**Note:** Take care not to lose the thermistor clip. Pay attention to the mounting of the thermistor, replace in exact manner.

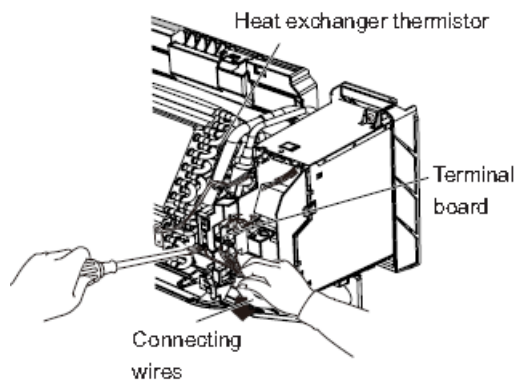

**Step 3.** Remove the screw holding the electrical box to the chassis, remove electrical box.

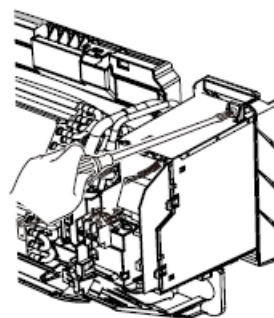

## Disassembly of RIO Indoor Unit

12,000 btuh Other models may vary slightly

*Warning - Wait 10 minutes after power is disconnected before starting disassembly.*

Hold On/Off button for 5 seconds to force a cooling operation for approximately 15 minutes.

### 7. Remove tubing assembly

**Step 1.** Remove tubing clamp

**Step 2.** Adjust the tubing slightly

**Step 3.** Loosen the screws, in the right and the left, which hold the evaporator assembly. Remove the evaporator assembly.

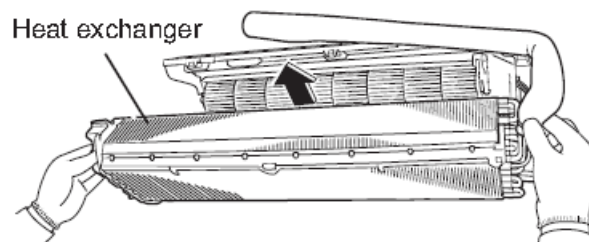
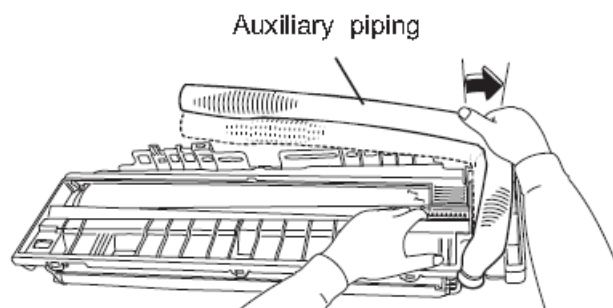
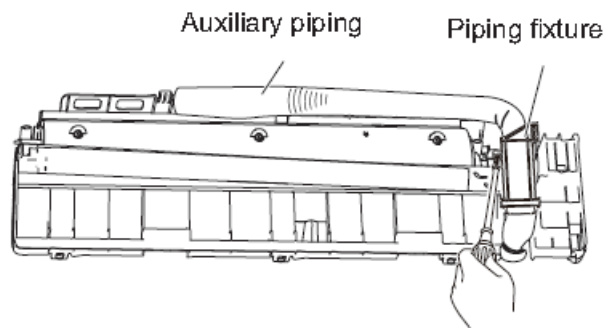

## Disassembly of RIO Indoor Unit

12,000 btuh Other models may vary slightly

*Warning - Wait 10 minutes after power is disconnected before starting disassembly.*

### 8. Remove the pressure plate of the motor

**Step 1.** Remove the screws of motor plate, then remove the motor plate.

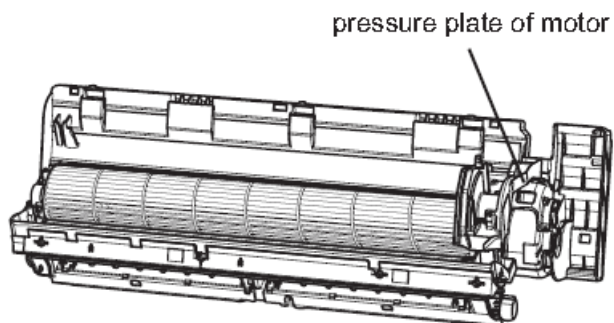

### 9. Remove shaft cushion rubber base

**Step 1.** Remove motor, blade and shaft cushion rubber base.

**Step 2.** Remove screws on cross flow blade and then remove the motor.

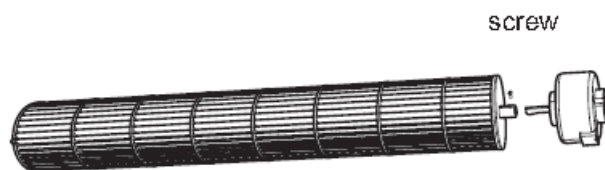
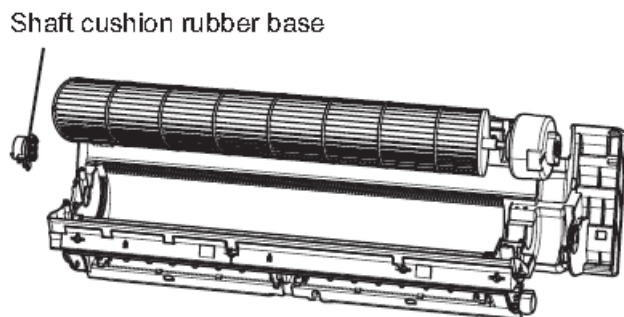

## Disassembly of Outdoor Unit

9,000 & 12,000 btuh

**Warning - Wait 10 minutes after power is disconnected before starting disassembly.**

**Warning** Be sure to wait a minimum of 10 minutes after turning off all power supplies before disassembly

### 1. Remove tubing assembly

#### 1. Remove handle

Remove screws holding handle, pull down handle and remove.

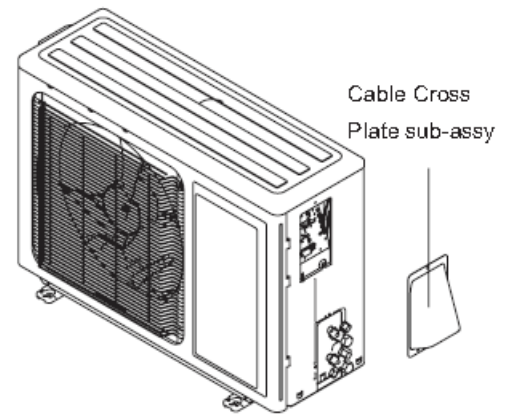
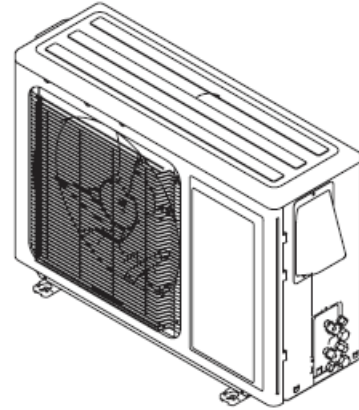

### 2. Remove top panel

#### 1. Remove top panel

Remove the screws (front, right, left). then remove panel.

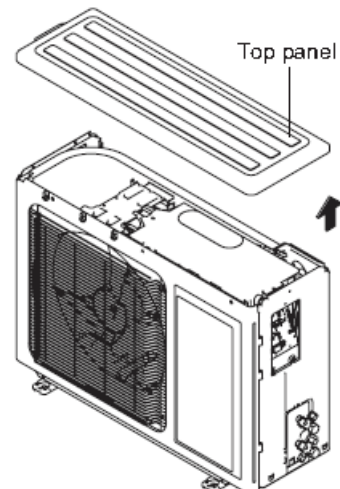



## Disassembly of Outdoor Unit

9,000 & 12,000 btuh

*Warning - Wait 10 minutes after power is disconnected before starting disassembly.*

### 3. Remove grille and front panel

1. Loosen screws and remove the discharge grille

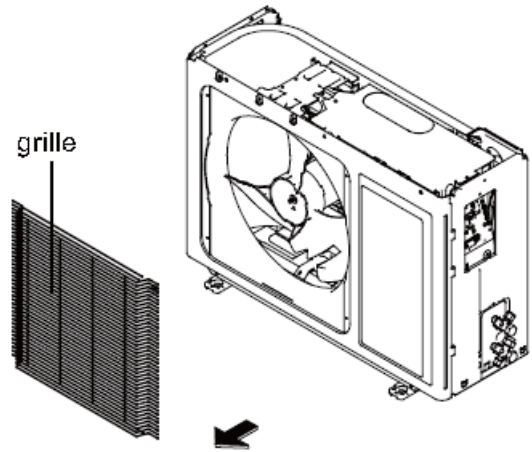

2. Loosen the 5 screws holding the front panel.

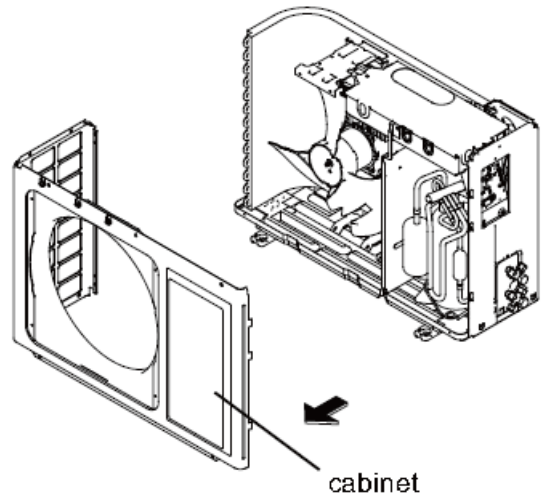

### 4. Remove right side panel

1. Remove the 5 screws from the edge between right-side board, condenser and valve. **Lift to remove the right side panel**

2. Loosen the 5 screws holding the front panel.

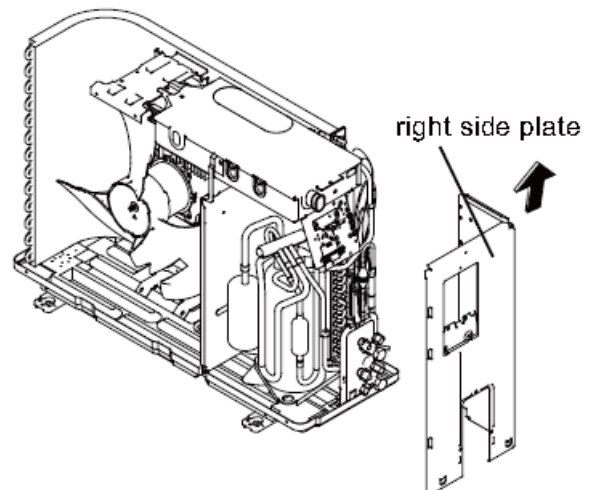

## Disassembly of Outdoor Unit

9,000 & 12,000 btuh

**Warning - Wait 10 minutes after power is disconnected before starting disassembly.**

### 5. Remove fan motor and axial blade

1. Remove the screws of the fan and then remove the axial blade along with motor assembly.

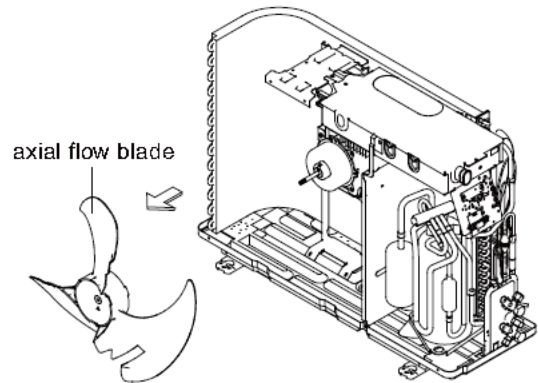

2. Remove the 4 tapping screws holding the motor to the bracket. Pull out wires and remove the motor. Remove the two tapping screws holding the motor support, then lift out support.

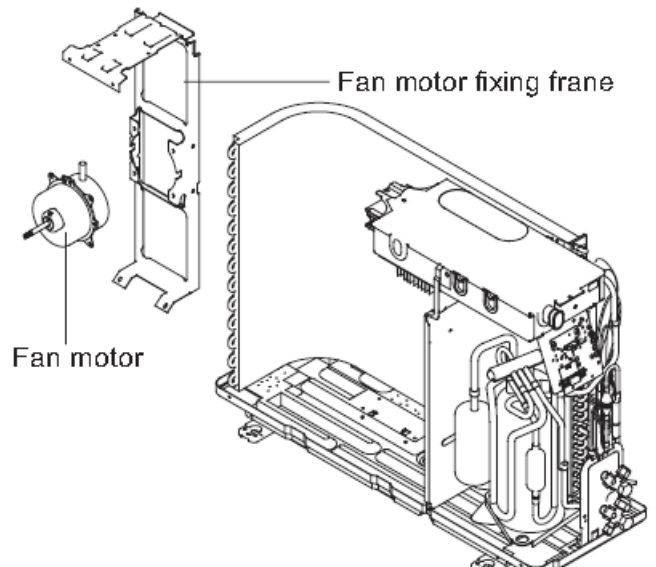

### 6. Remove electric box

1. Loosen two screws

2. The partition plate has a hook on the lower side. Lift and pull the partition plate to remove.

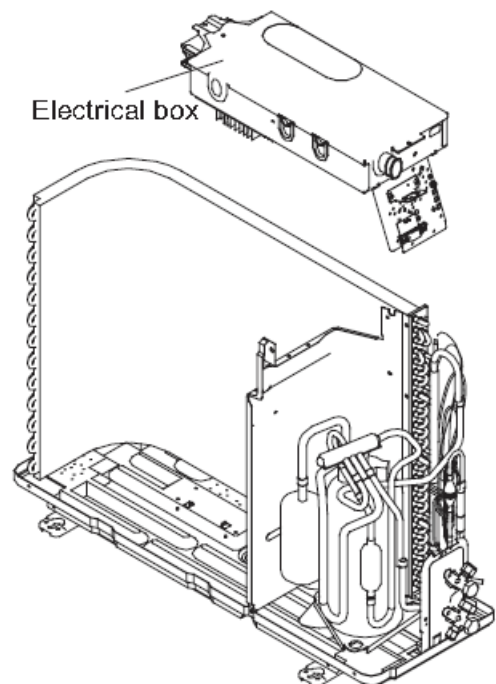

## Disassembly of Outdoor Unit

9,000 & 12,000 btuh

**Warning - Wait 10 minutes after power is disconnected before starting disassembly.**

### 7. Remove the partition plate

1. Loosen the two screws

2. The partition plate has a hook on the lower side.  
Lift and pull the partition plate to remove.

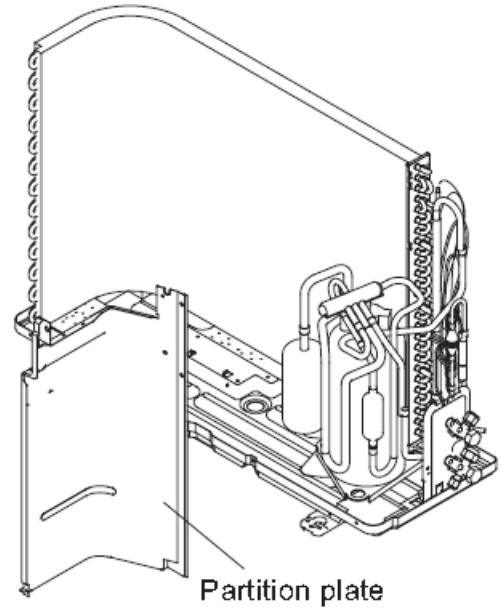

## Disassembly of Outdoor Unit

9,000 & 12,000 btuh

**Warning - Wait 10 minutes after power is disconnected before starting disassembly.**

### 8. Remove compressor

1. Remove 4-way valve and tubing by un-soldering. Properly remove all refrigerant.

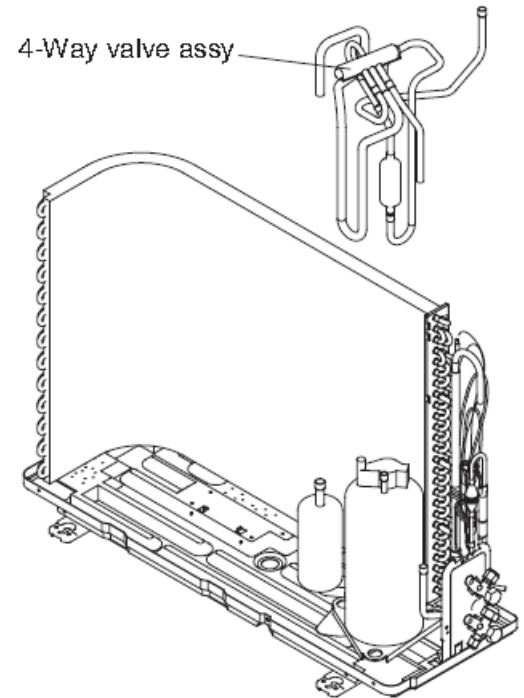

2. Remove the 3 footing screws holding compressor, then remove the compressor.

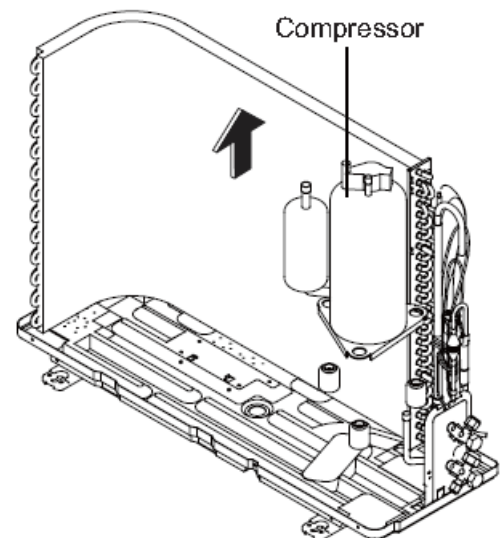

## Disassembly of Outdoor Unit

9,000 & 12,000 btuh

**Warning - Wait 10 minutes after power is disconnected before starting disassembly.**

### 8. Remove compressor, cont.

3. Remove screws holding gas valve assembly, unsolder the joint between the gas valve and condensor piping, then remove gas valve. Before applying heat to the tubing, protect the gas valve by wrapping in a wet cloth.

Remove screws holding liquid valve assembly, unsolder the joint between the liquid valve and Y-Type tubing, then remove liquid valve. Before applying heat to the tubing, protect the liquid valve by wrapping in a wet cloth.

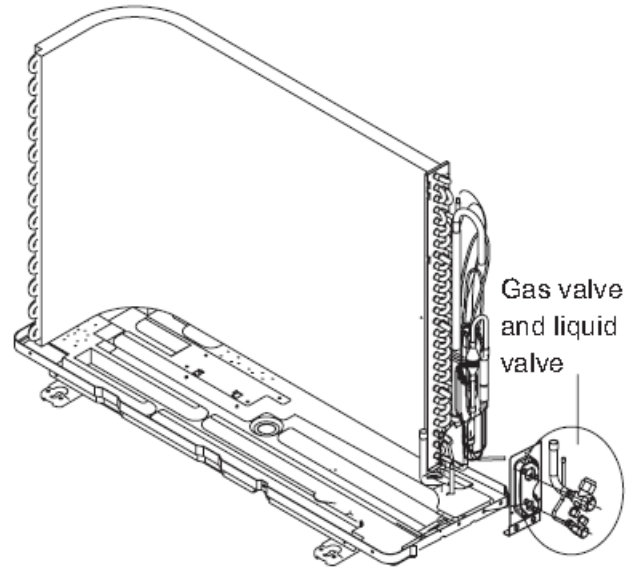

## Disassembly of Outdoor Unit

18,000 and 24,000 btuh

**Warning - Wait 10 minutes after power is disconnected before starting disassembly.**

**Warning** Be sure to wait a minimum of 10 minutes after turning off all power supplies before disassembly

### 1. Remove top cover plate, valve cover and handle

1. Before disassembly

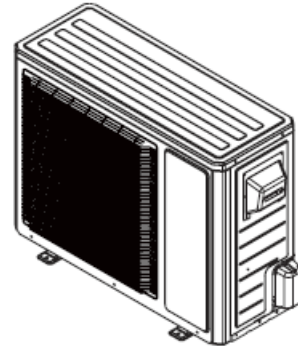

2. Remove screws holding the handle and valve cover, pull handle and valve cover upward to remove.

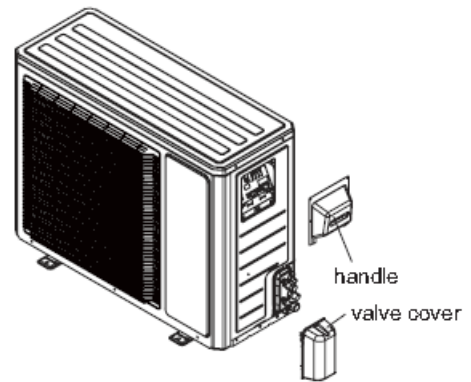

3. Remove screws holding the top cover, then pull upward to remove.

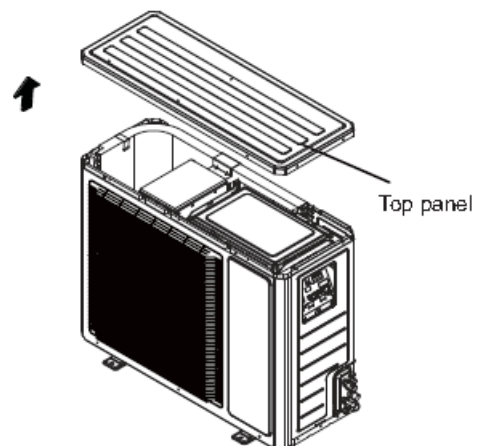

## Disassembly of Outdoor Unit

18,000 and 24,000 btuh

**Warning - Wait 10 minutes after power is disconnected before starting disassembly.**

### 2. Remove grille and front panel

1. Loosen screws and remove the discharge grille

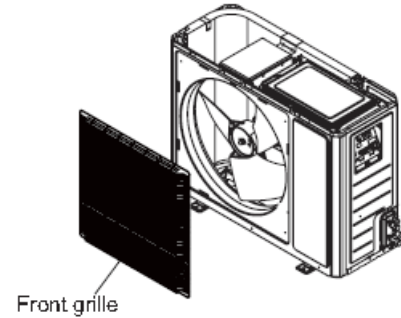

2. Loosen the screws holding the front panel, loosen the clasp on the right side, rotate to the left then remove the panel.

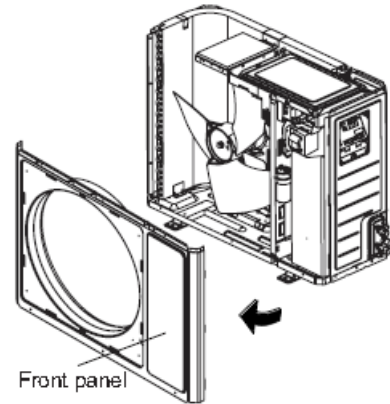

### 3. Remove right and left side panels

1. Remove the screws holding the right side panel to the valve support and electric box, then remove the panel.

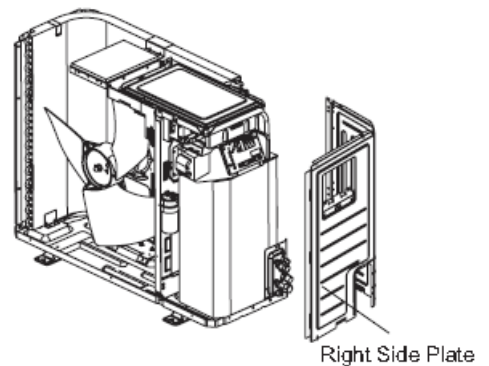

2. Loosen the screws holding the left side panel and remove panel.

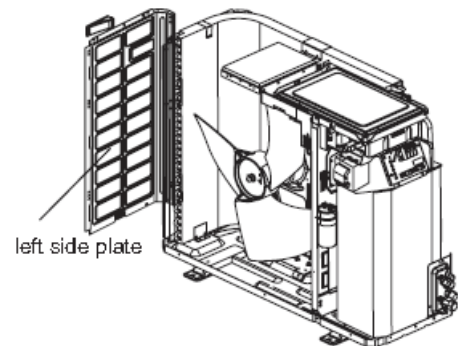

## Disassembly of Outdoor Unit

18,000 and 24,000 btuh

**Warning - Wait 10 minutes after power is disconnected before starting disassembly.**

### 4. Remove the axial flow fan

1. Remove the nuts holding the fan blade, then remove the blade.

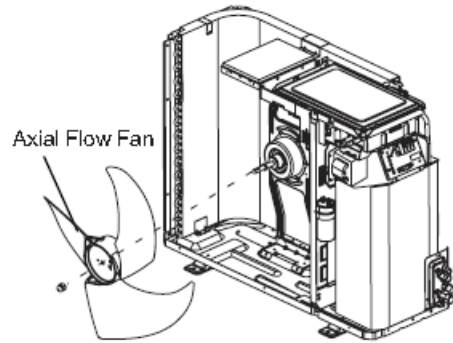

2. Remove the four screws holding the motor, disconnect the leading wire insert of the motor, then remove the motor. Remove the two screws holding the support then pull upward the support to remove.

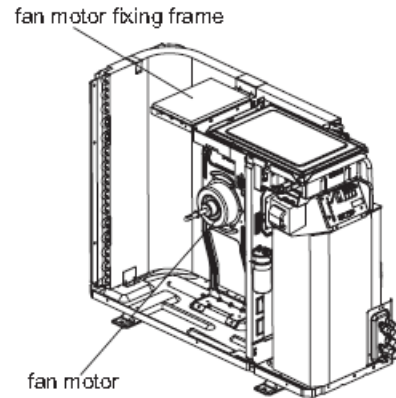

### 5. Remove the electric box

1. Remove the screws holding the electric box sub assembly, loosen the wire bundle, pull wires off of terminals, then remove the electric box.

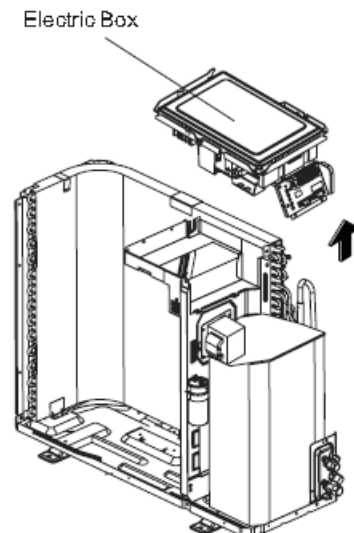



## Disassembly of Outdoor Unit

18,000 and 24,000 btuh

**Warning - Wait 10 minutes after power is disconnected before starting disassembly.**

### 6. Remove fireproof electric box and sound proof sponge

1. Remove the screws holding fireproof electric box, then remove box.
2. Carefully remove sponge. Avoid tearing sponge when removing.

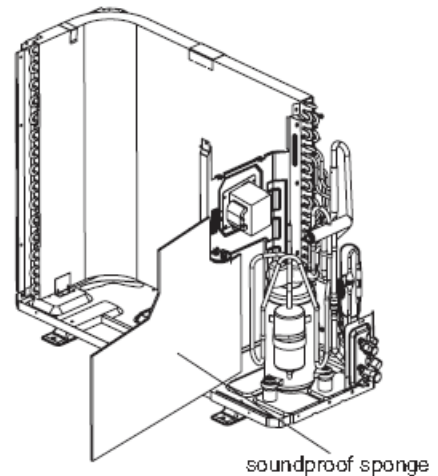
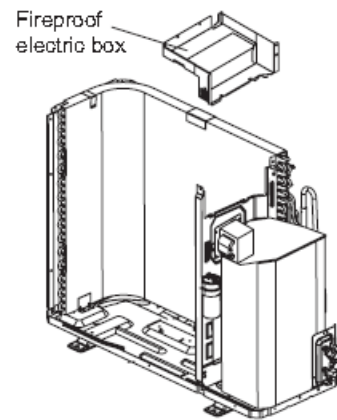

### 7. Remove isolation sheet

1. Remove the screws holding the isolation sheet, then carefully remove.

Note:

Notice how sheet is positioned for aid in replacing.

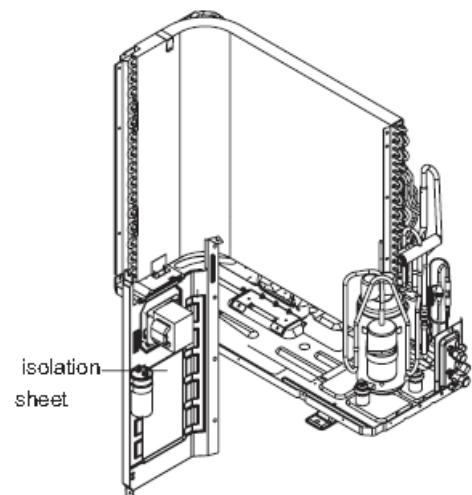

## Disassembly of Outdoor Unit

18,000 and 24,000 btuh

**Warning - Wait 10 minutes after power is disconnected before starting disassembly.**

### 8. Remove the 4 way valve assembly

1. Remove the screws holding the 4-way valve coil.

Properly remove refrigerant, protect valve from heat damage and remove valve.

2. Unsolder the tubing connecting the compressor and condenser assembly, then remove the 4-way valve.

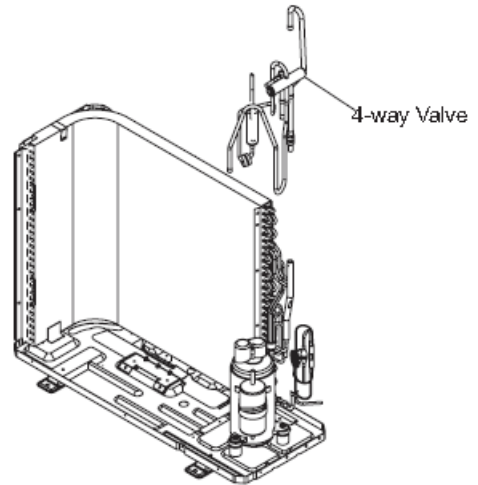

### 9. Remove compressor

1. Remove the three foot nuts on compressor, then carefully remove the compressor.

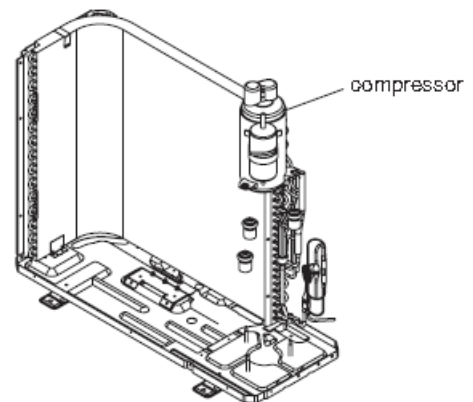

## Disassembly of Outdoor Unit

18,000 and 24,000 btuh

*Warning - Wait 10 minutes after power is disconnected before starting disassembly.*

### 10.. Remove condenser sub-assembly

1. Remove the screws connecting the support (condenser) and condenser assembly, then remove the support.

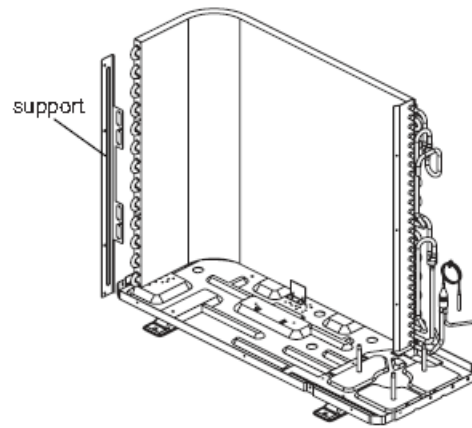

2. Carefully remove the chassis sub assembly and condenser sub assembly.

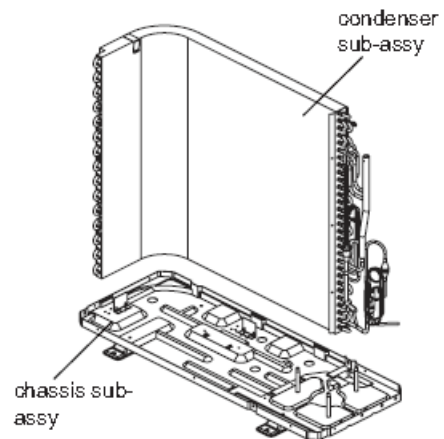

**Appendix 1: Resistance Table of Ambient Temperature Sensor for Indoor and Outdoor Units (15K)**

Temp (°C)	Temp (°F)	Resistance (kΩ)		Temp (°C)	Temp (°F)	Resistance (kΩ)		Temp (°C)	Temp (°F)	Resistance (kΩ)
-19	-2.2	138.1		33	91.4	10.63		85	185.0	1.594
-18	-0.4	128.6		34	93.2	10.2		86	186.8	1.544
-17	1.4	121.6		35	95.0	9.779		87	188.6	1.497
-16	3.2	115		36	96.8	9.382		88	190.4	1.451
-15	5.0	108.7		37	98.6	9.003		89	192.2	1.408
-14	6.8	102.9		38	100.4	8.642		90	194.0	1.363
-13	8.6	97.4		39	102.2	8.297		91	195.8	1.322
-12	10.4	92.22		40	104.0	7.967		92	197.6	1.282
-11	12.2	87.35		41	105.8	7.653		93	199.4	1.244
-10	14.0	82.75		42	107.6	7.352		94	201.2	1.207
-9	15.8	78.43		43	109.4	7.065		95	203.0	1.171
-8	17.6	74.35		44	111.2	6.791		96	204.8	1.136
-7	19.4	70.5		45	113.0	6.529		97	206.6	1.103
-6	21.2	66.88		46	114.8	6.278		98	208.4	1.071
-5	23.0	63.46		47	116.6	6.038		99	210.2	1.039
-4	24.8	60.23		48	118.4	5.809		100	212.0	1.009
-3	26.6	57.18		49	120.2	5.589		101	213.8	0.98
-2	28.4	54.31		50	122.0	5.379		102	215.6	0.952
-1	30.2	51.59		51	123.8	5.197		103	217.4	0.925
0	32.0	49.02		52	125.6	4.986		104	219.2	0.898
1	33.8	46.6		53	127.4	4.802		105	221.0	0.873
2	35.6	44.31		54	129.2	4.625		106	222.8	0.848
3	37.4	42.14		55	131.0	4.456		107	224.6	0.825
4	39.2	40.09		56	132.8	4.294		108	226.4	0.802
5	41.0	38.15		57	134.6	4.139		109	228.2	0.779
6	42.8	36.32		58	136.4	3.99		110	230.0	0.758
7	44.6	34.58		59	138.2	3.848		111	231.8	0.737
8	46.4	32.94		60	140.0	3.711		112	233.6	0.717
9	48.2	31.38		61	141.8	3.579		113	235.4	0.697

**Appendix 1: Resistance Table of Ambient Temperature Sensor for Indoor and Outdoor Units (15K)**

Temp (°C)	Temp (°F)	Resistance (kΩ)		Temp (°C)	Temp (°F)	Resistance (kΩ)		Temp (°C)	Temp (°F)	Resistance (kΩ)
10	50.0	29.9		62	143.6	3.454		114	237.2	0.678
11	51.8	28.51		63	145.4	3.333		115	239.0	0.66
12	53.6	27.18		64	147.2	3.217		116	240.8	0.642
13	55.4	25.92		65	149.0	3.105		117	242.6	0.625
14	57.2	24.73		66	150.8	2.998		118	244.4	0.608
15	59.0	23.6		67	152.6	2.896		119	246.2	0.592
16	60.8	22.53		68	154.4	2.797		120	248.0	0.577
17	62.6	21.51		69	156.2	2.702		121	249.8	0.561
18	64.4	20.54		70	158.0	2.611		122	251.6	0.547
19	66.2	19.63		71	159.8	2.523		123	253.4	0.532
20	68.0	18.75		72	161.6	2.439		124	255.2	0.519
21	69.8	17.93		73	163.4	2.358		125	257.0	0.505
22	71.6	17.14		74	165.2	2.28		126	258.8	0.492
23	73.4	16.39		75	167.0	2.206		127	260.6	0.48
24	75.2	15.68		76	168.8	2.133		128	262.4	0.467
25	77.0	15		77	170.6	2.064		129	264.2	0.456
26	78.8	14.36		78	172.4	1.997		130	266.0	0.44
27	80.6	13.74		79	174.2	1.933		131	267.8	0.433
28	82.4	13.16		80	176.0	1.871		132	269.6	0.422
29	84.2	12.6		81	177.8	1.811		133	271.4	0.412
30	86.0	12.07		82	179.6	1.754		134	273.2	0.401
31	87.8	11.57		83	181.4	1.699		135	275.0	0.391

**Appendix 2: Resistance Table of Outdoor and Indoor Tube Temperature Sensors (20K)**

Temp (°C)	Temp (°F)	Resistance (kΩ)		Temp (°C)	Temp (°F)	Resistance (kΩ)		Temp (°C)	Temp (°F)	Resistance (kΩ)
-19	-2.2	181.4		33	91.4	14.18		85	185.0	2.125
-18	-0.4	171.4		34	93.2	13.59		86	186.8	2.059
-17	1.4	162.1		35	95.0	13.04		87	188.6	1.996
-16	3.2	153.3		36	96.8	12.51		88	190.4	1.934
-15	5.0	145		37	98.6	12		89	192.2	1.875
-14	6.8	137.2		38	100.4	11.52		90	194.0	1.818
-13	8.6	129.9		39	102.2	11.06		91	195.8	1.736
-12	10.4	123		40	104.0	10.62		92	197.6	1.71
-11	12.2	116.5		41	105.8	10.2		93	199.4	1.658
-10	14.0	110.3		42	107.6	9.803		94	201.2	1.609
-9	15.8	104.6		43	109.4	9.42		95	203.0	1.561
-8	17.6	99.13		44	111.2	9.054		96	204.8	1.515
-7	19.4	94		45	113.0	8.705		97	206.6	1.47
-6	21.2	89.17		46	114.8	8.37		98	208.4	1.427
-5	23.0	84.61		47	116.6	8.051		99	210.2	1.386
-4	24.8	80.31		48	118.4	7.745		100	212.0	1.346
-3	26.6	76.24		49	120.2	7.453		101	213.8	1.307
-2	28.4	72.41		50	122.0	7.173		102	215.6	1.269
-1	30.2	68.79		51	123.8	6.905		103	217.4	1.233
0	32.0	65.37		52	125.6	6.648		104	219.2	1.198
1	33.8	62.13		53	127.4	6.403		105	221.0	1.164
2	35.6	59.08		54	129.2	6.167		106	222.8	1.131
3	37.4	56.19		55	131.0	5.942		107	224.6	1.099
4	39.2	53.46		56	132.8	5.726		108	226.4	1.069
5	41.0	50.87		57	134.6	5.519		109	228.2	1.039
6	42.8	48.42		58	136.4	5.32		110	230.0	1.01
7	44.6	46.11		59	138.2	5.13		111	231.8	0.983
8	46.4	43.92		60	140.0	4.948		112	233.6	0.956
9	48.2	41.84		61	141.8	4.773		113	235.4	0.93

**Appendix 2: Resistance Table of Outdoor and Indoor Tube Temperature Sensors (20K)**

Temp (°C)	Temp (°F)	Resistance (kΩ)		Temp (°C)	Temp (°F)	Resistance (kΩ)		Temp (°C)	Temp (°F)	Resistance (kΩ)
10	50.0	39.87		62	143.6	4.605		114	237.2	0.904
11	51.8	38.01		63	145.4	4.443		115	239.0	0.88
12	53.6	36.24		64	147.2	4.289		116	240.8	0.856
13	55.4	34.57		65	149.0	4.14		117	242.6	0.833
14	57.2	32.98		66	150.8	3.998		118	244.4	0.811
15	59.0	31.47		67	152.6	3.861		119	246.2	0.77
16	60.8	30.04		68	154.4	3.729		120	248.0	0.769
17	62.6	28.68		69	156.2	3.603		121	249.8	0.746
18	64.4	27.39		70	158.0	3.481		122	251.6	0.729
19	66.2	26.17		71	159.8	3.364		123	253.4	0.71
20	68.0	25.01		72	161.6	3.252		124	255.2	0.692
21	69.8	23.9		73	163.4	3.144		125	257.0	0.674
22	71.6	22.85		74	165.2	3.04		126	258.8	0.658
23	73.4	21.85		75	167.0	2.94		127	260.6	0.64
24	75.2	20.9		76	168.8	2.844		128	262.4	0.623
25	77.0	20		77	170.6	2.752		129	264.2	0.607
26	78.8	19.14		78	172.4	2.663		130	266.0	0.592
27	80.6	18.13		79	174.2	2.577		131	267.8	0.577
28	82.4	17.55		80	176.0	2.495		132	269.6	0.563
29	84.2	16.8		81	177.8	2.415		133	271.4	0.549
30	86.0	16.1		82	179.6	2.339		134	273.2	0.535
31	87.8	15.43		83	181.4	2.265		135	275.0	0.521
32	89.6	14.79		84	183.2	2.194		136	276.8	0.509

### Appendix 3: Resistance Table of Outdoor Discharge Temperature Sensor (50K)

Temp (°C)	Temp (°F)	Resistance (kΩ)	Temp (°C)	Temp (°F)	Resistance (kΩ)	Temp (°C)	Temp (°F)	Resistance (kΩ)
-29	-20.2	853.5	23	73.4	53.74	75	167.0	7.224
-28	-18.4	799.8	24	75.2	51.41	76	168.8	6.998
-27	-16.6	750	25	77.0	49.19	77	170.6	6.761
-26	-14.8	703.8	26	78.8	47.08	78	172.4	6.542
-25	-13.0	660.8	27	80.6	45.07	79	174.2	6.331
-24	-11.2	620.8	28	82.4	43.16	80	176.0	6.129
-23	-9.4	580.6	29	84.2	41.34	81	177.8	5.933
-22	-7.6	548.9	30	86.0	39.61	82	179.6	5.746
-21	-5.8	516.6	31	87.8	37.96	83	181.4	5.565
-20	-4.0	486.5	32	89.6	36.38	84	183.2	5.39
-19	-2.2	458.3	33	91.4	34.88	85	185.0	5.22
-18	-0.4	432	34	93.2	33.45	86	186.8	5.06
-17	1.4	407.4	35	95.0	32.09	87	188.6	4.904
-16	3.2	384.5	36	96.8	30.79	88	190.4	4.754
-15	5.0	362.9	37	98.6	29.54	89	192.2	4.609
-14	6.8	342.8	38	100.4	28.36	90	194.0	4.469
-13	8.6	323.9	39	102.2	27.23	91	195.8	4.334
-12	10.4	306.2	40	104.0	26.15	92	197.6	4.204
-11	12.2	289.6	41	105.8	25.11	93	199.4	4.079
-10	14.0	274	42	107.6	24.13	94	201.2	3.958
-9	15.8	259.3	43	109.4	23.19	95	203.0	3.841
-8	17.6	245.6	44	111.2	22.29	96	204.8	3.728
-7	19.4	232.6	45	113.0	21.43	97	206.6	3.619
-6	21.2	220.5	46	114.8	20.6	98	208.4	3.514
-5	23.0	209	47	116.6	19.81	99	210.2	3.413
-4	24.8	198.3	48	118.4	19.06	100	212.0	3.315
-3	26.6	199.1	49	120.2	18.34	101	213.8	3.22
-2	28.4	178.5	50	122.0	17.65	102	215.6	3.129
-1	30.2	169.5	51	123.8	16.99	103	217.4	3.04
0	32.0	161	52	125.6	16.36	104	219.2	2.955
1	33.8	153	53	127.4	15.75	105	221.0	2.872
2	35.6	145.4	54	129.2	15.17	106	222.8	2.792
3	37.4	138.3	55	131.0	14.62	107	224.6	2.715
4	39.2	131.5	56	132.8	14.09	108	226.4	2.64



**Appendix 3: Resistance Table of Outdoor Discharge Temperature Sensor (50K)**

Temp (°C)	Temp (°F)	Resistance (kΩ)		Temp (°C)	Temp (°F)	Resistance (kΩ)		Temp (°C)	Temp (°F)	Resistance (kΩ)
5	41.0	125.1		57	134.6	13.58		109	228.2	2.568
6	42.8	119.1		58	136.4	13.09		110	230.0	2.498
7	44.6	113.4		59	138.2	12.62		111	231.8	2.431
8	46.4	108		60	140.0	12.17		112	233.6	2.365
9	48.2	102.8		61	141.8	11.74		113	235.4	2.302
10	50.0	98		62	143.6	11.32		114	237.2	2.241
11	51.8	93.42		63	145.4	10.93		115	239.0	2.182
12	53.6	89.07		64	147.2	10.54		116	240.8	2.124
13	55.4	84.95		65	149.0	10.18		117	242.6	2.069
14	57.2	81.05		66	150.8	9.827		118	244.4	2.015
15	59.0	77.35		67	152.6	9.489		119	246.2	1.963
16	60.8	73.83		68	154.4	9.165		120	248.0	1.912
17	62.6	70.5		69	156.2	8.854		121	249.8	1.863
18	64.4	67.34		70	158.0	8.555		122	251.6	1.816
19	66.2	64.33		71	159.8	8.268		123	253.4	1.77
20	68.0	61.48		72	161.6	7.991		124	255.2	1.725
21	69.8	58.77		73	163.4	7.726		125	257.0	1.682
22	71.6	56.19		74	165.2	7.47		126	258.8	1.64

